

TECHNICAL OPINION REPORT

SUBMITTED TO CIDB MALAYSIA | SEPTEMBER 2017

PRODUCT
YJACK

APPLICANT

YJACK Technology Sdn. Bhd.



FOREWORD

Construction Industry Development Board (CIDB Malaysia) is a statutory body enacted under the Act 520 in 1994. Its mission is to develop Malaysian Construction Industry towards global competitiveness. To support that mission, a number of functions were formulated and one of them is to encourage the improvement of construction techniques and materials. Under that function, CIDB is to carry out assessment and appraisal of innovations of any kind of product and technology related to construction and to publish its finding, in the form of Technical Opinion.

This Technical Opinion will provide a reference to the relevant / interested parties in the construction industry. CIDB assess innovation based on application and evaluation by its Technical Opinion. Applicants may use it as a supporting document for regulatory and approving authorities, architects, engineers and others in dealing with the new products and technologies.

This Technical Opinion is prepared on behalf of CIDB by The Technical Expert Panel on construction products, construction material and technology in Construction Industry. The Technical Expert Panel was set-up by CIDB and its members are drawn from experts that represent relevant sectors in the construction industry.

This Technical Opinion has been modelled based on international recommended practice.

CIDB Technical Expert Panel Committee for YJACK

Technical Expert Panel

Dr. Foo Chee Hung	(Chairman)	Construction Research Institute of Malaysia (CREAM)
Prof. Dr. Mohd. Raihan Taha	(Technical Expert Panel)	Universiti Kebangsaan Malaysia (UKM)
Ir. Dr Chan Swee Huat	(Technical Expert Panel)	The Institution of Engineers Malaysia (IEM)
Ir. Som Pong Pichan	(Technical Expert Panel)	Jabatan Kerja Raya (JKR)
Dr. HM Abdul Aziz bin KM Hanifah	(Technical Expert Panel)	LR Two Consult Sdn. Bhd.

Secretariat

Natasha Binti Dzulkalnine	Construction Research Institute of Malaysia (CREAM)
---------------------------	---

GENERAL PROVISIONS

The purpose of this report is to assist respective parties, both the applicant and the granting approval authority, to understand issues with regard to the specification and the uses of the product under study. This report shall not be considered as approval.

Special note should be taken of the provisions and limitations set out and the period of validity of the Technical Opinion.

Technical Opinion is initially given a term of validity of three (3) years from the date of issue in the expectation that, after that period, the subject will no longer be an innovation. They can be reviewed within the first twelve (12) months and again as necessary during the life of the products or system described in the document. The limitation on the validity of the opinions should not be interpreted as implying a similarly limited life expectancy of the products or system described in the Technical Opinion. However, if experience shows poor overall standard of quality or performance, the Technical Opinion will be withdrawn.

The legitimacy and validity of the Technical Opinion can be verified at the CIDB Head Office.

CIDB and the Technical Expert Panel shall accept no responsibility for the quality and performance of the products.

This document must not be duplicated in any form without permission from CIDB.

Disclaimer

While every effort is made to ensure accuracy of the information presented in this report, neither the Technical Expert Panel nor its Secretariats or CIDB can accept responsibility for any loss or damage incurred in connection with the use of the contents.

Definition

Technical Opinion Programme	A programme initiated by CIDB with the aim to evaluate products, materials, components or system with regard to, but not limited to IBS. It normally covers wide range of innovative products to be used in local construction industry
Technical Expert Panel	Individuals are selected based on their expertise in geotechnical engineering
YJACK	YJACK is a type of flat jack for use in bi-directional pile load test

Abbreviation

API	Application Programming Interface
BD	Bi-directional
CIDB	Construction Industry Development Board
CREAM	Construction Research Institute of Malaysia
FEM	Finite Element Modelling
IBS	Industrialised Building System
ICP	Industrial Concrete Products Sdn Bhd
IEM	The Institution of Engineers Malaysia
JKR	Jabatan Kerja Raya
Mc	Crack Moment
MLT	Maintained Load Test
MS	Malaysian Standard
P _c	Equivalent Crack Load
P _{max}	Ultimate Load
QA	Quality Assurance
QC	Quality Control
QLT	Quick Load Test
SC	Spun Concrete
SL	Static Load
UKM	Universiti Kebangsaan Malaysia

Symbols

kN	kilonewton
kNm	kilonewton metre
MPa	megapascal
tn	ton
cm	centimetre
mm	millimetre
m	metre
%	percentage
Ø	diameter
≥	greater than or equal to
≤	less than or equal to

List of Table

Table 2.1	Comparison of YJACK Technology with other BD Pile Tests	7
Table 2.2	Types of YJACK	8
Table 3.1	List of YJACK bi-directional bored pile tests	10
Table 3.2	List of YJACK bi-directional concrete pile tests	12
Table 5.1	Compression test criteria	13
Table 5.2	Bending test criteria	13
Table 5.3	Test Results for Ultimate Compression Load for Pile Body and YJACK Connector	14
Table 5.4	Test Results for Ultimate Bending Load for Pile Body and YJACK Connector	14
Table 5.5	Static study analysis for 300mm YJACK	14
Table 5.6	Static study analysis for 400mm YJACK	14

List of Figure

Figure 2.1:	YJACK components	7
Figure 2.2:	YJACK type C installation process	10
Figure 5.1	YJACK bidirectional pile test result – FG-19(5)	15
Figure 5.2	YJACK bidirectional pile test result – G-21(5)	15
Figure 5.3	Comparison between MLT result and interpreted YJACK test result – FG-19(5)	16
Figure 5.4	Comparison between MLT result and interpreted YJACK test result – G-21(5)	16
Figure 5.5	YJACK bidirectional test result – TOP1A	17
Figure 5.6	YJACK bidirectional test result – TOP1B	17
Figure 5.7	YJACK bidirectional test result – TOP2A	18
Figure 5.8	YJACK bidirectional test result – TOP2B	18
Figure 5.9	Comparison between MLT result and interpreted YJACK test result – TOP1A	19
Figure 5.10	Comparison between MLT result and interpreted YJACK test result – TOP1B	19
Figure 5.11	Comparison between MLT result and interpreted YJACK test result – TOP2A	20
Figure 5.12	Comparison between MLT result and interpreted YJACK test result – TOP2B	20

CONTENT	PAGE
1.0 IDENTIFICATION	
1.1 Name of Product	6
1.2 Country of Origin	6
1.3 Dates of Evaluation	6
1.4 Purpose	6
1.5 Applicant & Address	6
2.0 DESCRIPTIONS	
2.1 General Descriptions of Project	6
2.2 Element of Product	7
2.3 Usage Application	10
3.0 LIST OF BI-DIRECTIONAL PILE LOAD TEST	
3.1 Bored Pile Test	10
3.2 Concrete Pile Test	12
4.0 BASIS OF APPRAISAL	
4.1 Document Received from the Applicant	12
5.0 STANDARDS, SPECIFICATIONS AND TESTS	
5.1 Compression and Bending Tests	13
5.2 Finite Element Modelling	14
5.3 Validation Test of YJACK Bi-directional Pile Load Test – A Case Study in Kangsar	15
5.4 Validation Test of YJACK Bi-directional Pile Load Test – A Case Study in Muar	17
6.0 QUALITY ASSURANCE / QUALITY CONTROL	
6.1 QA / QC Plan	21
7.0 VALIDITY OF OPINION	
7.1 Condition	21
7.2 Recommendations from Technical Expert Panel	21
7.3 Withdrawal	21
7.4 Term of Validity	21
8.0 APPROVED OPINION ABSTRACT	22
9.0 APPENDICES	

1.0 IDENTIFICATION

1.1 Name of Product

YJACK

1.2 Country of Origin

Malaysia

1.3 Dates of Evaluation

22nd September 2014 : First meeting of Technical Expert Panel
8th March 2016 : Second meeting of Technical Expert Panel
14th March 2017 : Third meeting of Technical Expert Panel

1.4 Purpose

YJACK is a patented jack designed for bi-directional (BD) static pile load test on driven piles (Patent #: PI2014000539). Professional YJACK adopts bladder sealing technology (Patent #: CN201694784U).

1.5 Applicant & Address

YJACK Technology Sdn. Bhd.
Level 16, 1 Sentral,
KL Sentral,
50470, Kuala Lumpur

Contact	Telephone	:	03-20929274
	Fax	:	03-20929201
	Hand Phone	:	012-3259090
	Contact Person	:	Mr. Yeow Leong Swee

2.0 DESCRIPTION

2.1 General Description of Product

YJACK is a pile test instrument to carry out static pile load testing using bi-directional (BD) test method. It is an alternative method to the conventional maintained load test using Kentledge blocks or reaction piles methods.

2.2 Elements of Product

2.2.1 Components

YJACK comprises of two main components: the cylinder shell (in red colour) and piston shell (in grey colour) (Figure 2.1). It is a press jack that the pressure load is applied by using hydraulic capsule unit instead of piston hydraulic jack. YJACK is connected in spliced joint (between two pile sections) which will be installed by pile driving hammer like a normal driving pile into the ground.



Figure 2.1: YJACK components

2.2.2 Technology

The core technology of YJACK adopts a flat jack (or multiple jacks) to conduct BD pile tests on all pile types such as driven/jack-in close-ended reinforced concrete piles, open-ended and offshore piles, as well as cast in-situ micro-API and bored piles.

Table 2.1 shows the comparison of YJACK technology with other BD pile tests.

Table 2.1: Comparison of YJACK Technology with other BD Pile Tests

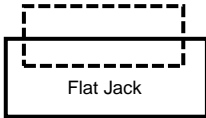
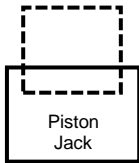
Comparisons	YJACK Technology	Other Technology
Technology	Flat Jack using bladder seal technology	Piston Jack using oil seal technology
Jack Designs		
Jack Applications	Since 2006: <ul style="list-style-type: none"> • Cast in-situ drilled piles After 2014 with world's patents: <ul style="list-style-type: none"> • Drive / jack-in close-ended piles • Drive / jack-in close-ended piles • Cast in-situ API-micro piles 	Since 1980s: <ul style="list-style-type: none"> • Cast in-situ drilled piles
Jack Fabrications for	Conical blocks attached at the top and bottom of the jacks. The sediments will	Steel plates attached at the top and bottom of the jacks. The sediments will

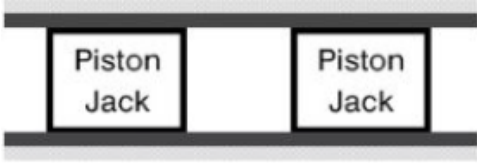
<p>drilled piles</p>	<p>not be stuck at the top of the jack. Solid concrete formed.</p>  <p>Bottom conical shape to allow the concrete to flow easily from bottom to top. No sediments block at bottom.</p>	<p>be stuck at the top of the steel plate. Soft concrete formed.</p>  <p>Bottom steel plate with flat shape will block concrete and sediments to flow. Soft concrete formed.</p>
----------------------	---	--

2.2.3 Types of YJACK

There are four types of YJACK: C, O, B, and M, which are applied to closed ended piles, open ended piles, API micro piles, and bored piles, respectively. Table 2.2 describes the characteristics of each of these YJACK:

Table 2.2: Types of YJACK

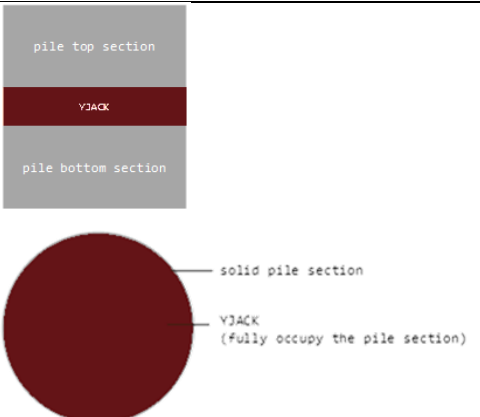
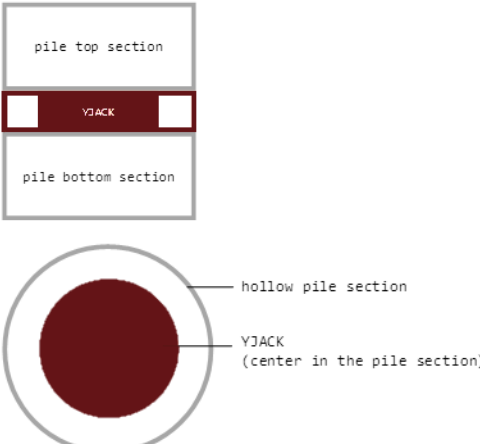
Type	Description	Illustration
<p>Type C</p>	<p>This type of YJACK is designed for close-ended piles such as reinforced concrete, spun concrete and steel pipe piles with pile shoes. The steel H-pile is classified as close-ended piles.</p>	
<p>Type O</p>	<p>This type of YJACK is designed for open ended piles such as spun concrete and steel pipe piles without pile shoes, as well as offshore open-ended piles.</p> <p>The major difference of YJACK Type O compared to Type C is that Type O allows soil to move past through the YJACK location during pile driving. The physical design of Type O and C is similar.</p>	

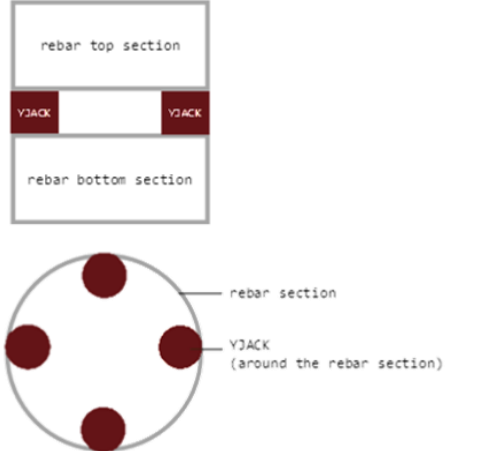
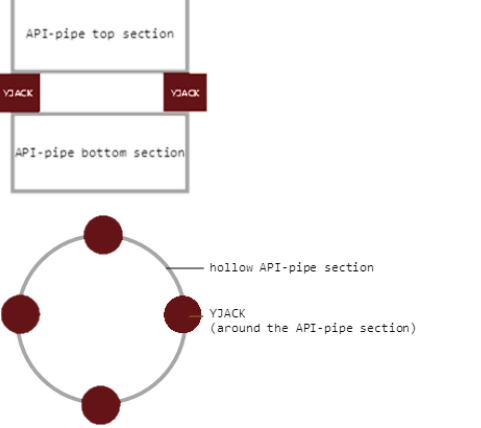
<p>Type B</p>	<p>The major difference of YJACK compared to ojack (o-cell or o-jack) is the jack design, YJACK uses flat jack technology, whereas ojack uses piston jack.</p>	 <p>The diagram for Type B YJACK consists of two parts. The top part is a rectangular cross-section showing a 'rebar top section' and a 'rebar bottom section' connected by two 'YJACK' components. The bottom part is a circular cross-section showing a 'rebar section' and 'YJACK (around the rebar section)' components arranged around the perimeter of the circle.</p>
<p>Type M</p>	<p>This type of YJACK is specifically designed for micro piles with API as the structural element of the piles.</p>	 <p>The diagram for Type M YJACK consists of two parts. The top part is a rectangular cross-section showing an 'API-pipe top section' and an 'API-pipe bottom section' connected by two 'YJACK' components. The bottom part is a circular cross-section showing a 'hollow API-pipe section' and 'YJACK (around the API-pipe section)' components arranged around the perimeter of the circle.</p>

2.2.4 Installation Process

YJACK is installed by pile driving hammer like a normal driving pile into the ground. The installation process is as follows:

- i. Splice the YJACK at the end bearing (i.e. 0m from pile toe);
- ii. Pile positioning, check verticality and then continue driving;
- iii. Hydraulic hoses and telltales are attached and fixed along the pile body; and
- iv. End of pile driving and completion of the YJACK installation.

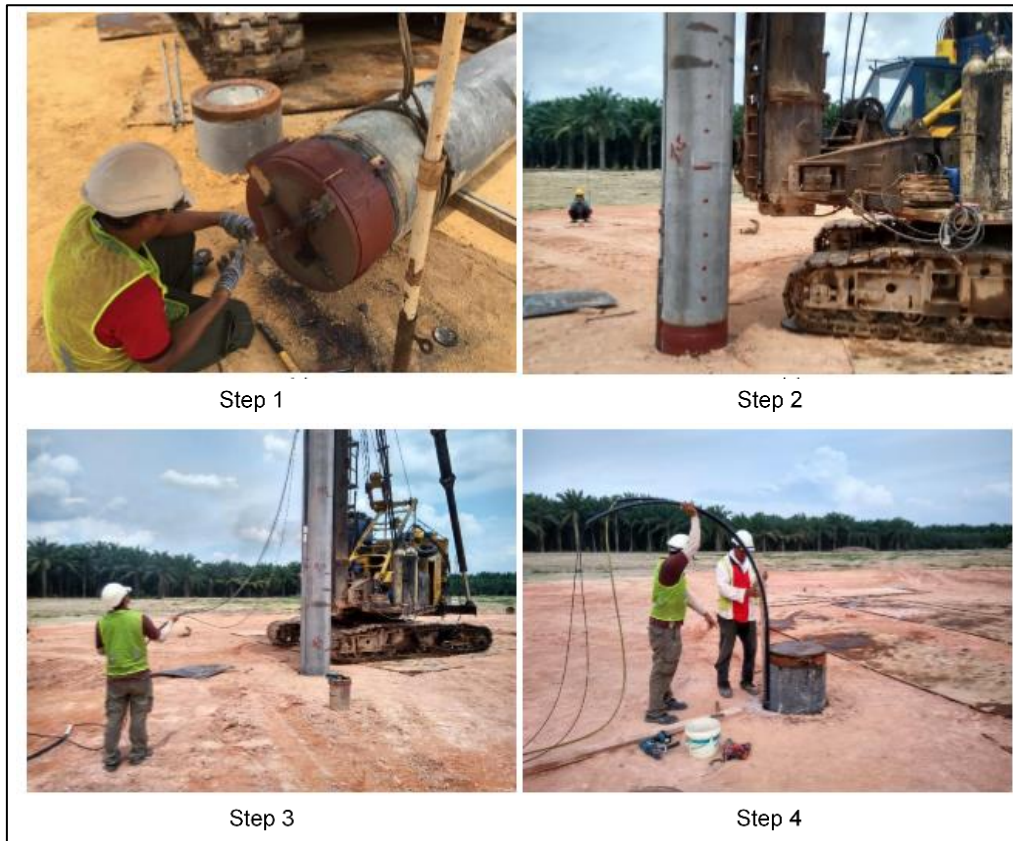

Figure 2.2: YJACK type C installation process

2.3 Usage Application

YJACK is a patented innovation to carry out bi-directional (BD) pile test in static load (SL) pile bearing testing. It is an alternative method to conventional maintained load test using kentledge blocks or reaction piles methods.

3.0 LIST OF BI-DIRECTIONAL PILE LOAD TEST

3.1 Bored Pile Test

Table 3.1 shows the list of YJACK bi-directional bored pile tests.

Table 3.1: List of YJACK bi-directional bored pile tests

Date	Contractor/Piling	Project Title/Site/Scope of Work	Tonnage
9 th April 2015	Khiap Hup Construction & Engineering Sdn Bhd	Membina Jambatan Konkrit Menyeberangi Sungai Jelai Di Kampung Gemunchor, Mukim Cheka 1, Lipis, Pahang DM (bored piles design/ testing near Jerantut-Lipis)	490
1 st April 2016	Geospec Piletech Sdn Bhd	Cadangan Pembinaan Jalan dan Jambatan Menghubungi Kawasa Antara Bangunan Maybank dan Kawasan Ming Court Garden Si Sembulan, Kota Kinabalu, Sabah.	600
26 th April 2016	Econpile (M) Sdn Bhd	Spice-Piling and Basement Works to Hotel, Jalan Tun Dr. Awang, Mukim 12, Daerah Barat Daya, Pulau Pinang.	3,030

7 th May 2016	Top Down Construction Sdn Bhd	Pembinaan Jalan Utama Jaringan Jalan dalam Kampus dan Kerja-Kerja Infrastruktur di Universiti Malaysia Kelantan, Kampus Jeli.	1,600
16 th August 2016	Geospec Piletech Sdn Bhd	New Sarawak Museum and Annex Building, Section 31, Kuching Town Land District at Jln Tun Abang Haji Openg, Sarawak.	2,800
15 th September 2016	Geospec Piletech Sdn Bhd	Proposed Commercial Cum Residential Development & Transport Hub at Tanjung Aru, Kota Kinabalu, Sabah. Flyover with Road Widening Works at Chainage 0+84m Jalan Kepayan & On Road Reserves.	2,820
26 th November 2016	AP-COL Geotechnics Sdn Bhd	KK Metro Town (Hotel and Shopping), Off Jalan TUaran, Kota Kinabalu, Sabah.	3,300
30 th November 2016	Sunway Geotechnics (M) Sdn Bhd	Proposed RC8 Condominium for Sunway College, Bandar Sunway.	2,000
5 th December 2016	Pintaras Geotechnics Sdn Bhd	38 Storey Pinnacle Condo at Kuala Lumpur, for bored piles diameter BP1200mm and BP2400mm for YJACK test load YJ2000tn and YJ8000tn respectively.	10,000
10 th March 2017	PC Geotechnics Sdn Bhd (Peck Chew Piling)	Proposed Design and Build, Testing and Commissioning of Extension and Refurbishment Works to the Existing Shopping Complex Compete with Infrastructure Works to Aeon Maluri Shopping Centre, Malan Jejaka, Taman Maluri, Cheras, 55100, Kuala Lumpur.	2,340
Letter Award	Geospec Piletech Sdn Bhd	Proposed Subdivision for 10 storey Town & Regional Planning Department Headquarters Block at Jalan Tasik, District of Kinabalu, Sabah.	600
Letter Award	Musyati Sdn Bhd (Geospec Piletech Sdn Bhd)	Proposed Pan Borneo Highway, Package WPC 08 – Batang Mukah Load Test, Sarawak.	3,120
16 th March 2017	AP-COL Geotechnics Sdn Bhd	KK Metro Town (Hotel and Shopping), Off Jalan Tuaran, Kota Kinabalu, Sabah.	1,700
10 th April 2017	PC Geotechnics Sdn Bhd (Peck Chew Piling)	AEON Maluri Shopping Mall Extension, Taman Maluri, Kuala Lumpur.	1,560
14 th April 2017	Top Down Construction Sdn Bhd	Cadangan Tebatan Banjir Lembangan Sungai Muar Johor. Pembinaan Pintasan Belemang di Sungai Muar dan Kerja-Kerja Berkaitan.	1,700
22 nd April 2017	ChengalJati Sdn Bhd	Bi-Directional Test with Pile Instrumentation at SUKE – Pakej CA1	5,400
28 th April 2017	Kelpile Geotechnics Sdn Bhd	Verdepalm Project Malaysia, Johor (Bio-Xcell Technical Park at Nusajaya)	2,000
8 th April 2017	TBT Piling (Sabah) Sdn Bhd	Proposed Development of 3 Block of 16-storey Condominium (768-units) with Roof Top Sky Lounge, Jalan Bundusan, District of Penampang (Triconic Tower)	1,500
Letter Award	Geospec Piletech Sdn Bhd	Multi-Storey Mixed-Use Commercial Cum Hotel Development at Jalan Nenas, Kota Kinabalu, Sabah.	5,000
30 th April 2017	Khiap Hup Resources Sdn Bhd	Bi-Directional Test at Jambatan Gua Musang, Kelantan.	5,000
5 th May 2017	Dong Yue Construction Sdn Bhd (bored piles)	Forest City Landmark Tower, Forest City, Mukim Tanjung Kupang, Daerah Johor Bahru, Johor Darul Takzim.	22,600
22 nd June 2017	Techright Resources Sdn Bhd	Proposed Expressway from Putrajaya to KLIA (MEX 2).	20,000
23 rd June 2017	Geospec Piletech Sdn Bhd	Proposed Pan Borneo Highway, Package WPC 08 – Batang Tatau Load Test, Sarawak.	3,880

3.2 Concrete Pile Test

Table 3.2 shows the list of YJACK bi-directional concrete pile tests.

Table 3.2: List of YJACK bi-directional concrete pile tests

Date	Contractor/Piling	Project/Site	Tonnage
7 th January 2014	YJACK Technology Sdn Bhd	YJACK Pilot Test at Kota Kinabalu, Sabah (the first YJACK in the world on driven pile)	320
9 th December 2014	YJACK Technology Sdn Bhd	Proposed Sekolah Rendah Agama (SRA) Pantai Dalam, Kuala Lumpur, Wilayah Persekutuan.	100
6 th February 2015	Sichuan Construction Sdn Bhd	88 Unit Teras Vila Riadah 2 Tingkat Di Atas Blok 1, Lot 227, Pekan Pasir Bogak, Pulau Pangkor, Daerah Manjung, Negeri Perak Darul Ridzuan.	40
7 th February 2015	Sichuan Construction Sdn Bhd	1 Blok Hotel Pelancongan 4 Tingkat di Atas Blok 4, Lot 227, Pekan Pasir Bogak, Pulau Pangkor, Daerah Manjung, Negeri Perak Darul Rizuan.	160
21 st December 2015	Aliah Enterprise	Carry out Bi-Directional Pile Load Test by Using YJACK Method at Muar, Johor.	240
20 th December 2015	Cylonix Geotechnics Sdn Bhd	Carry out Bi-Directional Pile Load Test by Using YJACK Method at Bahau, Negeri Sembilan.	650
18 th January 2016	Cylonix Geotechnics Sdn Bhd	Carry Our Bi-Directional Pile Load Test by using YJACK Method at Hulu Langat in Klang Valley	200
15 th February 2016	Cylonix Geotechnics Sdn Bhd	Carry out Bi-Directional Pile Load Test by using YJACK Method at Gombak in Selangor	180
10 th March 2016	Cylonix Geotechnics Sdn Bhd	DBKL Missing Road Bukit Jalil, Jalan Jalil Perkasa 7 ke Jalan Barat, Bukit Jalil, Kuala Lumpur.	1,840
30 th March 2016	Cylonix Geotechnics Sdn Bhd	Carry out Bi-Directional Pile Load Test by Using YJACK Method at Bangi Heights in Kajang.	400
8 th April 2016	WZS KenKeong Sdn Bhd	Privitisation of Lebuhraya Persisiran Pantai Barat (Taiping – Banting) Section 9 – Kg. Lekir to Changkat Cermin Interchange, Perak.	10,350
28 th June 2016	Geospec Piletech Sdn Bhd	Pembinaan Jabatan Sg. Sawit, Betong, Sarawak.	160
11 th July 2016	Cylonix Geotechnics Sdn Bhd	Carry out Bi-Directional Pile Load Test by using YJACK Method at Kangsar, Perak.	300
25 th August 2016	Cylonix Geotechnics Sdn Bhd	Villaku, Pulau Pangkor, Daerah Manjung, Negeri Perak Darul Rizuan.	260
12 th October 2016	Wangsatama Sdn Bhd	Pembinaan Semula Kwarters Kakitangan Jabatan Kebajikan Masyarakat (JKM) di Taman Sinar Harapan Tampoi, Johor Bahru.	520
8 th November 2016	Pembinaan Jemerlang Sdn Bhd	Proposed Pulau Indah Elevated Highway, Pulau Indah, Selangor.	800
12 th January 2017	Billion Engineering Sdn Bhd	Cadangan Membina dan Menyiapkan Dua, Block Empat Tingkat Bangunan Sra Ehyaul Falah 2, Sungai Besar Serta Kerja-Kerja Berkaitan, Daerah Bernam Selangor Darul Ehsan.	280
28 th April 2017	Kelpile Geotechnics Sdn Bhd	Verdepalm Project Malaysia, Johor (Bio-Excell Technical Park at Nusajaya).	2,000
Letter of Intend	Dong Yue Construction Sdn Bhd	Corest City Landmark Tower, Forest City, Mukim Tanjung Kupang, Daerah Johor Bahru, Johor Darul Takzim.	5,800

4.0 BASIS OF APPRAISAL

4.1 Document Received from the Applicant

The following documents were received from YJACK Technology Sdn. Bhd. For product evaluation by the Technical Expert Panel:

- i. Product Brochure (see Appendix A, YJACK Technology Sdn. Bhd.);
- ii. Structural Laboratory Tests Report (see Appendix B, YJACK Technology Sdn. Bhd.);
- iii. Finite Element Modelling (FEM) Analysis Report (see Appendix C, YJACK Technology Sdn. Bhd.);
- iv. Validation Test of YJACK Bi-directional Pile Load Test – A Case Study at Kangsar (see Appendix D, YJACK Technology Sdn. Bhd.); and
- v. Validation Test of YJACK Bi-directional Pile Load Test – A Case Study at Muar (see Appendix E, YJACK Technology Sdn. Bhd.).

5.0 STANDARDS, SPECIFICATIONS AND TESTS

5.1 Compression and Bending Tests

Compression and bending tests were conducted based on the following standards:

- i. Malaysian Standard for Precast Concrete Piles: MS/1314 (2004)
- ii. JKR Standard Specifications for Building Works: JKR/20800-0183 (2014)

under the test criteria as shown in Table 5.1 and Table 5.2 (see Appendix B):

Table 5.1: Compression test criteria

ICP SC Grade 80, Class B Pile Body*	Axial Working Load (kN)	Ultimate Compression Load (kN)
Spun Concrete SC300Ø	844 (= 86tn)	1,688 (= 2 x Working Load)
Spun Concrete SC400Ø	1,501 (=153tn)	3,002 (= 2 x Working Load)

*Manufactured by Industries Concrete Products (ICP), Spun Concrete, Grade 80, Class B

Table 5.2: Bending test criteria

ICP SC Grade 80, Class B Pile Body*	Crack Moment, M_c (kNm)	Equivalent Crack Load, P_c (kN)
Spun Concrete SC300Ø	23	34 (use L = 6m specimen)
Spun Concrete SC400Ø	54	80 (use L = 6m specimen)

*Manufactured by Industries Concrete Products (ICP), Spun Concrete, Grade 80, Class B

The results of both the compression and bending tests are as shown in Table 5.3 and Table 5.4, respectively (see Appendix B):

Table 5.3: Test Results for Ultimate Compression Load for Pile Body and YJACK Connector

Specimens	Technical Data Published by ICP Piles	Experimental Test Results
	Ultimate Compression Load (kN)	Ultimate Compression Load (kN)
SC300Ø (Spun Pile Body)	1,688	1,588*
YJ300Ø (YJACK Connector)	N/A	1,750 (3.7%)
SC400Ø (Spun Pile Body)	3,002	Not tested due to lab limitations (performed by FEM analysis)
YJ400Ø (YJACK Connector)	N/A	

*The test result is slightly lower than the technical data published in the catalogue

() The values in the bracket denote the variances of the experimental results

Table 5.4: Test Results for Ultimate Bending Load for Pile Body and YJACK Connector

Specimens	Technical Data Published by ICP Piles			Experimental Test Results	
	Crack Moment, M_c (kN)	Equivalent Crack Load, P_c (kN)	Ultimate Load, P_{max} (kN)	Crack Load, P_c (kN)	Ultimate Load, P_{max} (kN)
SC300Ø (Spun Pile Body)	23	34	61	41	77
YJ300Ø (YJACK Connector)	N/A	N/A	N/A	64 (88%)	81 (33%)
SC400Ø (Spun Pile Body)	54	80	140	107	172
YJ400Ø (YJACK Connector)	N/A	N/A	N/A	116 (45%)	181% (29%)

() The values in the bracket denote the variances of the experimental results

5.2 Finite Element Modelling

The finite element modelling (FEM) analysis was carried out to examine the functionality and durability of YJACK 300 and YJACK 400 in resisting pile compression and bending during pile driving, as to comprehend compression tests which were not able to be conducted in the laboratory due to the limited loading capacity.

The results of the FEM analysis were shown in Table 5.5 and Table 5.6, for both YJACK 300mm and 400mm, respectively (see Appendix C).

Table 5.5: Static study analysis for 300mm YJACK

Force (kN)	0	200	400	600	800	1000	1200	1400	1600	1750
Displacement (cm)	0	0.0038	0.0075	0.0113	0.0150	0.0188	0.0225	0.0263	0.0301	0.0329
Stress (MPa)	0	44.9	89.9	134.8	179.8	224.7	269.6	314.6	359.5	393.2
Minimum Factor of Safety	0	7.82	3.91	2.61	1.96	1.56	1.3	1.12	0.98	0.89

Table 5.6: Static study analysis for 400mm YJACK

Force (kN)	0	250	500	750	1000	1250	1500	1750
Displacement (cm)	0	0.009	0.018	0.027	0.036	0.044	0.053	0.062
Stress (MPa)	0	60.6	121.2	181.8	242.3	302.9	363.5	424.1
Minimum Factor of Safety	0	5.8	2.9	1.93	1.45	1.16	0.97	0.83

5.3 Validation Test of YJACK Bi-directional Pile Load Test – A Case Study in Kangsar

Two YJACK validation correlation tests were performed at a project site in Kangsar, from 2nd to 8th June 2016.

5.3.1 YJACK Test Result

YJACK test results measured at site are shown in Figure 5.1 and Figure 5.2 (see Appendix D):

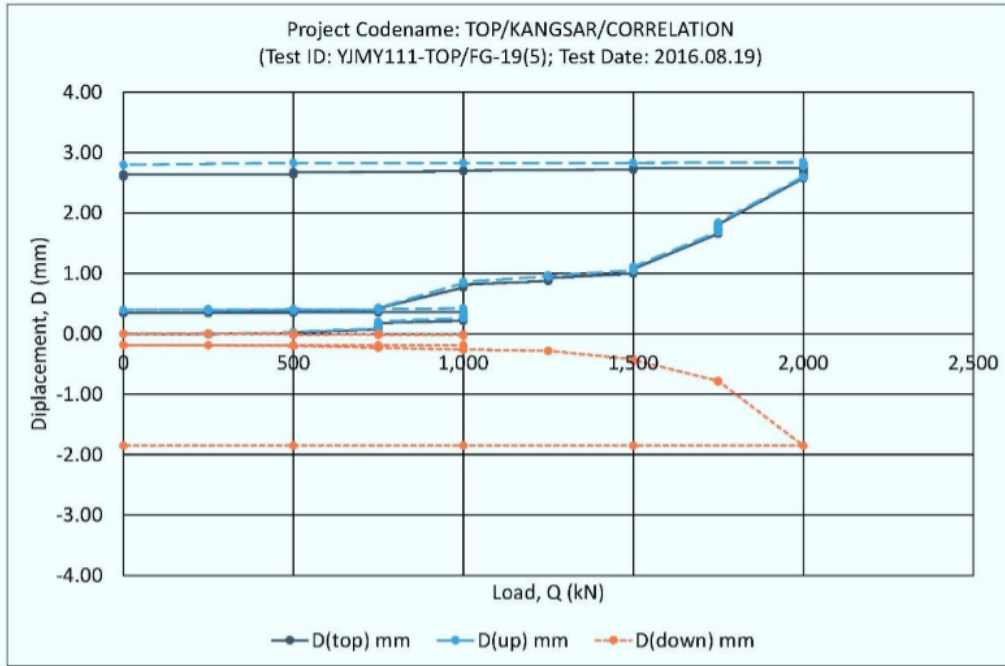

Figure 5.1: YJACK bidirectional pile test result – FG-19(5)

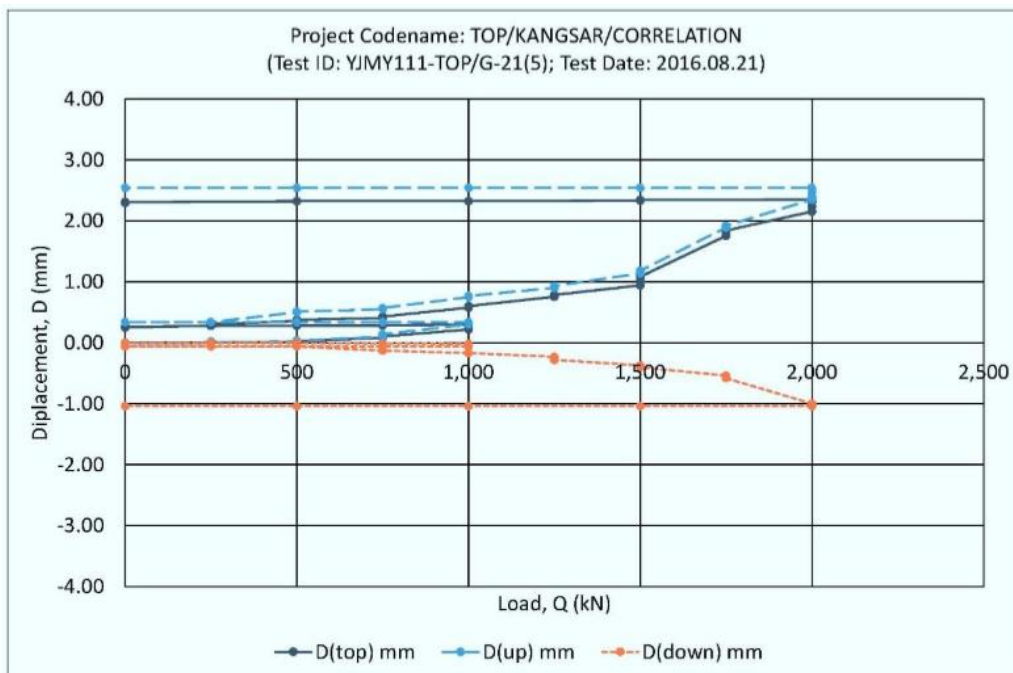

Figure 5.2: YJACK bidirectional pile test result – G-21(5)

5.3.2 Comparison with MLT Result

For comparison purpose, MLTs using kentledge were carried out after the YJACK tests. The comparisons between the MLT and interpreted YJACK test results are shown in Figure 5.3 and Figure 5.4. To note, the conversion of YJACK test results from Section 5.3.1 to Section 5.3.2 is not demonstrated and detailed in the validation report submitted by the Applicant.

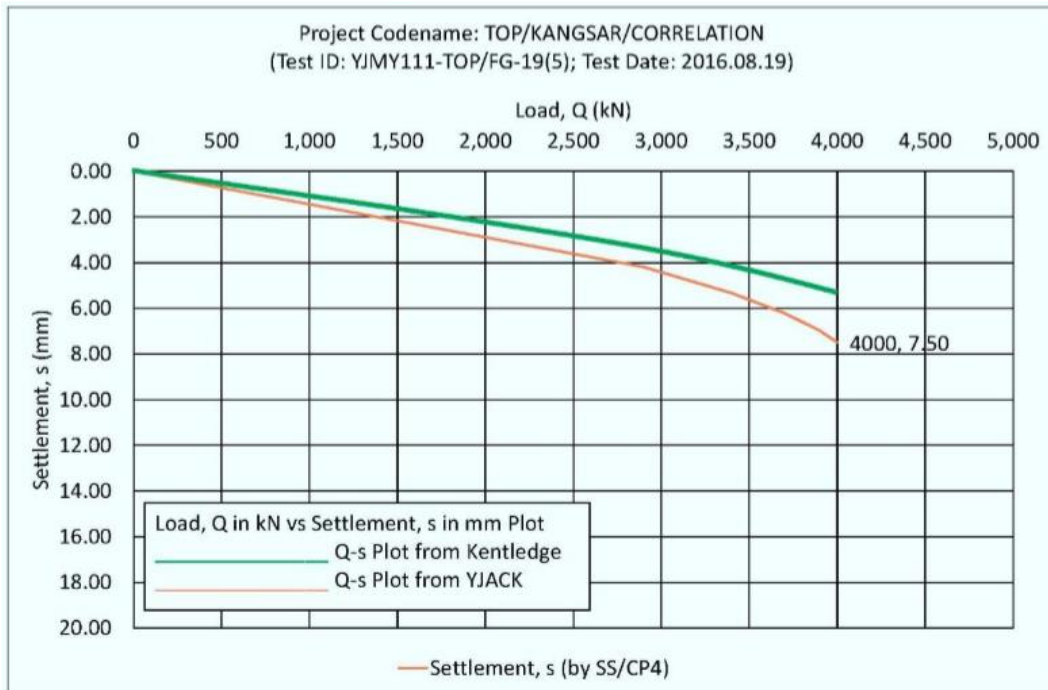

Figure 5.3: Comparison between MLT result and interpreted YJACK test result – FG-19(5)

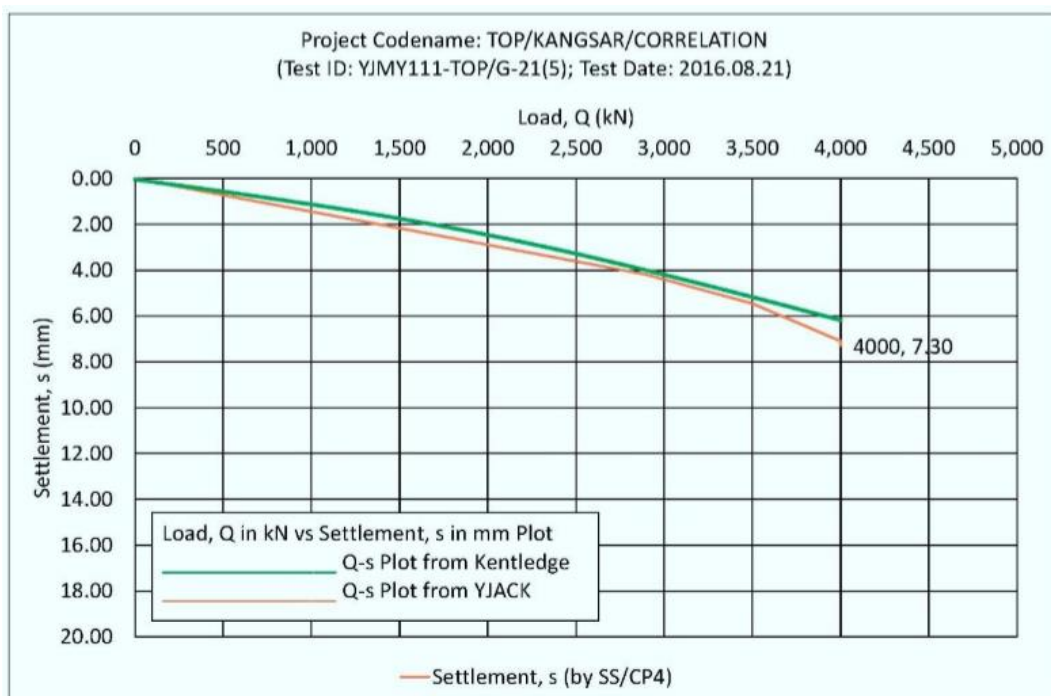

Figure 5.4: Comparison between MLT result and interpreted YJACK test result – G-21(5)

5.4 Validation Test of YJACK Bi-directional Pile Load Test – A Case Study in Muar

Four YJACK validation correlation tests were performed at a project site in Muar, from 10th to 12th October 2015.

5.4.1 YJACK Test Result

YJACK test results measured at site are shown in Figure 5.5 to Figure 5.8 (see Appendix E):

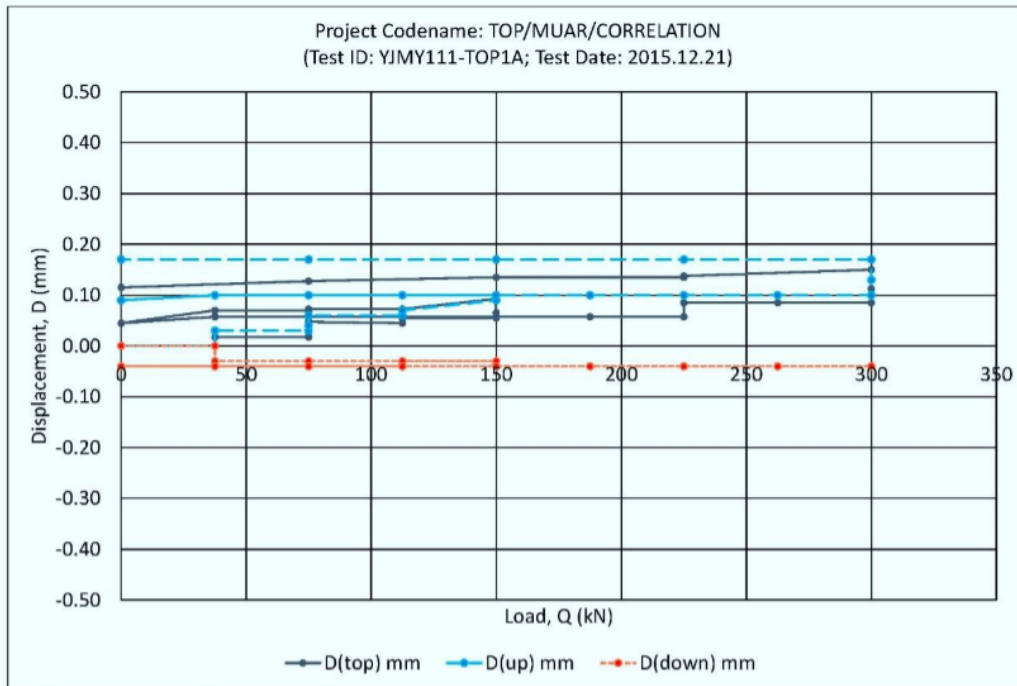

Figure 5.5: YJACK bidirectional test result – TOP1A

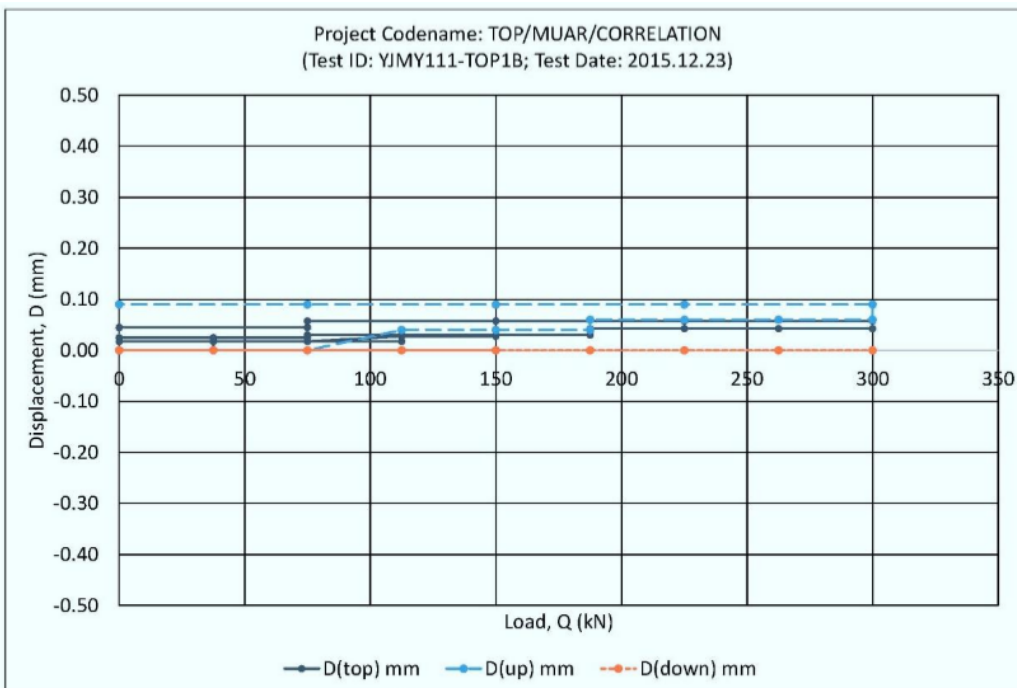

Figure 5.6: YJACK bidirectional test result – TOP1B

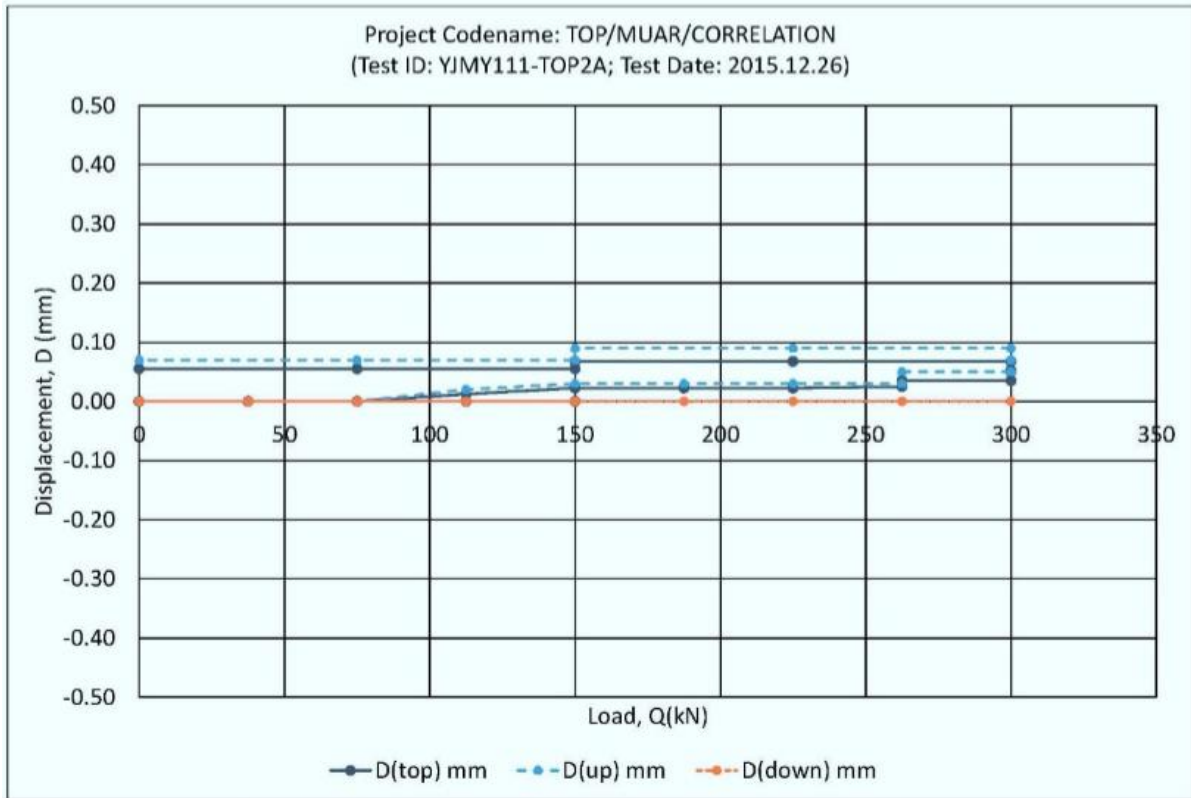

Figure 5.7: YJACK bidirectional test result – TOP2A

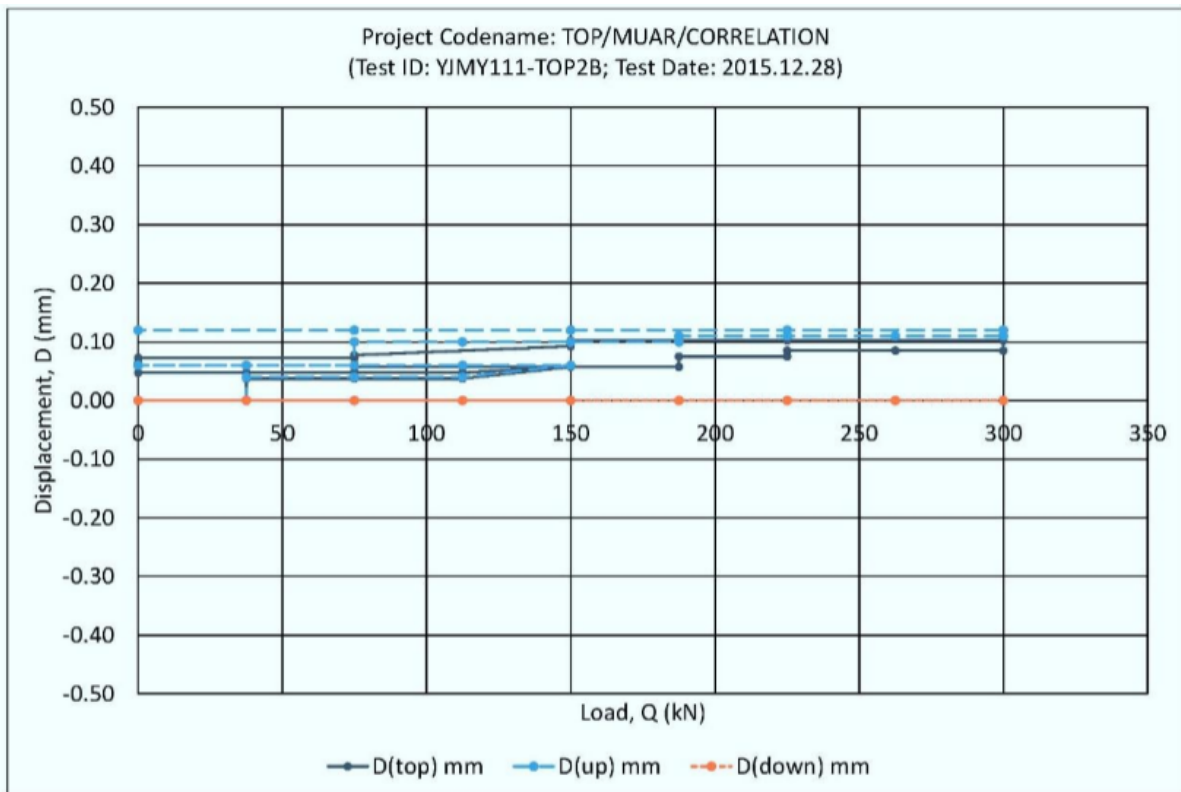

Figure 5.8: YJACK bidirectional test result – TOP2B

5.4.2 Comparison with MLT Result

For comparison purpose, MLTs using kentledge were carried out after the YJACK tests. The comparisons between the MLT and interpreted YJACK test results are shown in Figure 5.9 to Figure 5.12. To note, the conversion of YJACK test results from Section 5.4.1 to Section 5.4.2 is not demonstrated and detailed in the validation report submitted by the Applicant.

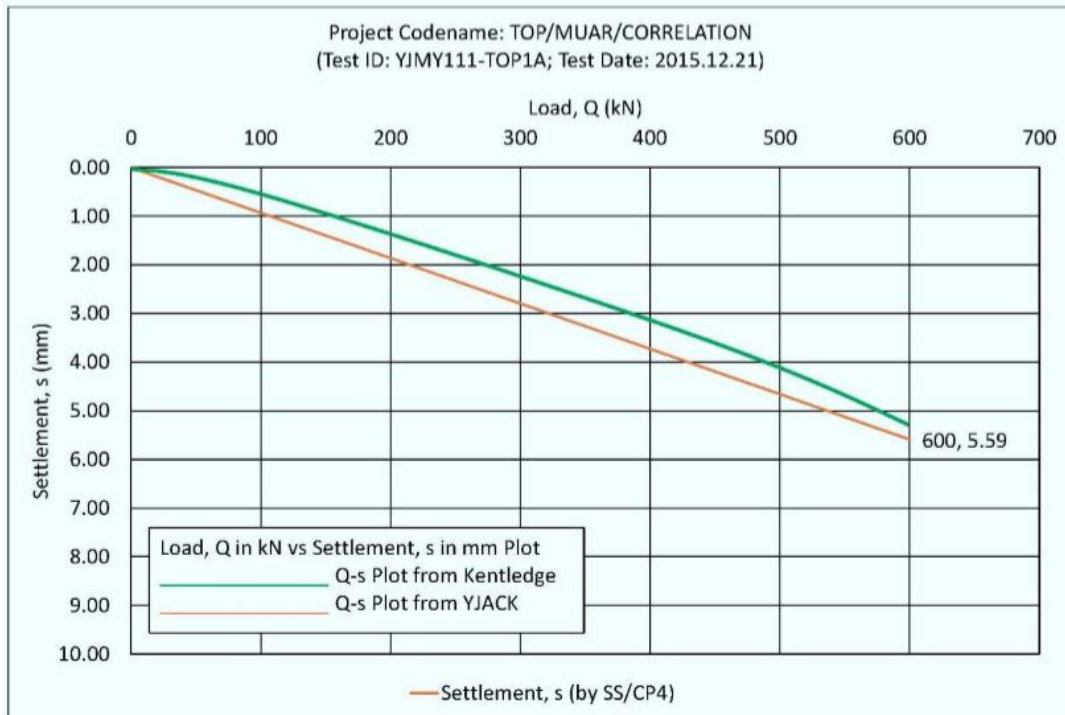

Figure 5.9: Comparison between MLT result and interpreted YJACK test result – TOP1A

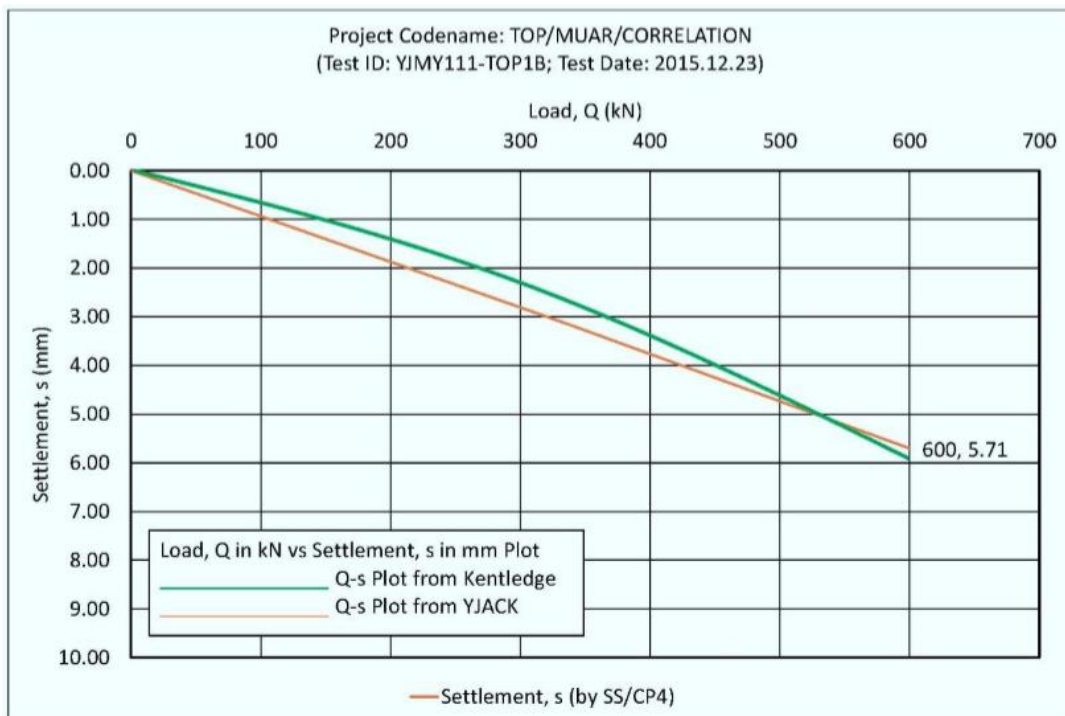

Figure 5.10: Comparison between MLT result and interpreted YJACK test result – TOP1B

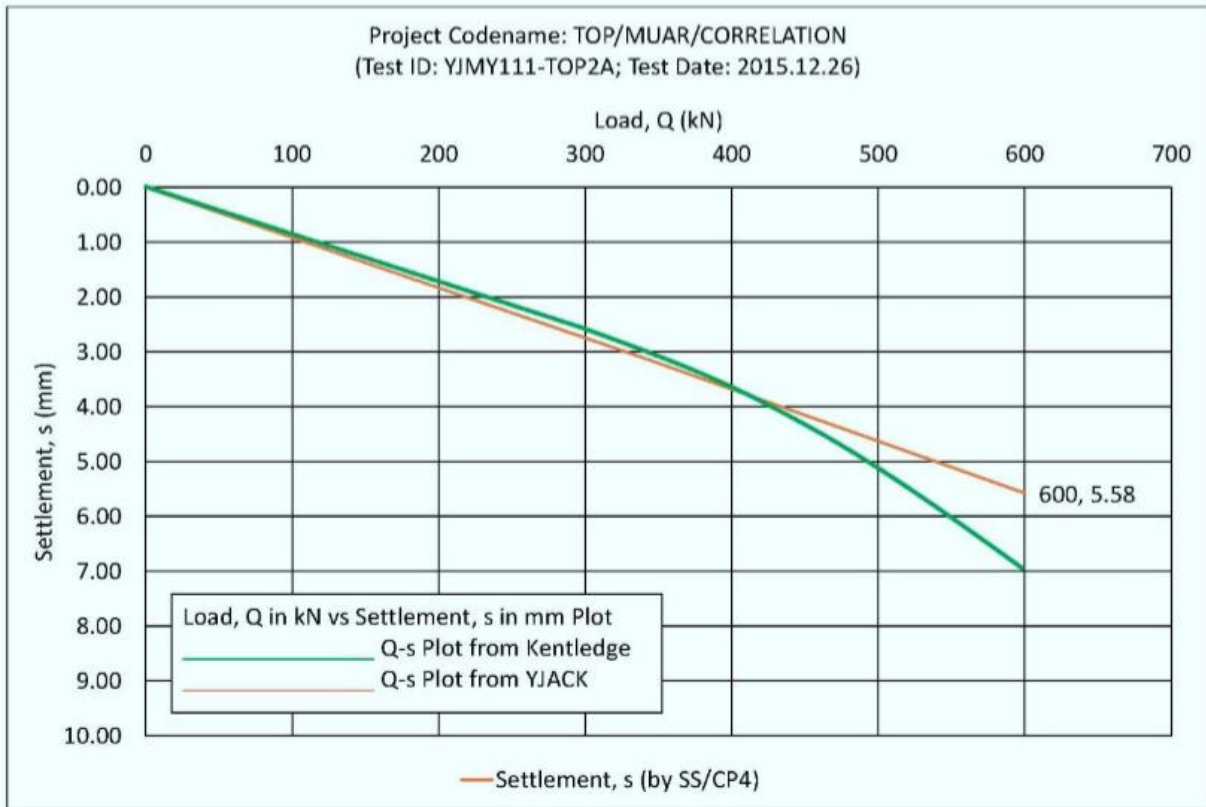

Figure 5.11: Comparison between MLT result and interpreted YJACK test result – TOP2A

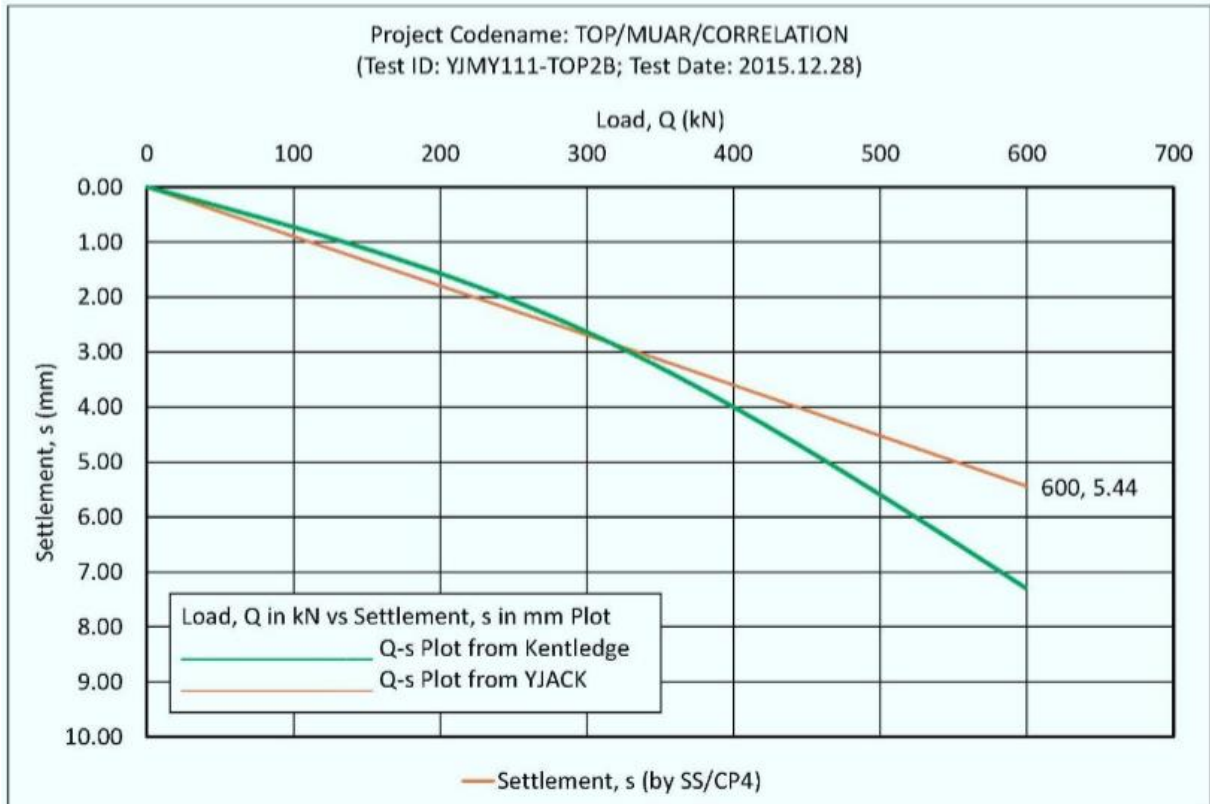

Figure 5.12: Comparison between MLT result and interpreted YJACK test result – TOP2B

6.0 QUALITY ASSURANCE / QUALITY CONTROL

6.1 QA/QC Plan

The information on QA/QC is not available at the time of writing this report. Users may contact the Applicant for further details on QA/QC.

7.0 VALIDITY OF OPINION

7.1 Condition

The Technical Opinion Report given herein is based on several rounds of discussion with the Applicant together with documents and product information made available by the Applicant to the Technical Expert Panel.

This Technical Opinion report is valid for the product specification submitted for evaluation by YJACK Technology Sdn. Bhd. It is the responsibility of the Applicant to notify CIDB of any changes in the product specification mentioned in this report.

7.2 Recommendations from Technical Expert Panel

In the opinion of the Technical Expert Panel, the product has a potential to be used in the local construction industry. However, more justifications are required for the validation test report submitted by the Applicant.

i. The procedures in taking measurements. The reader shall refer to Addendum A: US ASTM/D8169-2018 (Bi-Directional Static Axial Compressive Load Test of Piles):

- Clause 7,8 and (: Apparatus and Preparation for Measuring Loads, Measuring Movements and Procedure by Quick Test or Extended Test

ii. The Interpretation of YJACK test results. The reader shall refer to Addendum B: Singapore SS/CP4-2003 (Foundation, Pile Load Test):

- Clause 7.6.7: Bi-Directional Test using Built-In Load Cell Test.

iii. The theoretical background of the interpretations. The reader shall refer to Addendum C: US ASTM/D1143-2007 (Top Loaded Static Axial Compressive Load Test of Piles)

- The theoretical background of interpretation is simple, by just studying the pile load test behaviour in Load (Q) vs. Settlement (s), i.e Q~s Plot.

7.3 Term of Validity

This Technical Opinion Report shall become invalid and irrelevant in the event the product does not comply with relevant International Standards or any approved equivalent Standards currently in use. CIDB has the right to publicly announce any withdrawal related to this report subject to the terms above. This report is valid for three (3) years from the date of issuance.

8.0 APPROVED OPINION ABSTRACT

The Technical Expert Panel concludes that this product has a potential to be used in Malaysian construction industry. However, further research and development of the product performance in the local environment are encouraged.



Dr. Foo Chee Hung

Chairman

Technical Expert Panel

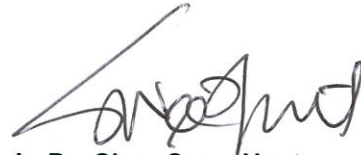

Ir. Dr. Chan Swee Huat

Technical Expert Panel



HM Dr. Abdul Aziz KM Hanifah

Technical Expert Panel

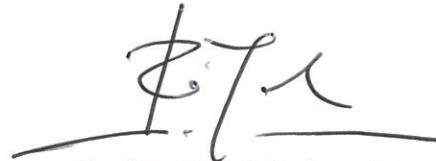

Prof. Dr. Mohd. Raihan Taha

Technical Expert Panel



Ir. Som Pong Pichan

Technical Expert Panel

International Award Winning New Innovation

YJACK Pile Test



STATIC METHOD
(CONVENTIONAL)



YJACK METHOD
(INNOVATIVE)

Expensive



Economical

Slow and Tedious



Fast and Simple

Large Work Platform



Environmental Green

Limited Test Load



Unlimited Test Load

Not for Offshore Piles



For All Types of Piles

Dangerous



Safe

The YJACK pile test is carried out in accordance to:
US, ASTM/D1143 (2007): Static Axial compressive Test
Singapore, SS/CP4 (2003): Foundation, Clause 7.6.7
Malaysia, JKR/20800 (2014): Foundation, Clause 2.9.4.2
UK, FPS/Handbook (2006): Pile Load Test, Table 4.1

YJACK Bored Piles



YJACK Driven Piles



CALL NOW For Presentation: 016-2168129 (Jimmy)

Malaysia • Indonesia • China • Singapore • Brunei • Thailand • Vietnam • Cambodia • India • Bangladesh



YJACK Technology Sdn Bhd (1086910-H)

25-2, Jalan Pandan Prima 1, Dataran Pandan Prima, 55100 Kuala Lumpur, Malaysia.

Tel: +6016-2168129 Fax: +603-92026811 E-mail: yjackpiletest@hotmail.com

www.YJACKpiletest.com

Company Overview

YJACK Technology is the world's leading pile test specialist with 25 years' experience. YJACK Technology is the only few worldwide companies competently to test 10 types of pile test methods (static, dynamic, imaging) especially for the new invented pile test method using YJACK bi-directional pile test.

Products & Services

Main Pile Testing: YJACK Pile Testing using bi-directional method on bored piles (Type B) and concrete piles (Type C). General Pile Testing: Dynamic Pile Testing such as high strain HS/PDA, low strain LS/PIT and sonic logging US/CSL

YJACK Pile Testing: Type B for Bored Piles



Bored Pile BP600Ø



Bored Pile BP1200Ø



Bored Pile BP1500Ø



Bored Pile BP2400Ø



End Bearing BP900Ø



Bored Pile BP2200Ø



Bored Pile BP1200Ø



Bored Pile BP1500Ø

YJACK Pile Testing: Type C for Concrete Piles



Driven Pile RC175□



Spun Pile SC300Ø



Driven Pile RC400□



End Bearing SC600Ø



End Bearing SC250Ø



Injection Pile SC300Ø



Driven Pile SC600Ø



Driven Pile SC600Ø

Dynamic Pile Testing

- | | |
|--|------|
| (1) High-Strain Pile Load Test (to determine pile load capacity and pile integrity) | [HS] |
| (2) Low-Strain Pile Integrity Test (to determine pile integrity on bored and concrete piles) | [LS] |
| (3) Ultra-Sonic Pile Integrity Test (to determine pile integrity on bored piles, also diaphragm walls) | [US] |
| (4) Hole-Profiling using Ultra-Sonic Imaging (to determine bored pile inner hole in 2D or 3D images) | [HP] |

Think YJACK. Think Pile Test.

REPORT # 1

YJACK VALIDATION TEST PROGRAM

STRUCTURAL LABORATORY TESTS

Prepared for:



YJACK TECHNOLOGY SDN BHD

Prepared by:



Issued Date:

2017 APR 01

Table of Contents

Cover Page	1
Table of Contents	2
Research Background	3
Test Objectives	4
Test Introduction	5
Test Setup	6
Compression Test	6
Bending Test	8
Test Criteria	11
Compression Test	11
Bending Test	11
Joint Test	11
Test Results	12
Compression Test	12
Bending Test	14
Joint Test	18
Conclusion	19
References	20

BENDING AND COMPRESSION TEST IN LABORATORY

Research Background

YJACK Technology is the world's leading pile test specialist with 25 year experiences. YJACK Technology is the only few worldwide companies competently to test 10 types of pile test methods (static, dynamic, imaging) especially for the new invented pile test using YJACK, the bi-directional pile test – a static pile load test method. It is an alternative and economical method to conventional maintained load test using Kentledge blocks or reaction piles methods.

This invention is by far the best compared to conventional method. The YJACK solves problems by:

- a. cost saving;
- b. time saving (from 10 days to 1 day in preparation);
- c. eco-friendly green and safe;
- d. suitable for all types of piles as well as offshore piles using autoYJACK.

[refer to Appendix A: A Glance of YJACK Brochure for details, www.YJACKpiletest.com]

There are four (4) types of YJACK series in design, i.e.:

- (1) YJACK Type C for driven closed ended piles (+ H-piles), International World Patented
- (2) YJACK Type O for driven open ended piles (+ offshore), International World Patented
- (3) YJACK Type B for cast in-situ bored piles, application since 1980; and
- (4) YJACK Type M for cast in-situ API-micro piles, application since 2014

The YJACK Type C and O are newly world patented technology in 2014, to conduct bi-directional pile load test on driven piles (and injection piles). Due to new technology, laboratory structural tests shall be conducted to ascertain the capabilities and performances of the YJACKs to function like a normal pile body during the pile installations.

Test Objectives

The YJACK is a component to be connected in spliced joint (in between to pile sections) which will be installed by pile driving hammer like a normal pile driving pile in to the ground.

In pile driving industry, assumed majority of 95% of the driven pile are land piling with closed ended design, hence YJACK Type C is selected to subject indoor laboratory compression and bending tests to comply the local Malaysian Standard for Precast Concrete Piles: MS/1314 (2004) and JKR Standard Specifications for Building Works: JKR/20800-0183 (2014).

The validation objectives are to ascertain:

- The YJACK is stronger than the land piling concrete piles in terms of compressive strength
- The YJACK is stronger than the land piling concrete piles in terms of bending strength
- The YJACK is stronger than the land piling concrete piles in terms of pile joint strength

Test Introduction

Pile sizes 300 and 400 mm diameter Spun Concrete, Grade 80, Class B piles were selected and subjected to compression and bending tests. The testing was carried out at the Heavy Structures Lab, Faculty of Civil Engineering, Universiti Teknologi MARA (University Technology MARA, UiTM), Shah Alam, Malaysia.

For compression tests, pile body SC300Ø (spun concrete pile body with 300mm diameter) were tested. The same compression tests were also carried out for pile connector YJ300Ø (YJACK, as pile connector to be connected at the pile joint).

Due to limitation of the laboratory facilities (in Malaysia) that unable to test high loading capacity, compression tests on SC400Ø and YJ400Ø were aborted, but the test replaced by the finite element modeling (FEM) analysis, and the results are presented in Test Report # 2.

[refer to Appendix B1: AutoCAD Drawings for Compression Test for details]

For bending tests, four (4) specimens were tested; 1st pair with pile size SC300Ø and YJ300Ø; 2nd pair with pile size SC400Ø and YJ400Ø. All piles were 6.0 m long. The test bending was conducted in accordance to Malaysian Standard for Precast Concrete Piles: MS/1314 (2004) and JKR Standard Specifications for Building Works: JKR/20800-0183 (2014).

[refer to Appendix B2: AutoCAD Drawings for Bending Test for details]

The piles (body) were manufactured by Industrial Concrete Product (ICP), with following material design:

- pile type: spun concrete (pile production by spinning process)
- pile design: Grade 80, Class B

The YJACK pile connectors were designed, fabricated and supplied by YJACK Technology Sdn Bhd. The steel plates material used are mild steel Grade 43.

The following sections will illustrate the laboratory test setups and test results.

Test Setup

Compression Test

The objective of the testing was to ensure that the compression capacity of the connectors is higher than the body of the piles.

Both piles and connectors were compression loaded using 2,000kN Universal Testing Machine (UTM). The schematic diagram of the test is illustrated in Figure 1(a). The specimen or sample length is 250mm.

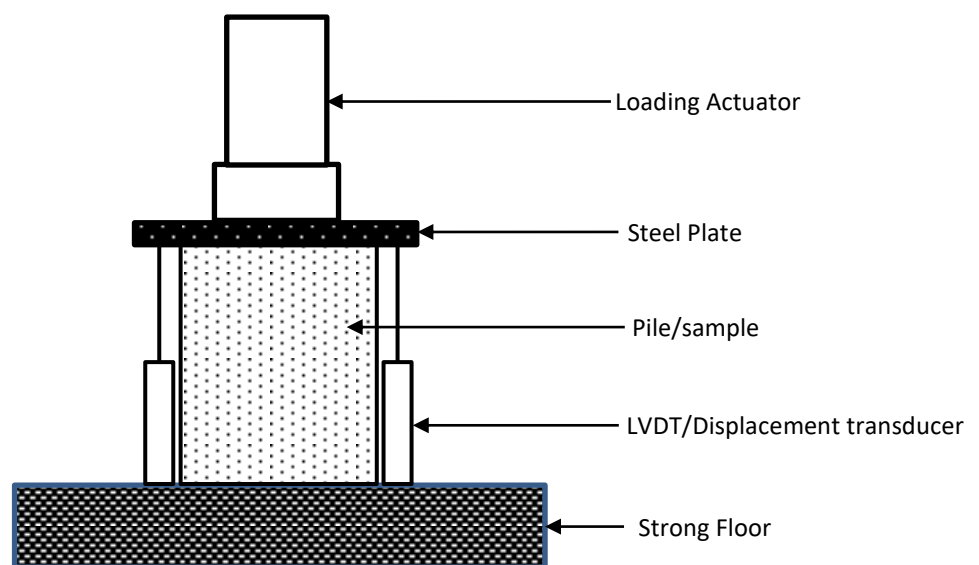

Figure 1(a)
Experimental Setup for Compression Test.

Prior to the compression tests, specimens were loaded up to 5kN and unloaded. This loading and unloading were repeated for five (5) times. This is to ensure that the specimens are completely sitting firmly in the test setup and to remove the initial softening material that is present prior to any structural testing. These load cycles are generally not considered as part of the tests. The specimens were then subjected to compression loading up to failure. Two (2) linear variable displacement transducers (LVDTs) were used to measure the vertical displacement of the specimens.

Figure 1(b) and Figure 1(c) show the pile body and pile connector (i.e. YJACK) respectively, mounted on the UTM machine prior to compression tests.



Figure 1(b)
Pile Body mounted on the UTM Machine prior to Compression Test



Figure 1(c)
Pile Connector mounted on the UTM Machine prior to Compression Test

Bending Test

The specimens were tested in 4 points bending in accordance to the specification given in Malaysian Standard for Precast Concrete Piles: MS/1314 (2004) and JKR Standard Specifications for Building Works: JKR/20800-0183 (2014).

Figure 2(a) shows the bending test setup. The 2 load points were at 1.2m apart and the reactions were at 3.6m apart.

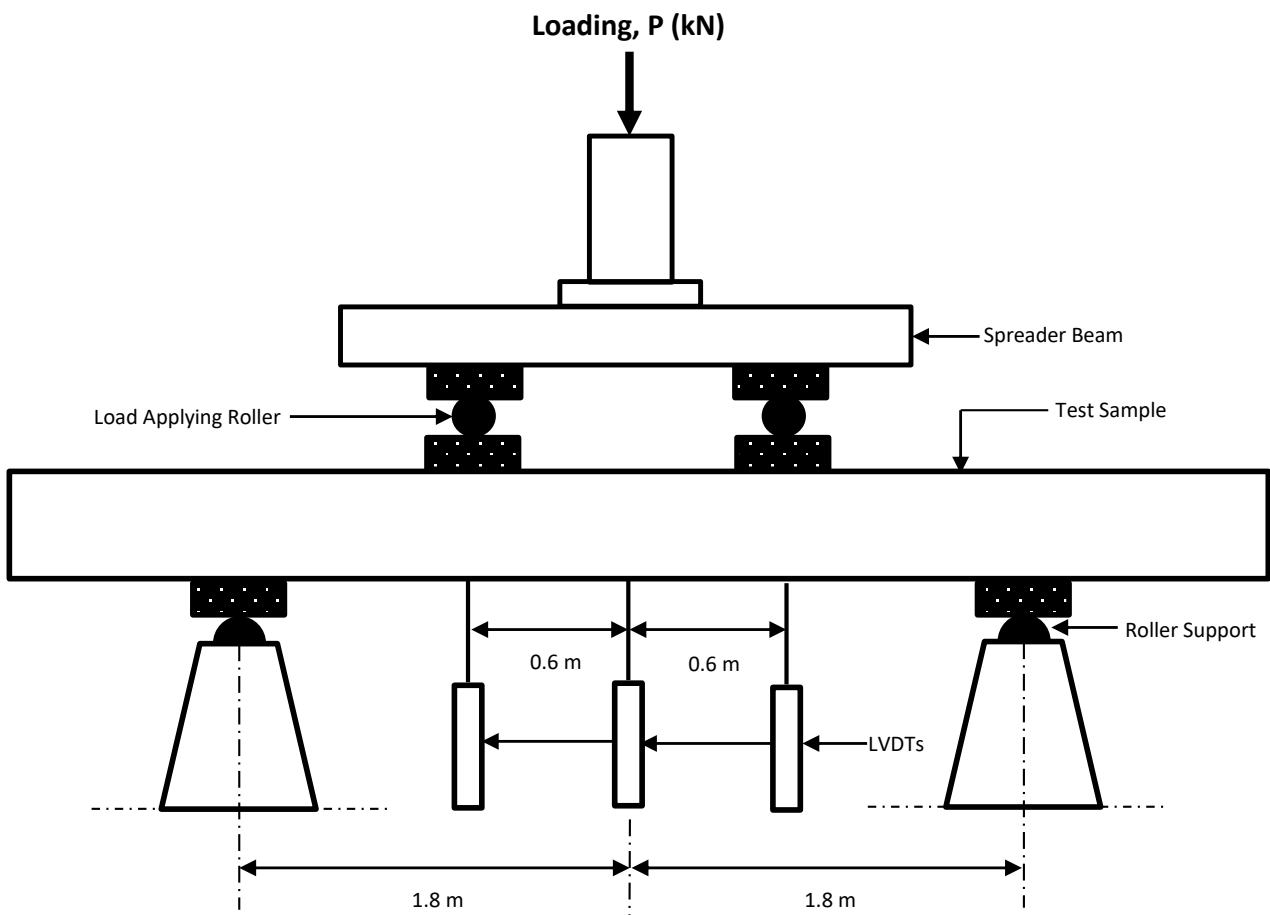

Figure 2(a)
Experimental Setup for Bending Test.

Figure 2B and Figure 2C show the pile body and connected pile (with pile connector) respectively, mounted on the roller supports prior to bending test.



Figure 2(b)
Pile Body mounted on the Roller Supports prior to Bending Test.



Figure 2(c)
YJACK Connected to Pile mounted on the Roller Supports prior to Bending Test.

Similar to the compression tests, specimens were loaded up to 5kN and unloaded for five (5) times to eliminate setting errors. The piles were then subjected to the failure load (P_{max}). During testing, close observations were made at cracking load, (P_c) and at minimum ultimate load (P_{min-u}). The crack width was measured using optical crack meter. In accordance to the standard, the (P_{max}) should not be less than (P_{min-u}).

The cracking load, P_c can be calculated from:

$$M_c = \frac{1}{40}WL + \frac{P_c}{4}\left(\frac{3L}{5} - 1\right)$$

where:

M_c is the applied bending moment (kNm)

W is the weight of the pile (kN)

L is the length of the pile (m)

P_c is the applied load with minimum crack width observed (kN)

$P_{(min-u)}$ is the minimum bending strength obtained by multiplying M_c by factor " f "

f is the M_c multiplying factor stated in MS1314 or determined by pile manufacturer

For pile type Spun Concrete, Grade 80, Class B:

- minimum crack width = 0.05 mm (Table C3 in JKR Specifications 2014)

Test Criteria

Compression Test

The ultimate load for compression tests for YJACK (the pile connector) shall be higher than the pile (body) with the following test criteria:

ICP SC Grade 80, Class B Pile Body*	Axial Working Load (kN)	Ultimate Compression Load (kN)
Spun Concrete SC300Ø	844 (= 86tn)	1,688 (=2X Working Load)
Spun Concrete SC400Ø	1501 (= 153tn)	3,002 (= 2X Working Load)

Manufactured by Industries Concrete Products (ICP), Spun Concrete, Grade 80, Class B

[refer to Appendix C: ICP Spun Concrete Pile Catalog for details]

Bending Test

The ultimate load for bending tests for YJACK (the pile connector) shall be higher than the pile (body) with the following test criteria:

ICP SC Grade 80, Class B Pile Body*	Crack Moment, Mc (kNm)	Equivalent Crack Load, Pc (kN)
Spun Concrete SC300Ø	23	34 (use L = 6m specimen)
Spun Concrete SC400Ø	54	80 (use L = 6m specimen)

Manufactured by Industries Concrete Products (ICP), Spun Concrete, Grade 80, Class B

[refer to Appendix C: ICP Spun Concrete Pile Catalog for details]

Joint Test

The strength of the joint shall be 10% higher than the bending test results.

Test Results

Compression Test

Figure 3(a) shows the load versus displacement (average value) for the SC300Ø. The ultimate load for the pile was found to be 1,588kN, which is slightly less than ultimate structural capacity as stated in the pile manufacturer catalog ($2 \times 844 = 1,688\text{kN}$).

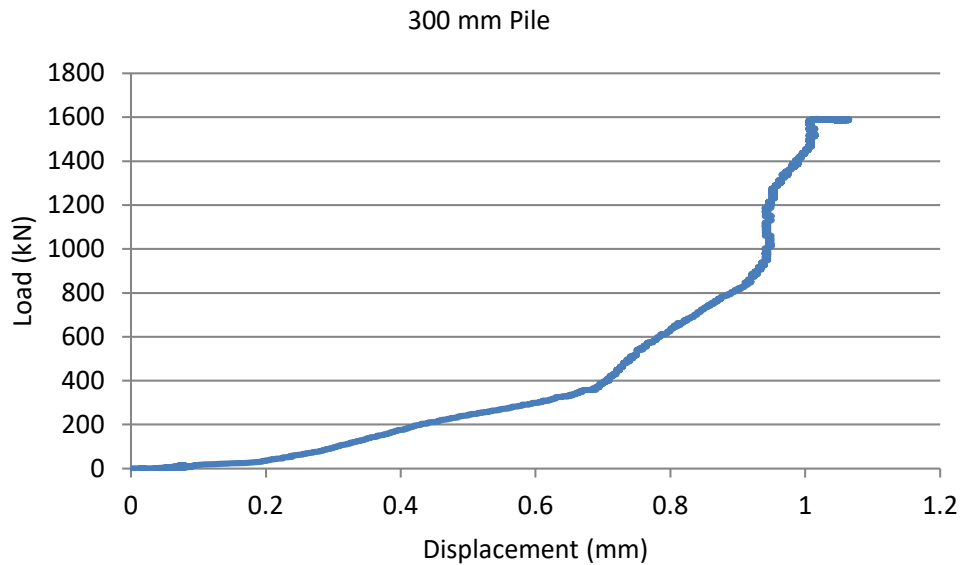

Figure 3(a)

Load-Displacement relationship for SC300Ø (300mm diameter spun pile body)
(Note: The graph is not a stress-strain plot, it is a normal compression load test plot)

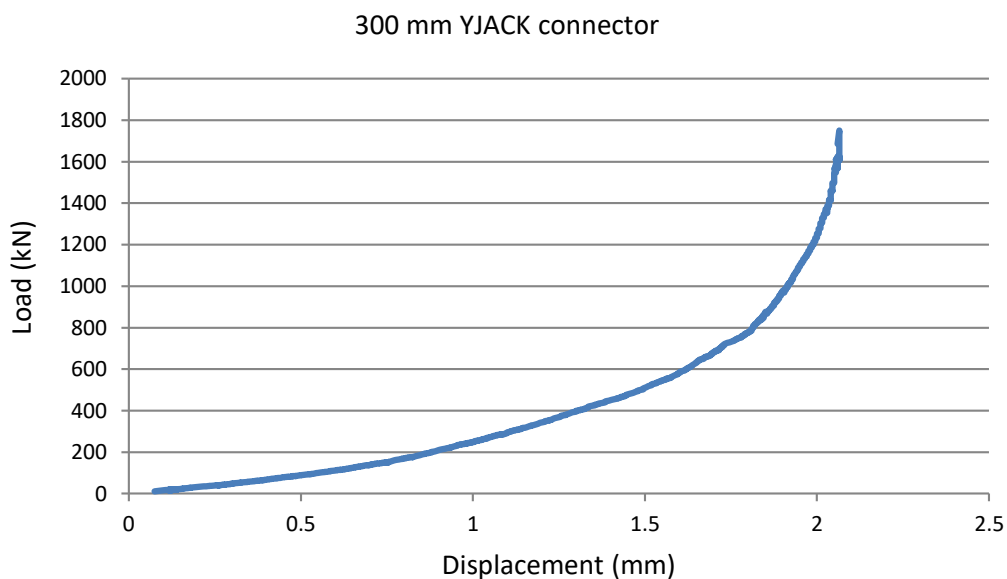

Figure 3(b)

Load-Displacement relationship for YJ300Ø (300mm diameter YJACK connector)
(Note: The graph is not 1 stress-strain plot, it is a normal compression load test plot)

Figure 3(b) shows the load versus displacement (average value) for the YJ300Ø. The ultimate load for the connector was found to be higher than 1,750kN. However, due to the limitation of the UiTM machine capacity, the testing was terminated. It should be noted that at this maximum load point, the specimen was observed to be intact and structurally sound.

The summary of the compression test results is tabulated in Table 1.

Table 1
Test Results for Ultimate Compression Load for Pile Body and YJACK Connector

Specimens	Technical Data Published by ICP Piles	Experimental Test Results
	Ultimate Compression Load (kN)	Ultimate Compression Load (kN)
SC300Ø (Spun Pile Body)	1,688	1,588*
YJ300Ø (YJACK Connector)	N/A	1,750 (3.7%)
SC400Ø (Spun Pile Body)	3,002	Not tested due to lab limitations (performed by FEM analysis)
YJ400Ø (YJACK Connector)	N/A	

* The test result is slightly lower to the technical data published in the catalog.

() The values in the bracket denote the variances of the experimental results

The percentage variance will be computed based on the following expression:

$$\% \text{variance} = (\# \text{experimental data} - \# \text{published data}) / \# \text{published data} * 100\%$$

Compression Test Summary

From the test results, it is confirmed that the capacity of the YJ300Ø connector is 3.7% higher than the SC300Ø pile body. Hence, the YJACK connector satisfies the compressive load requirement, i.e. the ultimate compressive load for the connector is higher than the ultimate compressive load for the pile body.

Due to limitation of the laboratory facilities (in Malaysia) that unable to test high loading capacity, compression tests on SC400Ø and YJ400Ø were aborted, but the test replaced by the finite element modeling (FEM) analysis, as described in the FEM Sections in Report # 2.

Bending Test

SC300Ø (pile body)

Test result of load-displacement (to failure) for SC300Ø is shown in Figure 3(a); whilst Figure 3(b) shows the failure test mod for the specimen.

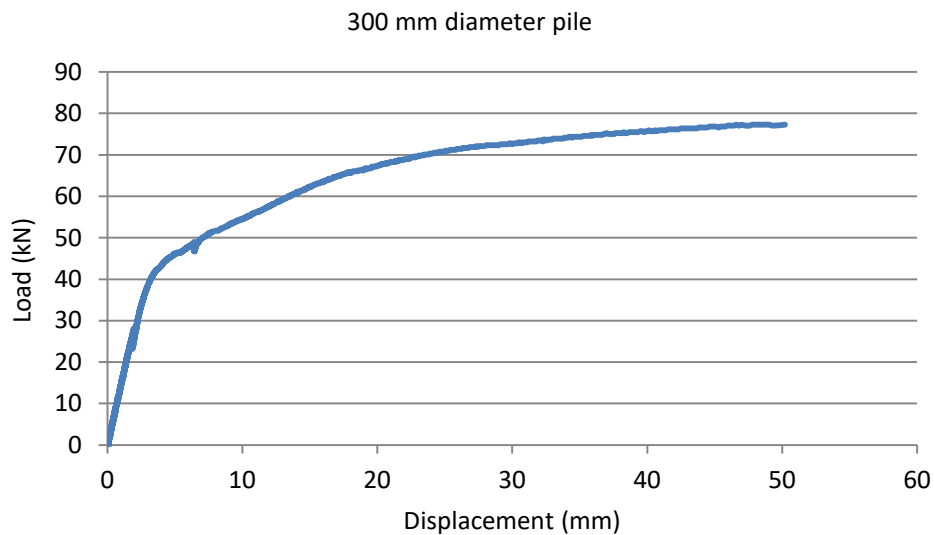

Figure 3(a)
Load-Displacement under Bending Test for SC300Ø (pile body)



Figure 3(b)
Failure Test Mod under Bending Test for SC300 Ø (pile body)

YJ300Ø (YJACK connector)

Test result of load-displacement (to failure) for YJ300Ø is shown in Figure 4(a); whilst Figure 4(b) shows the failure test mod for the specimen.

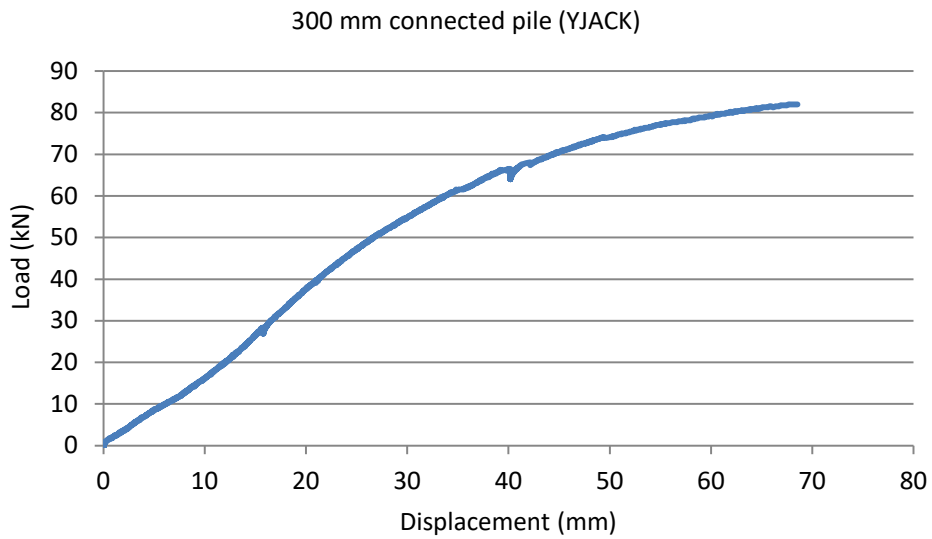

Figure 4(a)

Load-Displacement under Bending Test for YJ300Ø (YJACK Connector)



Figure 4(b)

Failure Test Mod under Bending Test for YJ300 Ø (YJACK Connector), failure occurred at concrete

SC400Ø (pile body)

Test result of load-displacement (to failure) for SC400Ø is shown in Figure 5(a); whilst Figure 5(b) shows the failure test mod for the specimen.

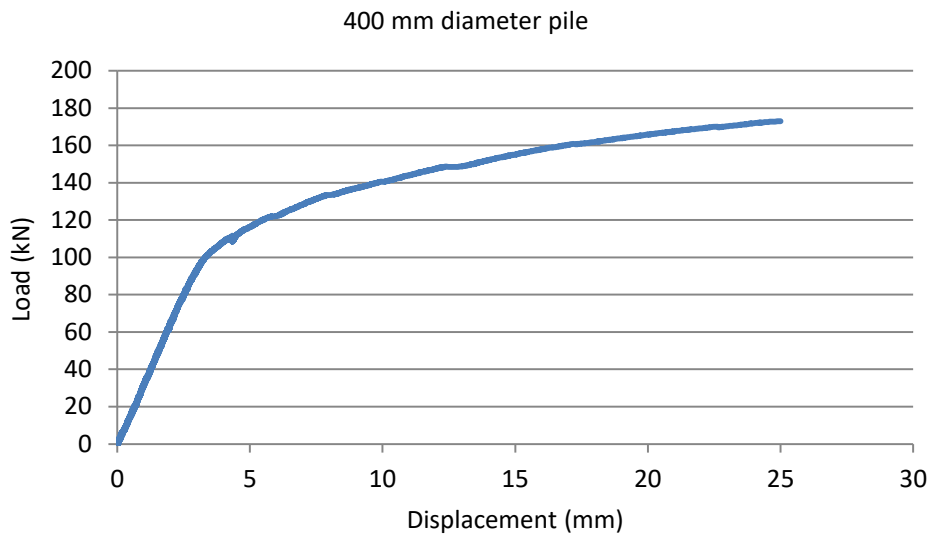

Figure 5(a)
Load-Displacement under Bending Test for SC400Ø (pile body)



Figure 5(b)
Failure Test Mod under Bending Test for SC400 Ø (pile body)

YJ400Ø (YJACK connector)

Test result of load-displacement (to failure) for YJ400Ø is shown in Figure 6(a); whilst Figure 6(b) shows the failure test mod for the specimen.

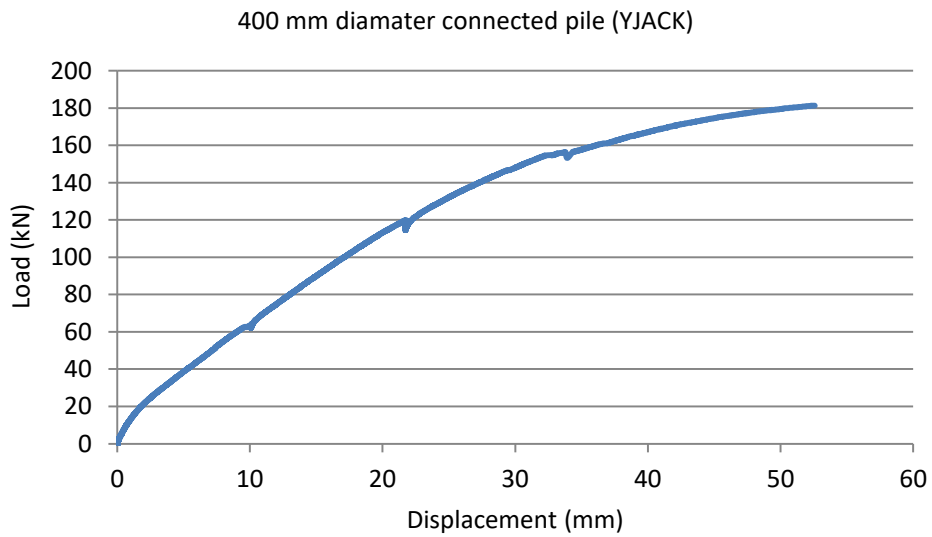

Figure 6(a)
Load-Displacement under Bending Test for YJ400Ø (YJACK Connector)



Figure 6(b)
Failure Test Mod under Bending Test for YJ400 Ø (YJACK Connector), failure occurred at concrete

The summary of the bending test results is tabulated in Table 2.

Table 2
Test Results for Ultimate Bending Load for Pile Body and YJACK Connector

Specimens	Technical Data Published by ICP Piles			Experimental Test Results	
	Crack Moment, M_c (kN)	Equivalent Crack Load, P_c (kN)	Ultimate Load, P_{max} (kN)	Crack Load, P_c (kN)	Ultimate Load, P_{max} (kN)
SC300Ø (Spun Pile Body)	23	34	61	41	77
YJ300Ø (YJACK Connector)	N/A	N/A	N/A	64 (88%)	81 (33%)
SC400Ø (Spun Pile Body)	54	80	140	107	172
YJ400Ø (YJACK Connector)	N/A	N/A	N/A	116 (45%)	181 (29%)

() The values in the bracket denote the variances of the experimental results

The percentage variance will be computed based on the following expression:

$$\% \text{variance} = (\# \text{experimental data} - \# \text{published data}) / \# \text{published data} * 100\%$$

Bending Test Summary

All the experimental test results indicated that the pile bodies for SC300Ø and SC400Ø have greater values compared to the published data.

All the experimental test results indicated that the YJACK connectors for YJ300Ø and YJ400Ø have greater values compared to the pile bodies (either published or experimental data), and satisfies the pile bending requirements.

Joint Test Summary

The bending tests indicated all the experimental results have 10% greater values than the published data. Hence the YJACK connector satisfies the pile joint requirements.

Conclusion

SC300Ø and SC400Ø ICP piles with and without connector were subjected to compression and bending test. For piles tested to bending, close observation was made at cracking load, minimum ultimate load and failure load.

For pile under compression load, SC300Ø ICP pile was found failed at 1,588kN (compared to published data of 1,688kN).

YJ300Ø YJACK connector was not tested up to the failure load (due to the limitations of the compressive machines), but it is confirmed that the ultimate load should be higher than the maximum test load of 1,750kN, and higher than the pile compressive strength.

Both SC300Ø and SC400Ø pile body and YJ300Ø and YJ400Ø pile with YJACK connector, under the bending tests, all experimental values for cracking and ultimate loads were found higher than both required by local standards and those published by pile manufacturer.

The bending tests indicated all the experimental results have 10% greater values than the published data. Hence the YJACK connector satisfies the pile joint requirements.

Conclusion Summary

YJ300Ø (YJACK connector):

- The YJACK is stronger than the land piling concrete piles in terms of compressive strength
- The YJACK is stronger than the land piling concrete piles in terms of bending strength
- The YJACK is stronger than the land piling concrete piles in terms of pile joint strength

YJ400Ø (YJACK connector):

- The YJACK is stronger than the land piling concrete piles in terms of compressive strength*
 - The YJACK is stronger than the land piling concrete piles in terms of bending strength
 - The YJACK is stronger than the land piling concrete piles in terms of pile joint strength
- (* refer to finite element modeling (FEM) analysis results presented in Test Report # 2)

References

1. BS-EN/12390-3 (2009): Testing Hardened Concrete for Compressive Strength
2. MS/1314 (2004): Malaysian Standard for Precast Concrete Piles
3. JKR/20800-0183 (2014): JKR Standard Specifications for Building Works
4. ICP/Catalog (2016): High Performance Pretension Spun Concrete Piles

APPENDIX A

International Award Winning New Innovation

YJACK Pile Test

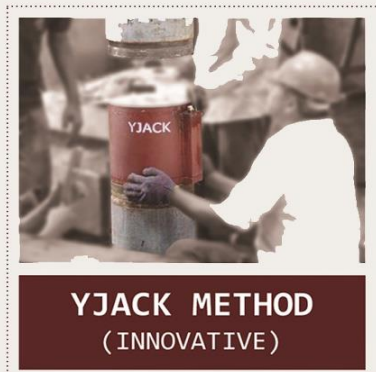

Expensive

Slow and Tedious

Large Work Platform

Limited Test Load

Not for Offshore Piles

Dangerous



Economical

Fast and Simple
(10 days to 1 day time saving)

Environmental Green

Unlimited Test Load

For All Types of Piles

Safe

The YJACK pile test is carried out in accordance to:
US, ASTM/D1143 (2007): Static Axial compressive Test
Singapore, SS/CP4 (2003): Foundation, Clause 7.6.7
Malaysia, JKR/20800 (2014): Foundation, Clause 2.9.4.2
UK, FPS/Handbook (2006): Pile Load Test, Table 4.1

YJACK Bored Piles



YJACK Driven Piles



CALL NOW For Presentation: www.YJACKpiletest.com

Malaysia • Indonesia • China • Singapore • Cambodia • Thailand • Vietnam • India • Middle East



YJACK Technology Sdn Bhd (1086910-H)
25-2, Jalan Pandan Prima 1, Dataran Prima, 55100 Kuala Lumpur, Malaysia.
Tel: +60-3-92868211 Fax: +60-3-92026811

www.YJACKpiletest.com

APPENDIX B

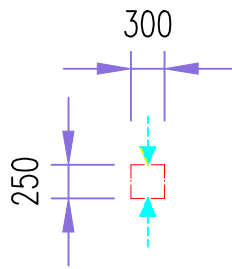

PILE MATERIAL : 300MM DIAM. SPUN PILE GRADE 80 CLASS B
 TEST : COMPRESSION ON PILE MATERIAL

PROJECT TITLE:
 FABRICATION AND DELIVERY OF YJACK
 300MM & 400MM DIAMETER AND SPUN
 PILE 300MM & 400MM DIAMETER, FOR
 PURPOSE OF COMPRESSIVE AND
 BENDING LAB TEST TO COMPLY TO JKR
 SPECIFICATION 2014

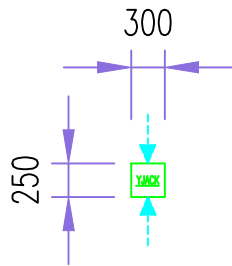

JACK MATERIAL : 400MM DIAM. MILD STEEL GRADE 43
 TEST : COMPRESSION TEST ON YJACK MATERIAL

DATE	DESCRIPTION	REV.

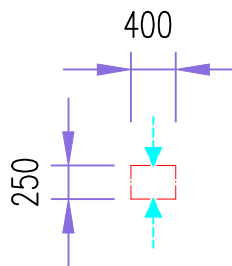

PILE MATERIAL : 400MM DIAM. SPUN PILE GRADE 80 CLASS B
 TEST : COMPRESSION ON PILE MATERIAL

DRAWING TITLE:
 COMPRESSIVE TEST ON PILE MATERIAL
 VS. YJACK MATERIAL

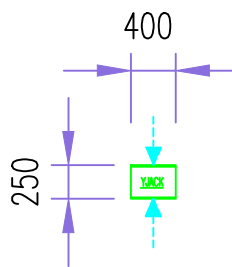

JACK MATERIAL : 400MM DIAM. MILD STEEL GRADE 43
 TEST : COMPRESSION TEST ON YJACK MATERIAL

DRAWN BY: YAU KIM WEI	25 MAY 2016
CHECKED BY: WAI YEKONG	31 MAY 2016

REF: YJACK/2016/UTHM/02/REV.1

	<p>PILE MATERIAL : 300MM DIAM. SPUN PILE GRADE 80 CLASS B</p> <p>TEST : BENDING TEST ON PILE MATERIAL</p>	<p>PROJECT TITLE:</p> <p>FABRICATION AND DELIVERY OF YJACK 300MM & 400MM DIAMETER AND SPUN PILE 300MM & 400MM DIAMETER, FOR PURPOSE OF COMPRESSIVE AND BENDING LAB TEST TO COMPLY TO JKR SPECIFICATION 2014</p>												
	<p>PILE MATERIAL : 300MM DIAM. SPUN PILE GRADE 80 CLASS B</p> <p>TEST : BENDING TEST ON YJACK MATERIAL</p>	<table border="1"> <tr> <td></td> <td></td> <td></td> </tr> <tr> <td></td> <td></td> <td></td> </tr> <tr> <td></td> <td></td> <td></td> </tr> <tr> <th>DATE</th> <th>DESCRIPTION</th> <th>REV.</th> </tr> </table>										DATE	DESCRIPTION	REV.
DATE	DESCRIPTION	REV.												
	<p>PILE MATERIAL : 400MM DIAM. SPUN PILE GRADE 80 CLASS B</p> <p>TEST : BENDING TEST ON PILE MATERIAL</p>	<p>DRAWING TITLE:</p> <p>BENDING TEST ON PILE MATERIAL VS. YJACK MATERIAL</p>												
	<p>PILE MATERIAL : 400MM DIAM. SPUN PILE GRADE 80 CLASS B</p> <p>TEST : BENDING TEST ON YJACK MATERIAL</p>	<table border="1"> <tr> <td>DRAWN BY: YAU KIM WEI</td> <td>25 MAY 2016</td> </tr> <tr> <td>CHECKED BY: WAI YEKONG</td> <td>31 MAY 2016</td> </tr> <tr> <td></td> <td></td> </tr> <tr> <td colspan="2">REF: YJACK/2016/UTHM/01/REV.1</td> </tr> </table>	DRAWN BY: YAU KIM WEI	25 MAY 2016	CHECKED BY: WAI YEKONG	31 MAY 2016			REF: YJACK/2016/UTHM/01/REV.1					
DRAWN BY: YAU KIM WEI	25 MAY 2016													
CHECKED BY: WAI YEKONG	31 MAY 2016													
REF: YJACK/2016/UTHM/01/REV.1														

APPENDIX C



PROPERTIES OF ICP PILES

GRADE 80 PILES

GRADE 90 PILES

CLASS A (EFFECTIVE PRESTRESS ≥ 4.0 N/mm²)

Nominal Diameter mm	Nominal Thickness mm	Length m	Nominal Weight kg/m	Prestressing Bar			Area of Concrete mm ²	Section Modulus x1000 mm ³	Bending Moment		Recommended Max Structural Axial Working Load (For a short strut) ton	Effective Prestress N/mm ²
				7.1mm no.	9.0mm no.	10.7mm no.			Cracking kNm	Ultimate kNm		
300	60	6-12	118	6	-	-	45,239	2,373	21.3	34.8	87	4.9
350	60	6-12	142	8	-	-	54,664	3,533	32.9	54.1	104	5.3
400	65	6-12	178	8	-	-	68,408	5,106	42.7	61.8	132	4.3
450	70	6-12	217	10	-	-	83,566	7,113	60.4	86.9	161	4.5
500	80	6-12	274	12	-	-	105,558	9,888	82.3	115.9	204	4.3
600	90	6-12	375	-	12	-	144,199	16,586	148.8	222.5	276	5.0

CLASS B (EFFECTIVE PRESTRESS ≥ 5.0 N/mm²)

Nominal Diameter mm	Nominal Thickness mm	Length m	Nominal Weight kg/m	Prestressing Bar			Area of Concrete mm ²	Section Modulus x1000 mm ³	Bending Moment		Recommended Max Structural Axial Working Load (For a short strut) ton	Effective Prestress N/mm ²
				7.1mm no.	9.0mm no.	10.7mm no.			Cracking kNm	Ultimate kNm		
250	55	6-12	88	6	-	-	33,694	1,435	14.9	29.0	63	6.4
300	60	6-12	118	7	-	-	45,239	2,383	22.9	40.6	86	5.6
350	70	6-12	160	9	-	-	61,575	3,778	35.6	60.8	117	5.4
400	80	6-15	209	12	-	-	80,425	5,643	53.7	92.7	153	5.5
450	80	6-15	242	-	8	-	92,991	7,624	70.0	111.2	177	5.2
500	90	6-15	301	-	10	-	115,925	10,518	95.9	154.5	221	5.1
600	100	6-15	408	-	14	-	157,080	17,546	163.1	259.6	299	5.3
700	110	6-18	530	-	20	-	203,889	27,131	265.1	432.6	386	5.8
800	120	6-18	667	-	24	-	256,354	39,455	376.8	593.3	487	5.5
900	130	6-18	818	-	28	-	314,473	54,942	510.3	778.7	599	5.3
1000	140	6-18	983	-	-	24	378,248	74,056	688.9	1042.8	720	5.3
1200	150	6-18	1286	-	-	36	494,801	120,188	1198.5	1877.1	934	6.0

CLASS C (EFFECTIVE PRESTRESS ≥ 7.0 N/mm²)

Nominal Diameter mm	Nominal Thickness mm	Length m	Nominal Weight kg/m	Prestressing Bar				Area of Concrete mm ²	Section Modulus x1000 mm ³	Bending Moment		Recommended Max Structural Axial Working Load (For a short strut) ton	Effective Prestress N/mm ²
				7.1mm no.	9.0mm no.	10.7mm no.	12.6mm no.			Cracking kNm	Ultimate kNm		
250	55	6-12	88	7	-	-	-	33,694	1,443	16.2	33.8	63	7.2
300	60	6-12	118	10	-	-	-	45,239	2,416	28.0	57.9	84	7.6
350	70	6-15	160	-	8	-	-	61,575	3,826	43.0	86.5	114	7.2
400	80	6-15	209	-	12	-	-	80,425	5,748	69.7	148.3	147	8.1
450	80	6-15	242	-	12	-	-	92,991	7,734	86.9	166.9	173	7.2
500	90	6-18	301	-	15	-	-	115,925	10,670	120.3	231.7	215	7.3
600	100	6-30	408	-	-	14	-	157,080	17,761	196.4	365.0	292	7.0
700	110	6-46	530	-	-	20	-	203,889	27,498	320.6	608.3	376	7.6
800	120	6-46	667	-	-	24	-	256,354	39,966	454.7	834.3	475	7.4
900	130	6-46	818	-	-	28	-	314,473	55,622	617.7	1095.0	584	7.1
1000	140	6-46	983	-	-	36	-	378,248	75,188	864.5	1564.3	699	7.5
1200	150	6-36	1286	-	-	46	-	494,801	121,361	1378.6	2398.6	916	7.3
1000	140	6-46	983	-	-	-	34	378,248	76,247	961.1	2051.9	688	8.6
1200	150	6-36	1286	-	-	-	46	494,801	123,457	1583.1	3331.3	898	8.8

CLASS A (EFFECTIVE PRESTRESS ≥ 4.0 N/mm²)

Nominal Diameter mm	Nominal Thickness mm	Length m	Nominal Weight kg/m	Prestressing Bar			Area of Concrete mm ²	Section Modulus x1000 mm ³	Bending Moment		Recommended Max Structural Axial Working Load (For a short strut) ton	Effective Prestress N/mm ²
				7.1mm no.	9.0mm no.	10.7mm no.			Cracking kNm	Ultimate kNm		
300	60	6-12	118	6	-	-	45,239	2,373	21.9	34.8	98	4.9
350	60	6-12	142	8	-	-	54,664	3,533	33.8	54.1	118	5.3
400	65	6-12	178	8	-	-	68,408	5,106	43.9	61.8	149	4.3
450	70	6-12	217	10	-	-	83,566	7,113	62.2	86.9	182	4.5
500	80	6-12	274	12	-	-	105,558	9,888	84.8	115.9	231	4.3
600	90	6-12	375	-	12	-	144,199	16,586	152.9	222.5	313	5.0

CLASS B (EFFECTIVE PRESTRESS ≥ 5.0 N/mm²)

Nominal Diameter mm	Nominal Thickness mm	Length m	Nominal Weight kg/m	Prestressing Bar			Area of Concrete mm ²	Section Modulus x1000 mm ³	Bending Moment		Recommended Max Structural Axial Working Load (For a short strut) ton	Effective Prestress N/mm ²
				7.1mm no.	9.0mm no.	10.7mm no.			Cracking kNm	Ultimate kNm		
250	55	6-12	88	6	-	-	33,694	1,435	15.3	29.0	72	6.4
300	60	6-12	118	7	-	-	45,239	2,383	23.5	40.6	97	5.6
350	70	6-12	160	9	-	-	61,575	3,778	36.5	60.8	133	5.4
400	80	6-15	209	12	-	-	80,425	5,643	55.0	92.7	173	5.5
450	80	6-15	242	-	8	-	92,991	7,624	71.9	111.2	201	5.2
500	90	6-15	301	-	10	-	115,925	10,518	98.5	154.5	251	5.1
600	100	6-15	408	-	14	-	157,080	17,546	167.3	259.6	339	5.3

FORMULA FOR AXIAL LOAD

Based on BS 8004: 1986, the maximum allowable axial stress that may be applied to a pile acting as a short strut should be one quarter of (specified works cube strength at 28 days less the prestress after losses)

$$N = f_{ca} \times A$$

$$= 1/4 (f_{cu} - f_{pe}) \times A$$

Where, N = maximum allowable axial load

A = cross section area of concrete

f_{ca} = permissible compressive strength of concrete

f_{cu} = specified compressive strength of concrete

f_{pe} = effective prestress in concrete

(Subject to change without prior notice)

REPORT 2

YJACK VALIDATION TEST PROGRAM

FINITE ELEMENT MODELING

Prepared for:



YJACK TECHNOLOGY SDN BHD

Prepared by:



Issue Date:

2017 APR 01

CONTENTS

Compression Analysis	3
Model Information.....	3
Study properties	3
Units.....	4
Material Properties.....	4
Fixture Load.....	4
Mesh Information - Details.....	5
Study Results	6
Bending Analysis.....	
Conclusion.....	1

SIMULATION AND FINITE ELEMENT ANALYSIS

FEM Objectives

Further to Test Report # 1, the objectives of the FEM are to ascertain:

- The YJACK is stronger than the land piling concrete piles in terms of compressive strength
- The YJACK is stronger than the land piling concrete piles in terms of bending strength

Compression Analysis

YJACK is a newly world patented jack specially designed for bi-directional (BD) static pile load test on driven piles (Patent #: PI2014000539). Professional YJACK adopts capsule sealing technology (Patent #: CN201694784U). That gives a more reasonable product value which avoids too wasteful long life of normal sacrificed test jacks. Meanwhile it offers lower height, larger loading area, lower oil pressure and safer loading results.

YJACK is designed to load low pressure (20-40MPa) onto pile body to ensure the pressure applied on the pile is less than the pile structural capacity (for concrete piles). YJACK comprises by two main components; the cylinder shell (red color) and piston shell (grey color). In this simulation, piston shell was selected to be analyzed up to 1,750kN of force and checked for the displacement and safety. This 1,750kN was the maximum applied load on the YJACK specimen as described in Test Report # 1.

Model Information

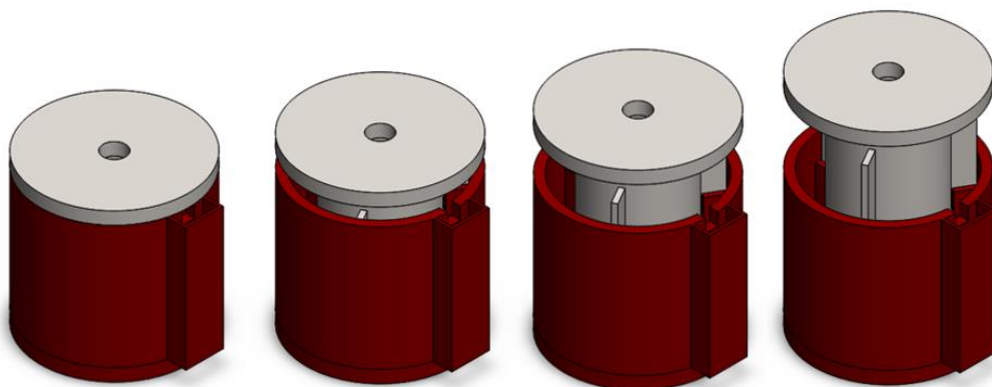

Figure 4: Part Modelling

Study Properties

Analysis type	Static
Mesh type	Solid Mesh
Thermal Effect:	On
Thermal option	From thermal study
Zero strain temperature	298 K

Units

Unit system:	SI (MKS)
Length/Displacement	mm
Temperature	Kelvin
Angular velocity	Rad/sec
Pressure/Stress	N/m ²

Material Properties

Model Reference	Properties	
	Name:	AISI 1020
	Model type:	Linear Elastic Isotropic
	Yield strength:	3.51571e ⁺⁰⁰⁸ N/m ²
	Tensile strength:	4.20507e ⁺⁰⁰⁸ N/m ²
	Elastic modulus:	2e ⁺⁰¹¹ N/m ²
	Poisson's ratio:	0.29
	Mass density:	7900 kg/m ³
	Shear modulus:	7.7e ⁺⁰¹⁰ N/m ²
Thermal expansion coefficient:	1.5e ⁻⁰⁰⁵ /Kelvin	

Fixture and Load

Fixture	Bottom plate
Load	Top plate
Load value [kN]	200, 400, 600, 800, 1000, 1200, 1400, 1600, 1750
Diameter [mm]	300, 400

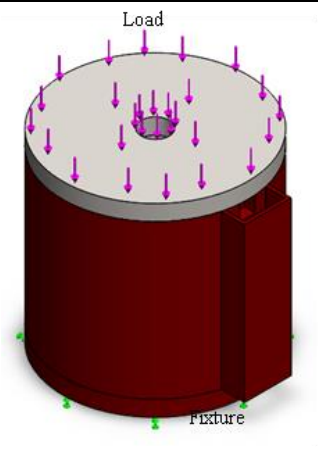
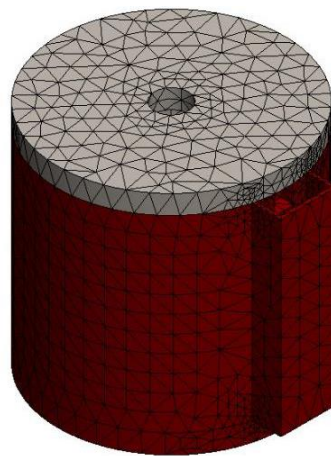

Figure 5: Fixture and load for compression analysis**Mesh Information - Details**

Total Nodes	28971
Total Elements	15714
Maximum Aspect Ratio	155.22
% of elements with Aspect Ratio < 3	85.7
% of elements with Aspect Ratio > 10	0.7
% of distorted elements(Jacobian)	0

**Figure 6: Meshed model for compression analysis**

Study Results

Table 1 Static study analysis for 300 mm YJACK

Force	kN	0	200	400	600	800	1000	1200	1400	1600	1750
Displacement	cm	0	0.0038	0.0075	0.0113	0.0150	0.0188	0.0225	0.0263	0.0301	0.0329
Stress	MPa	0	44.9	89.9	134.8	179.8	224.7	269.6	314.6	359.5	393.2
Minimum Factor of Safety		0	7.82	3.91	2.61	1.96	1.56	1.3	1.12	0.98	0.89

Table 2 Static study analysis for 400 mm YJACK

Force	kN	0	250	500	750	1000	1250	1500	1750
Displacement	cm	0	0.009	0.018	0.027	0.036	0.044	0.053	0.062
Stress	MPa	0	60.6	121.2	181.8	242.3	302.9	363.5	424.1
Minimum Factor of Safety		0	5.8	2.9	1.93	1.45	1.16	0.97	0.83

Table 1 and Table 2 show the results of the static study analysis for 300 mm and 400 mm YJACK respectively. Force increments for both cases had been intentionally differentiated to show the slight differences in the results for specified forces. The displacements were increased with the increasing force. Displacement for 400 mm when the force was 1,750 kN was about 1 times higher than that for 300 mm.

Plot for Displacement and Factor of Safety in the case of 300 mm and 400 mm YJACK are shown in Figure 7 (a) and (b) respectively. Factor of Safety indicates the ratio between the yield strength of the materials and allowable stress applied on the materials or the structure. Stress must be lower than the Yield Strength to ensure the safety of the structure. The standard factor of safety will be depended on the condition where the structure is used and typically ranging between 2 to 4 for normal condition and must not too high as it will be led to the over design. The selection of materials and design for specific structure is very much important for the determination of safety factor. Based on the results obtained from the static analysis, the minimum factors of safety were ranging between 1.12 to 7.82 when the forces were lower than 1,400 kN. However, it decreased to 0.89 when the force was increased up to 1,750 kN. The factor of safety decreased in the case of 400 mm compared to that of 300 mm. The location of the minimum factor of safety is shown in Figure 9. It was at the inner side of the YJACK. This is expected to be improved in the actual condition where the inner part of the YJACK will be fully filled up with concrete and this could support the affected area and able to avoid the part from failure.

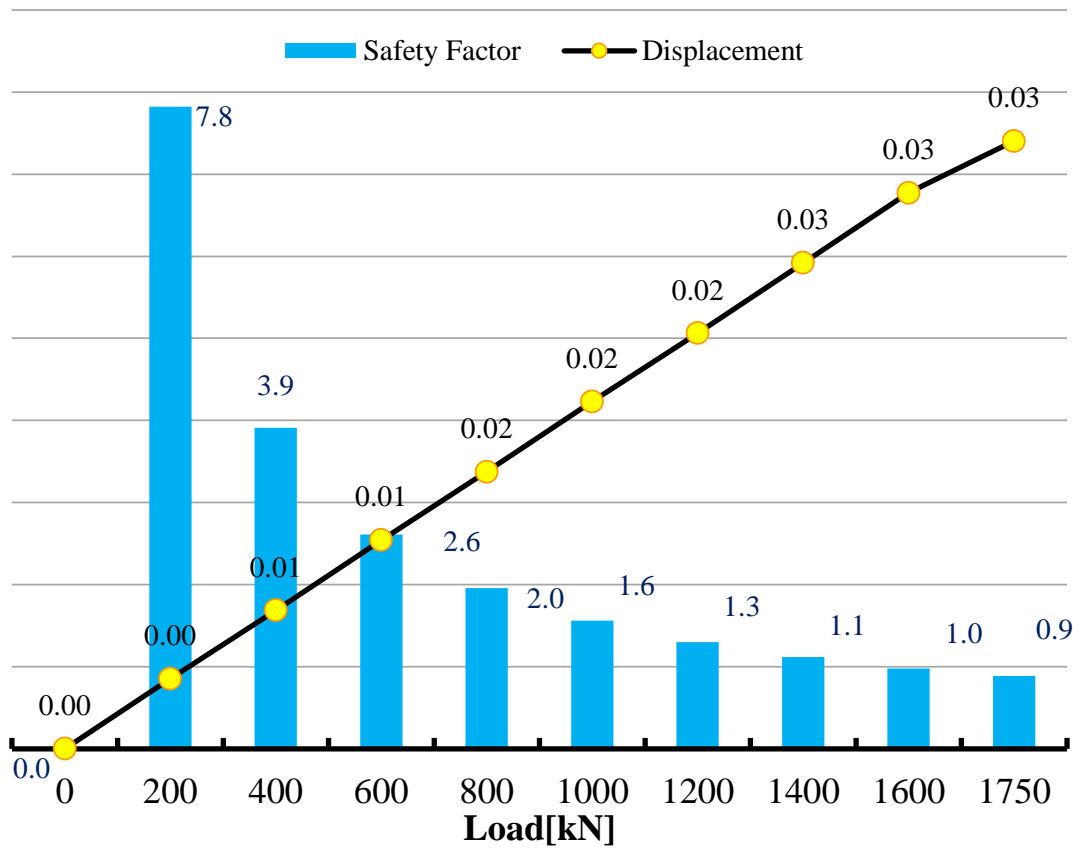

(a)

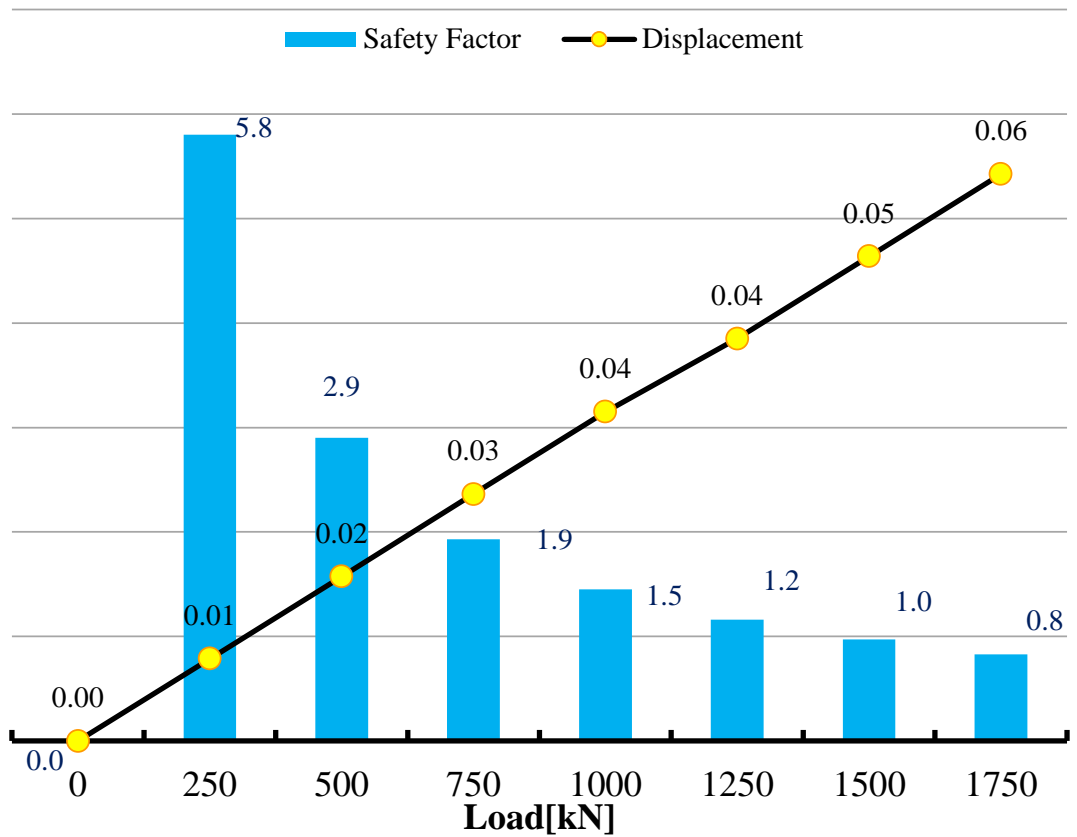

(b)

Figure 7: Safety factor and displacement for each applied load; (a) 300 mm, (b) 400 mm.

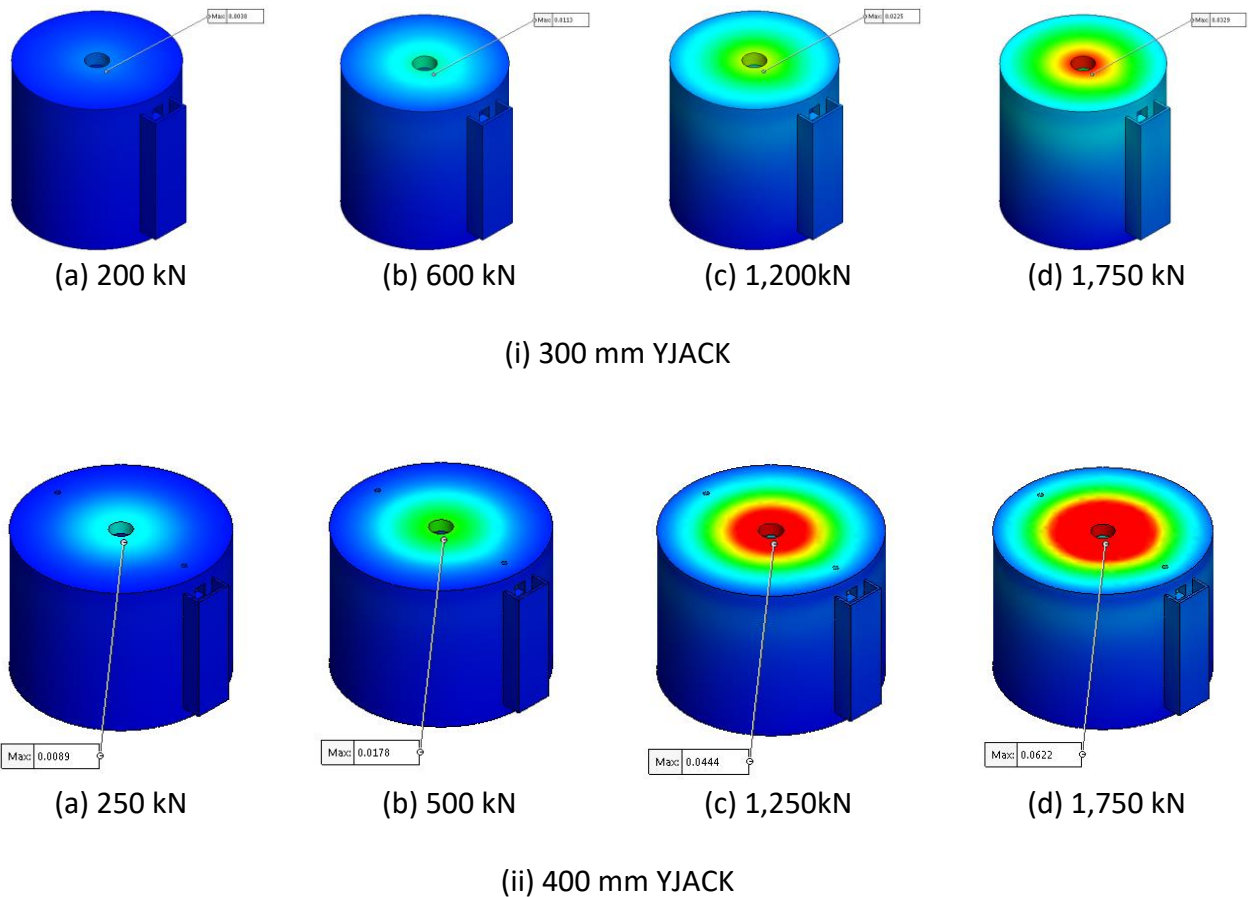
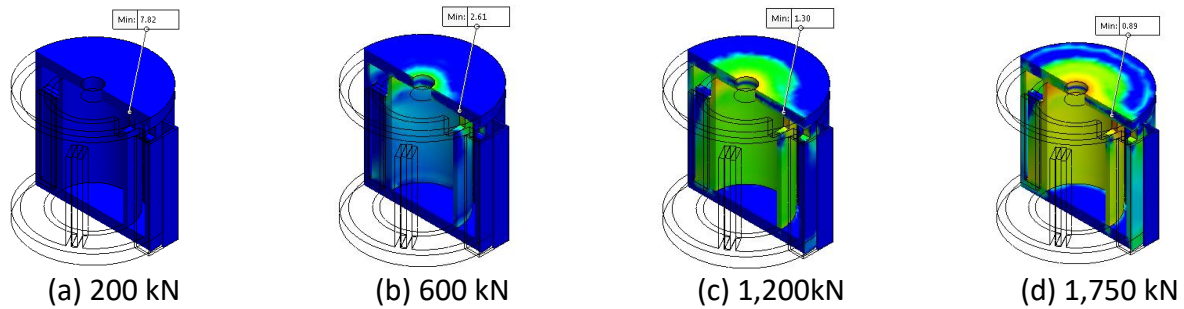
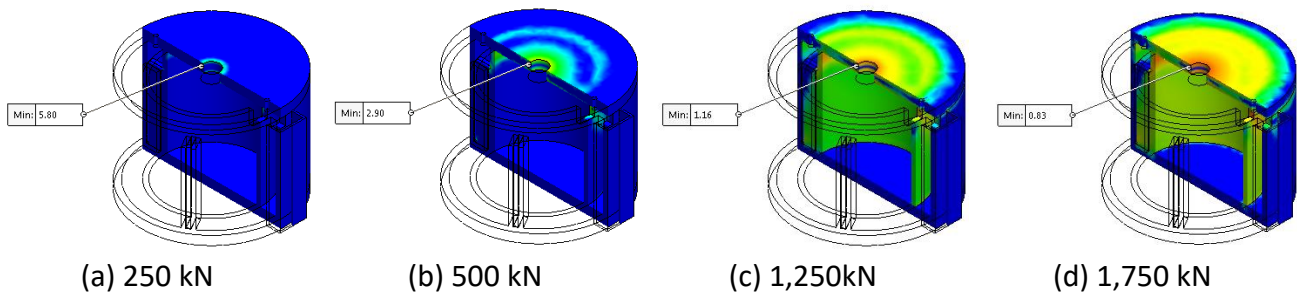

Figure 8: Changes of displacement with increasing loads.

Figure 8 shows the changes of displacement with changing loads. The maximum displacement was recorded at the area near to the hole. The displacement for 400 mm YJACK was higher than that for 300 mm. However, the displacement is expected to decrease in the actual condition due to the insertion of concrete inside the YJACK during on-site installation. The concrete will supports and prevent the YJACK from any notable displacement.



(i) 300 mm YJACK



(ii) 400 mm YJACK

Figure 9: Changes of safety factors with increasing loads.

Figure 9 shows the cross section of the YJACK during compression for 300 mm and 400 mm YJACK. The most critical point is the point labelled with “Min”. The safety factor for 1,750 kN load were very low. The safety factor for 400 mm YJACK was slightly lower than that for 300 mm. If the YJACK is used as in the simulation, it is expected to fail due to excessive stress applied on it. But, since the actual application of YJACK is by fully filling the empty space inside YJACK with concrete, the safety factor might significantly increase and able to prevent the failure.

Bending Analysis

Figure 10(a) shows a schematic diagram of four points bending moment of YJACK. The piles are roller-supported at both ends and the forces are applied at a distance of 0.6 m measured from the middle plane. While Figure 10(b) reveals finite element model of YJACK/Pile configuration. In this work, static linear finite element analysis is used to simulate the problem.

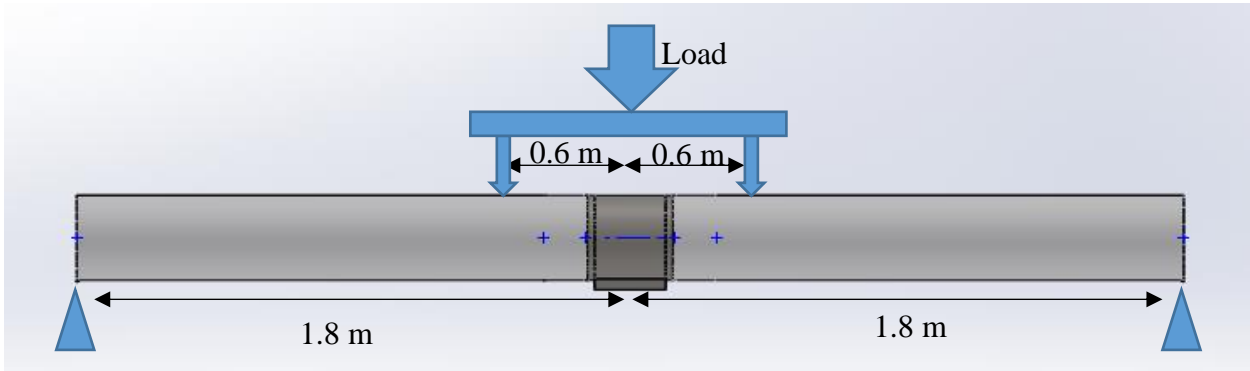

Figure 10 (a) Schematic diagram of YJACK/Piles configuration

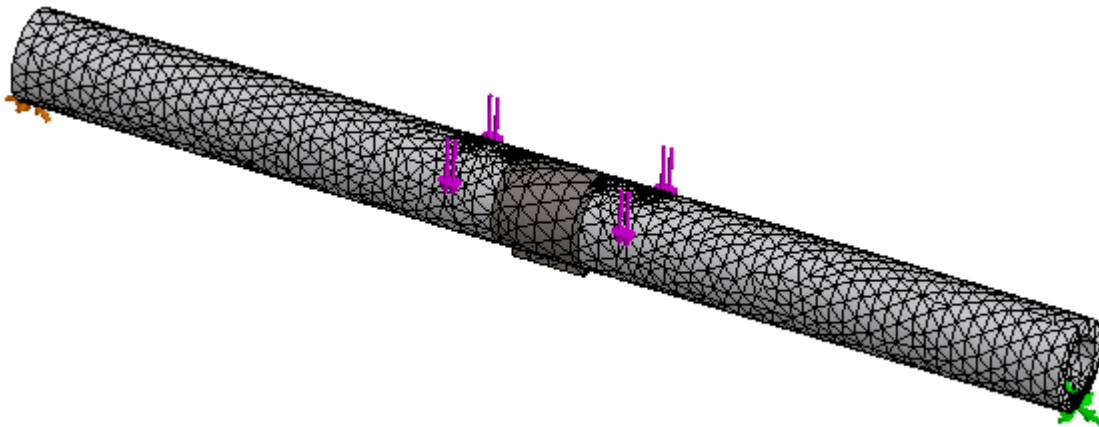

Figure 10 (b) Corresponding finite element model.

After the problem is solved, the result is shown in Figure 11. It is revealed that most of the damages occurred at the region of connections between piles and YJACK. The weak region can be observed at the bottom side of YJACK/Piles since concrete is weakened under the action of tension.

According to Figure 11 (as in enlarged figure), the probability of connection between YJACK and pile disintegrated is relatively high especially at the bottom edge.

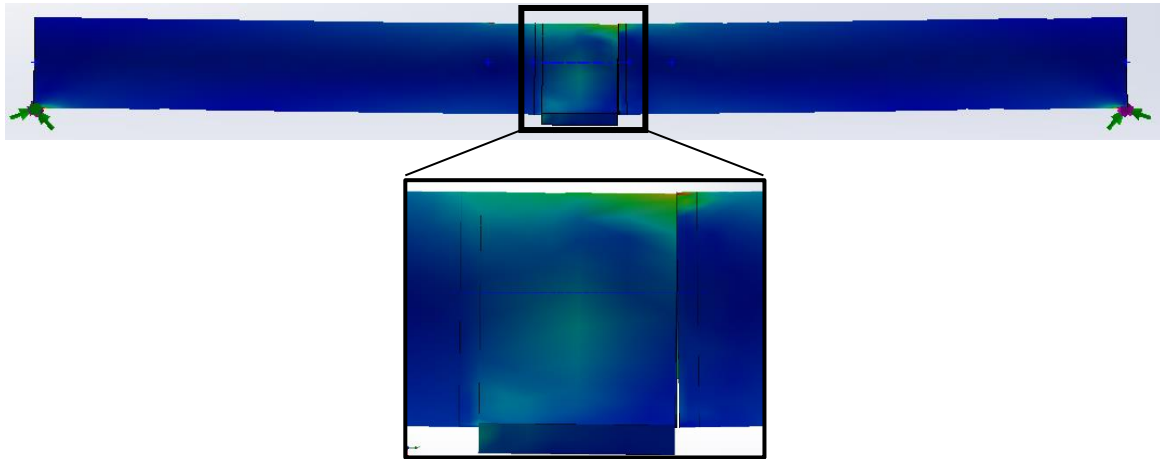

Figure 11: Simulation results of YJACK/Piles configuration

In order to fully understand the role of connection between two different materials, Figure 12 and Figure 13 respectively indicate the variations of safety factors across the YJACK/Piles system for 300 and 400 mm YJACK. Based on the results obtained from finite element analysis, similar behaviour of safety factors can be observed where the minimum values occurred at the junction between YJACK/Pile systems. Minimum safety factors are also observed at the bottom side of piles and it is predicted the disintegrations probably occurs at such locations.



Figure 12: 300 mm YJACK model (a) finite element model and (b) finite element result

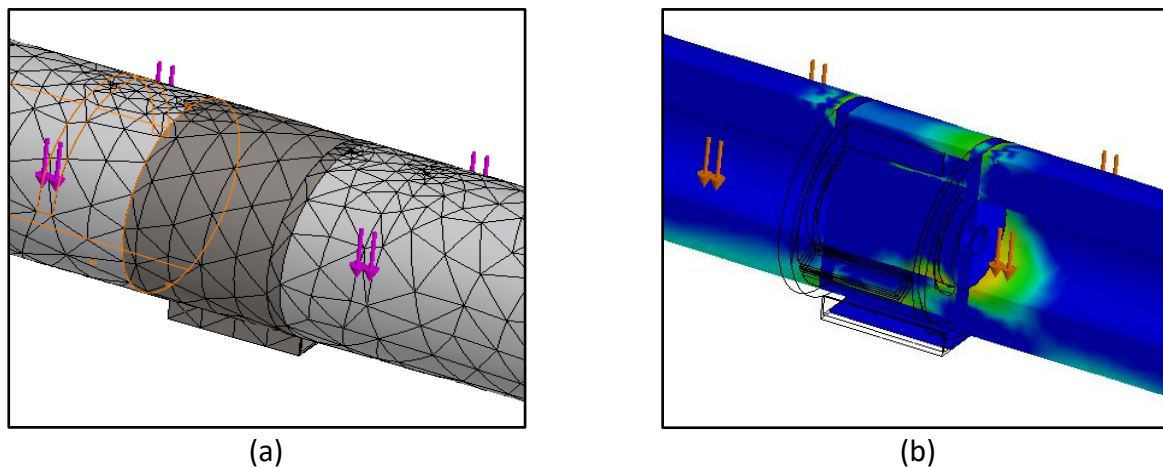

Figure 13: 400 mm YJACK model (a) finite element model and (b) finite element result

Conclusion

Based on the compression analysis of YJACK, it was found that the YJACK with empty space in it can withstand a load up to 1,400 kN. As the load increased more than 1,400 kN, the safety factor was decreased lower than 1. However, this can be solved by applying a concrete inside the empty space of YJACK as in actual application.

From the bending analysis, similar behavior of safety factors can be observed for diameter 300 and 400 mm of YJACK where the minimum values occurred at the junction between YJACK/Pile systems. Minimum safety factors are also observed at the bottom side of piles and it is predicted the disintegrations probably occurs at such locations.

In conclusion, the finite element modeling (FEM) analysis revealed that YJACK 300 and 400 mm are functionally and durable well to resist pile compression and bending during pile driving.



CORRELATION REPORT

BI-DIRECTIONAL PILE LOAD TESTING OF PILES

Validation Test of YJACK Bi-Directional Pile Load Test as the Alternative Pile Load Test Method Compared to Conventional Kentledge Method on Driven & Injection Concrete Piles.

Project Case Study: Kangsar, 2*YJACK Pile Tests (2*MLT)
Pile Driving System: Driven Piles on 2*Spun Concrete Pile 600mm, SC600Ø
CCGF Research Grant Milestone: Product Testing and Validating

PREPARED FOR:

RESEARCH GRANT:

Concept to Commercialization Gap Fund (CCGF)
High Impact Program 2 (HIP2)

GRANT MANAGER:

Agensi Inovasi Malaysia (AIM)
SME Corporation Malaysia (SME Corp)
PlaTCOM Ventures Sdn Bhd (PlaTCOM)

RESEARCH COLLABORATOR:

Universiti Tun Hussein Onn Malaysia (UTHM)
UTHM Commercial Sdn Bhd (UTHMC)

VALIDATION INSTITUTION:

Construction Research Institute Malaysia (CREAM)
Technical Opinion Program (TOP)

Prepared by:

Report Serial	Report No	Revision No	Issued Date
BDPLT-YJMY111	2	1	2017/APR/01



TABLE OF CONTENTS

	Page
COVER PAGE	1
TABLE OF CONTENTS	2
EXECUTIVE SUMMARY	3
VALIDATION BACKGROUND	4
VALIDATION PRODUCT – YJACK	4
VALIDATION OBJECTIVE	5
PILE DESIGN	5
YJACK MODEL	5
TERMINATION CRITERIA	6
PILE INSTALLATION	6
PILE LOCATION	6
INSTALLATION TERMINATION	7
INSTALLATION BEHAVIOR	7
YJACK TEST	8
YJACK VALIDATION RESULTS	9
YJACK VALIDATION CORRELATIONS	12
CORRELATION SUMMARY	15
VALIDATION CONCLUSION	16

- APPENDIX A1: Pile Installation Records
- APPENDIX A2: Bore Hole Records
- APPENDIX B: YJACK Bi-Directional Pile Load Test Loading Schedule
- APPENDIX C: YJACK Bi-Directional Pile Load Test Results using MLT
- APPENDIX D: Field Sheets
- APPENDIX E: Kentledge Pile Load Test Q-s Plots

- ATTACHMENT A: Standard Operating Procedure (SOP) in Constructing Q-s Plot from YJACK BD Pile Testing
- ATTACHMENT B: YJACK World Patent PCT/USA US 20170073922 A1
- ATTACHMENT C: Calibration Certificates



EXECUTIVE SUMMAY

The objectives of the tests were to validate the newly invented YJACK on driven concrete piles compared to conventional kentledge pile load test system in terms of:

- (1) the functionality, and
- (2) the accuracy

This YJACK validation correlation tests were performed at Project Case Study at Kangsar on 2016/JUN/02-08 with 2*NOS YJACK pile tests as following:

- Validation: maintained load tests (MLT) on Test Pile # FG-19(5) & G-21(5) to test load 4,000kN

The following is the summary of the correlation results obtained from Correlation Study.

Correlation Method # 1

The following is the correlation using load test settlement at working and test loads as the correlation base data:

Pile ID	FG-19(5)	G-21(5)
Loading Procedure	MLT	MLT
Average Accuracy	86.3%	92.8%
Accuracy Level *	High	High
Average Accuracy	89.6%	

* High if Accuracy \geq 80%; Moderate if 50% > Accuracy < 80%; Low if Accuracy \leq 50%

Correlation Method # 2

The following is the correlation using acceptable settlement at working and test loads as the correlation base data:

Pile ID	FG-19(5)	G-21(5)
Loading Procedure	MLT	MLT
Average Accuracy	96.3%	98.1%
Accuracy Level *	High	High
Average Accuracy	97.2%	

* High if Accuracy \geq 80%; Moderate if 50% > Accuracy < 80%; Low if Accuracy \leq 50%

The following is the validation conclusions for functionality and accuracy of the newly invented YJACK.

- (1) Validation for the functionality: the YJACKs are fully performed well in terms of functionality in installation and testing.
- (2) Validation for the accuracy: the YJACKs are fully performed well in terms of accuracy in terms of ultimate (i.e. the load) and serviceability (i.e. settlement) design considerations.

VALIDATION BACKGROUND

PlatCOM Ventures Sdn Bhd is the national technology commercialization platform of Malaysia. It is a wholly-owned subsidiary company of Agensi Inovasi Malaysia (AIM) formed in collaboration with SME Corporation Malaysia (SME Corp) under one of its six High Impact Programmes (HIPs) in SME Master Plan 2012-2020.

PlatCOM Ventures has a mission: to turn the creative ideas of our inventors and entrepreneurs into successful products and services that change the world.

The model addresses the innovation gaps through a holistic and 'market-driven' approach in supporting innovation and industrial competitiveness. It is designed to remove market and financing barriers to innovation.

The program provides necessary support from 'concept to commercialization'. This is done through the provision of access to technical assistance, market intelligence, incubation facilities, testing facilities and other relevant services - all in a single platform.

VALIDATION PRODUCT – YJACK

The validation product is YJACK. It is a static pile load test method based on bi-directional principle. It is an alternative and economical method to conventional maintained load test using kentledge blocks or reaction piles methods.

This invention is by far the best compared to conventional method. The YJACK solves problems by:

- a. cost saving;
- b. time saving (from 10 days to 1 day in preparation);
- c. eco-friendly green and safe;
- d. suitable for all types of piles and test loads as well as offshore piles using autoYJACK.



YJACK Pile Test	
	
STATIC METHOD (CONVENTIONAL)	YJACK METHOD (INNOVATIVE)
Expensive	Economical
Slow and Tedious	Fast and Simple
Large Work Platform	Environmental Green
Limited Test Load	Unlimited Test Load
Not for Offshore Piles	For All Types of Piles
Dangerous	Safe



VALIDATION OBJECTIVE

The objectives of the tests were to validate the newly invented YJACK on driven concrete piles compared to conventional kentledge pile load test system in terms of:

- (1) the functionality, and
- (2) the accuracy

This YJACK validation correlation tests were performed at Project Case Study at Kangsar on 2016/JUN/02-08 with 2*NOS YJACK pile tests as following:

- Validation: maintained load tests (MLT) on Test Pile # FG-19(5) & G-21(5) to test load 4,000kN

PILE DESIGN

The Test Piles have the following pile design information based on piling record:

Pile ID	FG-19(5)	G-21(5)
Pile Type	Spun Concrete	Spun Concrete
Pile Grade	Grade 80/Class B	Grade 80/Class B
Pile Size (mm)	600Ø	600Ø
Pile Area (cm ²)	1571	1571
Pile Make-Up	0.3Y+9E+6E	0.3Y+9E+6E
Pile Length (m)	15.3	15.3
Working Load (kN)	2,000	2,000
Test Load (kN)	4,000	4,000

YJACK MODEL

Based on the pile design, the following YJACK selected:

Pile ID	FG-19(5)	G-21(5)
YCELL Model	3GYJ3D300	3GYJ3D300
YCELL Capacity (kN)	4,000	4,000
YCELL Area (mm ²)	67,500	67,500
YCELL Quantity (nos)	1	1
YJACK Capacity (kN)	4,000	4,000
YJACK Size (mm)	600	600
YJACK Stroke (mm)	80	80

YCELL: the single hydraulic unit prior to fabricate the YJACK

TERMINATION CRITERIA

All the Test Piles were installed by driving hammer with pile termination criteria “pile to set” (refer to pile driving criteria from the piling contractor).

PILE INSTALLATION

The design pile make-up was $0.3\text{YJACK}+9\text{E}+6\text{E} = 15.3\text{m}$ (toe to top), YJACK end bearing design. The base of the pile toe was installed with YJACK during the pile driving process.

The following were the site photos to illustrate the YJACK installation:



Step (1)



Step (2)



Step (3)



Step (4)

Step (1): Spliced the YJACK at the end bearing (i.e. 0m from pile toe)

Step (2): Pile positioning, check verticality and then continue driving

Step (3): Hydraulic hoses and telltales attached out and fixed along the pile body

Step (4): End of pile driving and completion of the YJACK installation

The details of the pile installations were shown in the piling record as shown in Appendix A1 (Pile Installation Record).



INSTALLATION TERMINATION

All the Test Piles were installed pile to set as following:

Pile ID	FG-19(5)	G-21(5)
Date Installed	2016/JUN/02	2016/JUN/08
Pile Depth (m)	14.8	14.8
Pile Set (mm/10b)	Driven Pile to Set	Driven Pile to Set

Subsequently, pile tests were carried out as described in YJACK TEST Section.

INSTALLATION BEHAVIOR

The pile installation using driving hammer on the Test Piles has similar pile installation behavior like those working piles without YJACK. No abnormality installation behavior observed. This means that the YJACK has a good impedance so that the compressive forces can transmit from pile top to pile toe and effectively past thru the YJACK location without losses of the compressive forces.

The pile installation of Test Piles did not change the mode of piling practices. The Test Piles was installed like a normal pile (without YJACK). However, there were minor interruptions of pile installation for fixing the casing pipe outside the pile for every 1.0 – 1.5m pile penetration intervals.

In summary, the Test Piles have the followings installation behavior:

- No different in installation, just install the pile like a test pile without YJACK
- Minor interruptions in pile installation due to fixing of casing pipe
- The YJACK able to resist pile bending during installation
- The YJACK able to transmit compressive forces and has enough pile impedance

YJACK TEST

After waiting period of more than 2 months (without delay the contractor piling work plan), the Test Piles were subjected to static load pile test based on YJACK bi-directional method using a maintained load test loading procedure (MLT).

The pressure increment and loading schedule presented in Appendix B (YJACK Bi-Directional Pile Load Test Loading Schedule).

The displacements of the telltales were measured in every loading steps by using manual data recording on the field sheets.

The following were the site photos to illustrate the YJACK testing using bi-directional principle:



Step 1



Step 2



Step 3

Step 1: Reference beams setup (follow the conventional load test procedure)

Step 2: Load test setup ready, 4*dial gauges at pile top and 2*dial gauges for YJACK up/down

Step 3: Auto data recording using data logger (follow the conventional load test procedure)

YJACK VALIDATION RESULTS

The YJACK test results using static maintained load test (MLT) method were presented in Appendix C (YJACK Bi-Directional Pile Load Test Results using MLT).

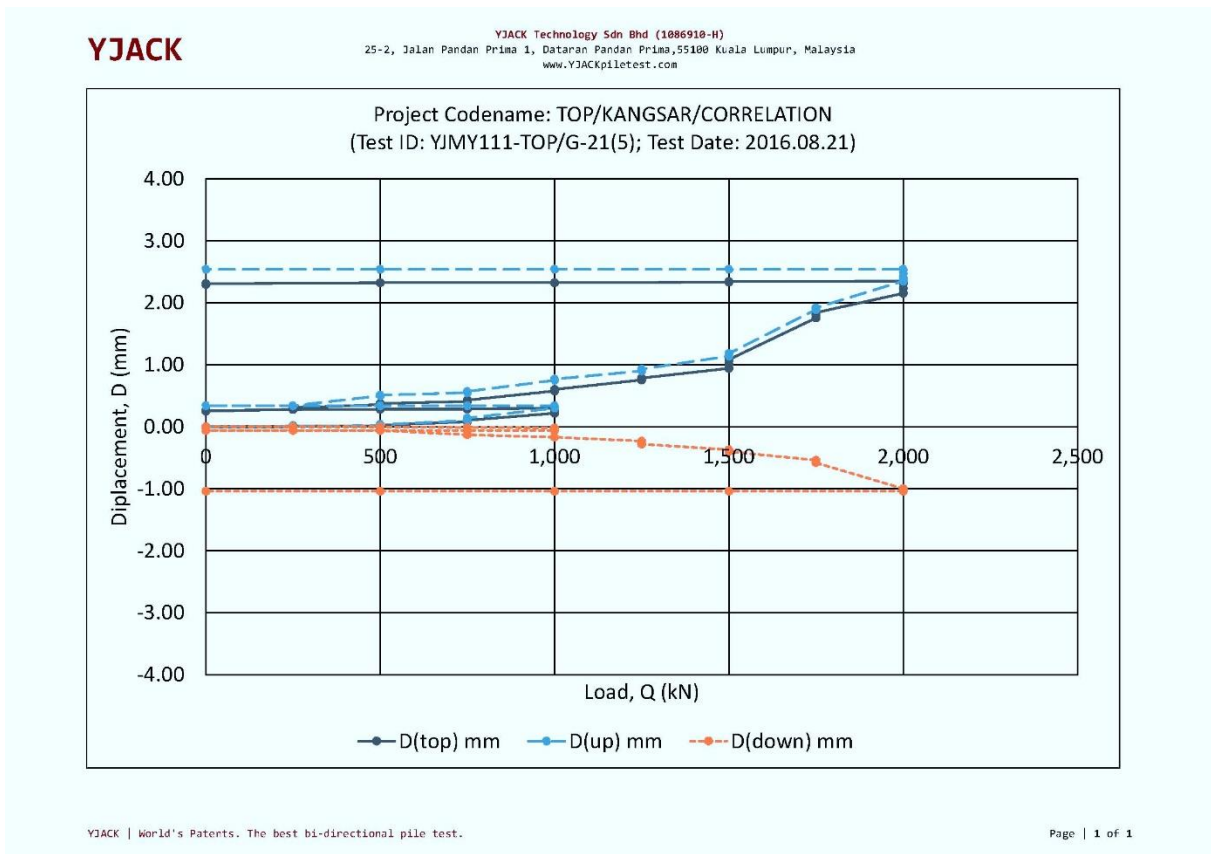
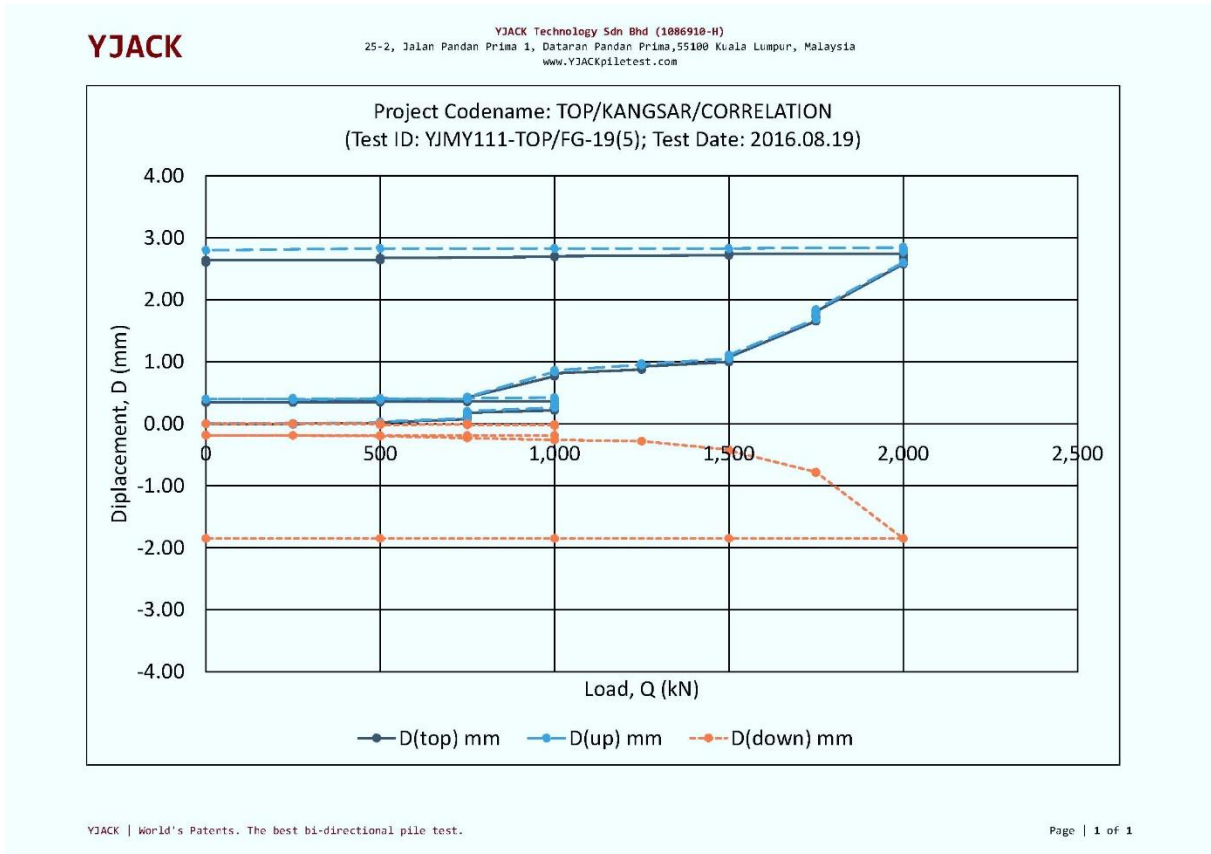

The following is the summary test results based on YJACK MLT Method:

Pile ID	FG-19(5)	G-21(5)
Skin Friction at Top Section (kN) *	2,000	2,000
Skin friction at Bottom Section + Base Bearing (kN) #	2,000	2,000
Total Pile Load Capacity in Full Section (kN)	4,000	4,000
Gap Opening after Removal Working Load 2000kN (mm)	0.40	0.34
Gap Opening after Removal Test Load 4000kN (mm)	2.80	2.54

* top skin friction not failure with applied load well maintained in 24 hours loading

base bearing not failure with permanent displacement < 30mm (= assumed 5% of pile diameter)

The following is the determination of the pile ultimate load by consideration of the tension over compression factor:

Pile ID	FG-19(5)	G-21(5)
Corrected Skin Friction at Top Section (kN) *	2,000/γ	2,000/γ
Corrected Skin Friction at Top Section (kN)	2,500	2,500
Corrected Total Pile Load Capacity in Full Section (kN)	4,500	4,500
Pile Weight at Top Section (kN) #	60	60
Ultimate Pile Load Capacity in Full Section (kN)	4,440	4,440
Accepted Ultimate Capacity in Full Section (kN)	> 4,000 (OK!)	> 4,000 (OK!)

* use tension over compression factor, γ = 0.8 for cohesive material

pile weight at pile top section = pile area x pile length at top section x pile density = about 60kN

The following is the summary test results based on top loaded Q-s Plot in accordance to Singapore Standard SS/CP4:

Pile ID	FG-19(5)	G-21(5)
Top-Loaded Pile Load Capacity (kN)	4,000	4,000
Top-Loaded Settlement at Working Load 300kN (mm)	2.9	2.0
Top-Loaded Settlement at Test Load 600kN (mm)	7.5	7.3

The following is the test acceptance in accordance to Malaysian JKR Specifications JKR/20800 (2014):

Pile ID	FG-19(5)	G-21(5)
Accepted Top-Loaded Pile Load Capacity (kN)	> 4,000 (OK!)	> 4,000 (OK!)
Accepted Top-Loaded Settlement at Working Load (mm)	< 12.5 (OK!)	< 12.5 (OK!)
Accepted Top-Loaded Settlement at Test Load (mm)	< 38.0 (OK!)	< 38.0 (OK!)
Accepted Residual Settlement *	< 6.5 (OK!)	< 6.5 (OK!)

* Pile-soil interaction of residual settlement assumed to be similar to gap opening after removal working load.



Test Comments:

- the YJACK gap opening after removal of the working load is very small, this small gap opening equivalent to residual settlement in conventional maintained load test with the pile head almost fully rebound
- the ultimate load of 4,440kN is deemed to be conservative
- it is recommended to do pile restrike to close the such a small gap opening of 2.54 – 2.80mm, to utilize the test piles as working piles



YJACK VALIDATION CORRELATIONS

All the Test Piles were tested by using kentledge method and YJACK method based on maintained load test (MLT) procedure.

The MLT load tests were carried out by kentledge followed by YJACK method on the same piles as follows:

Pile ID	FG-19(5)	G-21(5)
Kentledge Test	2016/JUN/08	2016/JUN/15
YJACK Test	2016/AUG/19	2016/AUG/21

The kentledge load tests were performed by using the conventional concrete blocks as the reaction system.

The correlation results are shown in following pages.

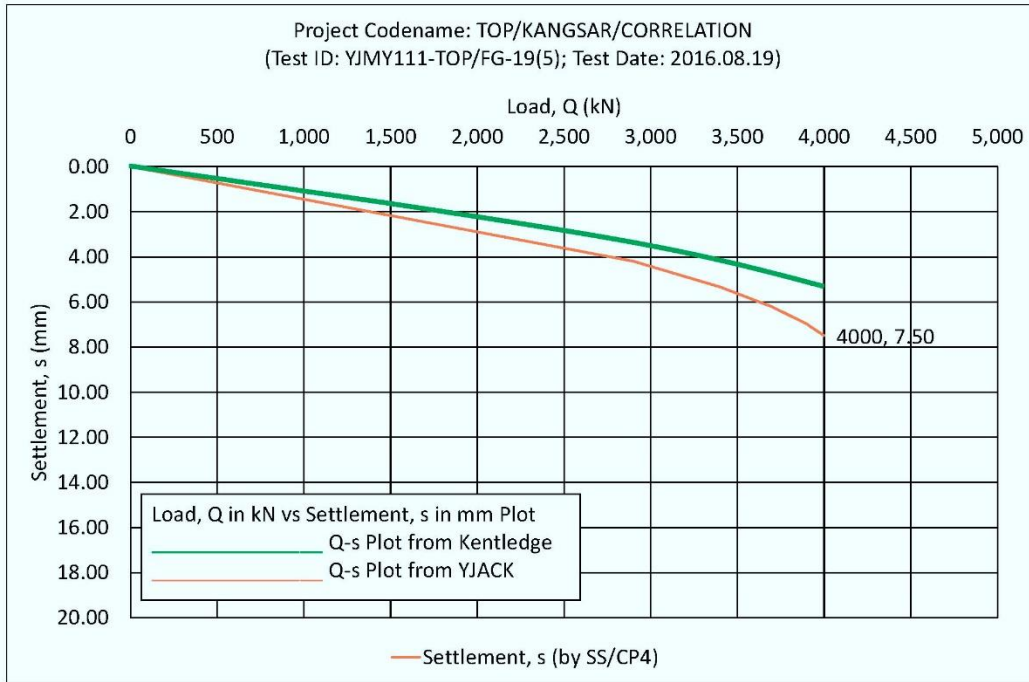

Correlation Method # 1

The following is the correlation using MLT settlement at working and test loads as the correlation base data:

Correlation Data Point	Working Load *	Settlement At 2,000kN	Test Load *	Settlement At 4,000kN
Kentledge Method	2,000	2.2	4,000	5.2
YJACK Method	2,000	2.9	4,000	7.5
Percentage Error #	0.0%	24.1%	0.0%	30.7%
Average Accuracy	86.3%			

* The loads were measured by same pressure system. Both system have same loading accuracies.

Percentage Error = (measured - published) / published, in absolute values

Correlation Method # 2

The following is the correlation using acceptable settlement at working and test loads as the correlation base data:

Correlation Data Point	Working Load *	Settlement Limit 12.5	Test Load *	Settlement Limit 38.0
Kentledge Method	2,000	10.3	4,000	32.8
YJACK Method	2,000	9.6	4,000	30.5
Percentage Error #	0.0%	7.3%	0.0%	7.5%
Average Accuracy	96.3%			

* The loads were measured by same pressure system. Both system have same loading accuracies.

Percentage Error = (measured - published) / published, in absolute values

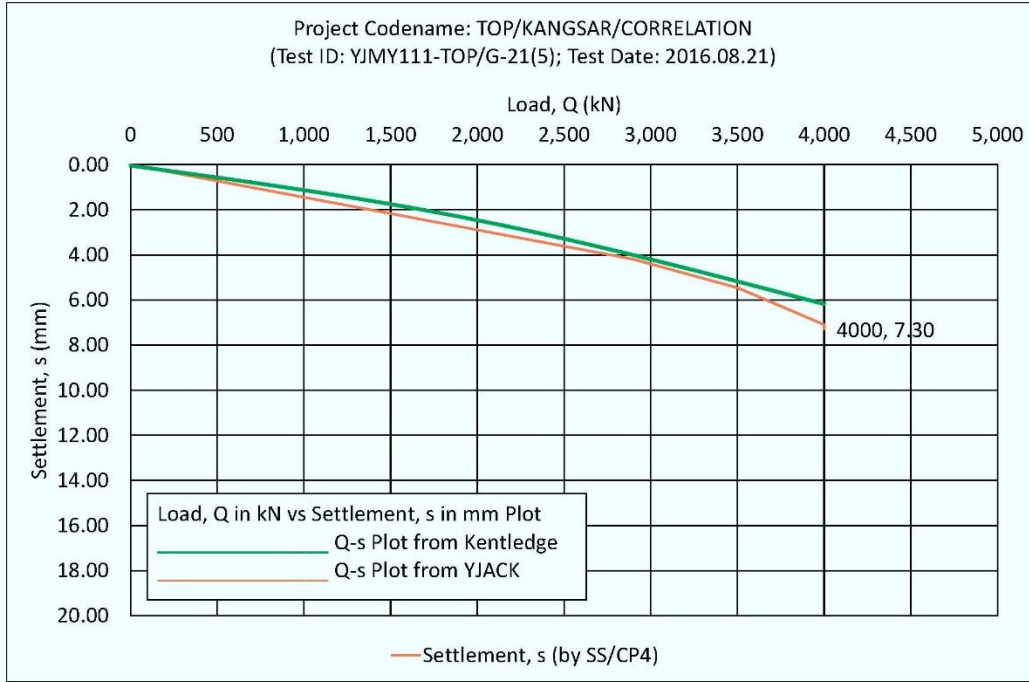

Correlation Method # 1

The following is the correlation using MLT settlement at working and test loads as the correlation base data:

Correlation Data Point	Working Load *	Settlement At 2,000kN	Test Load *	Settlement At 4,000kN
Kentledge Method	2,000	2.5	4,000	6.2
YJACK Method	2,000	2.9	4,000	7.3
Percentage Error #	0.0%	13.8%	0.0%	15.1%
Average Accuracy	92.8%			

* The loads were measured by same pressure system. Both system have same loading accuracies.

Percentage Error = (measured - published) / published, in absolute values

Correlation Method # 1

The following is the correlation using acceptable settlement at working and test loads as the correlation base data:

Correlation Data Point	Working Load *	Settlement Limit 12.5	Test Load *	Settlement Limit 38.0
Kentledge Method	2,000	10.0	4,000	31.8
YJACK Method	2,000	9.6	4,000	30.7
Percentage Error #	0.0%	4.2%	0.0%	3.6%
Average Accuracy	98.1%			

* The loads were measured by same pressure system. Both system have same loading accuracies.

Percentage Error = (measured - published) / published, in absolute values



CORRELARION SUMMARY

The following is the summary of the correlation results obtained from Correlation Phase 1 and Phase 2.

Correlation Method # 1

The following is the correlation using load test settlement at working and test loads as the correlation base data:

Pile ID	FG-19(5)	G-21(5)
Loading Procedure	MLT	MLT
Average Accuracy	86.3%	92.8%
Accuracy Level *	High	High
Average Accuracy	89.6%	

* High if Accuracy \geq 80%; Moderate if 50% > Accuracy < 80%; Low if Accuracy \leq 50%

Correlation Method # 2

The following is the correlation using acceptable settlement at working and test loads as the correlation base data:

Pile ID	FG-19(5)	G-21(5)
Loading Procedure	MLT	MLT
Average Accuracy	96.3%	98.1%
Accuracy Level *	High	High
Average Accuracy	97.2%	

* High if Accuracy \geq 80%; Moderate if 50% > Accuracy < 80%; Low if Accuracy \leq 50%



VALIDATION CONCLUSION

The following is the validation conclusions for functionality and accuracy of the newly invented YJACK.

(1) Validation for the functionality of the YJACK

The pile installation using driving hammer on the 2*NOS Test Piles has similar pile installation behavior like those working piles without YJACK. No abnormality installation behavior observed with the followings installation behavior:

- No different in installation, just install the pile like a test pile without YJACK
- Minor interruptions in pile installation due to fixing of casing pipe
- The YJACK able to resist pile bending during installation
- The YJACK able to transmit compressive forces and has enough pile impedance

The pile testing also demonstrated the YJACK can perform well under load pressurizations from 0 to 2,000 (working load) to 4,000 (test load). No any hydraulic jack interlocking observed during loading and unloading procedures.

In conclusion, the YJACKs are fully performed well in terms of functionality in installation and testing.

(2) Validation for the accuracy of the YJACK

The correlation summary on 2*NOS YJACK pile tests indicated high accuracy more than 85% with the following correlation studies:

- Validation: maintained load tests (MLT) on Test Pile # FG-19(5) & G-21(5) to test load 4,000kN

YJACK is a hydraulic jack system, the same to conventional load test which also using hydraulic jack in pressure loading measurements. Hence, both YJACK and kentledge loads were measured by the same pressure systems with same loading accuracies, i.e. 100%.

In the load-settlement behavior plots for kentledge and YJACK, both indicated similar patterns with accuracy range higher than 80%, in which this is deemed to be high level accuracy in correlation studies.

In conclusion, the YJACKs are fully performed well in terms of accuracy of ultimate (i.e. the load) and serviceability (i.e. settlement) design considerations.

APPENDIX A1

HAMMER DRIVEN PILING RECORD

PROJECT: Mydin K. Kangsar

DATE: 2-6-16

Size of Pile : <u>600mm</u>	Hammer Type : <u>9 ton</u>	Hammer Drop Height : <u>800 mm</u>
Pile Group : <u>F-6/19</u>	Supplied Pile Length : <u>9S + 6E</u>	Pile Combination :
Pile No : <u>(5)</u>	Penetration : <u>14.8m</u>	Final Set : <u>7mm</u>
Pile Frame :		No. of Pile Joints :

Penetration (M)	No. of Blow	Penetration (M)	No. of Blow	Penetration (M)	No. of Blow	Penetration (M)	No. of Blow	REMARKS
0.0-0.5	5	15.0-15.5		30.0-30.5		45.0-45.5		
0.5-1.0	7	15.5-16.0		30.5-31.0		45.5-46.0		
1.0-1.5	10	16.0-16.5		31.0-31.5		46		
1.5-2.0	10	16.5-17.0		31.5-32.0		46		
2.0-2.5	11	17.0-17.5		32.0-32.5		47		
2.5-3.0	10	17.5-18.0		32.5-33.0		47		
3.0-3.5	12	18.0-18.5		33.0-33.5		48		
3.5-4.0	12	18.5-19.0		33.5-34.0		48		
4.0-4.5	12	19.0-19.5		34.0-34.5		48		
4.5-5.0	14	19.5-20.0		34.5-35.0		48		
5.0-5.5	15	20.0-20.5		35.0-35.5		50		
5.5-6.0	17	20.5-21.0		35.5-36.0		50		
6.0-6.5	19	21.0-21.5		36.0-36.5		50		
6.5-7.0	19	21.5-22.0		36.5-37.0		50		
7.0-7.5	18	22.0-22.5		37.0-37.5		50		
7.5-8.0	18	22.5-23.0		37.5-38.0		50		
8.0-8.5	20	23.0-23.5		38.0-38.5		50		
8.5-9.0	20	23.5-24.0		38.5-39.0		50		
9.0-9.5	22	24.0-24.5		39.0-39.5		50		
9.5-10.0	22	24.5-25.0		39.5-40.0		50		
10.0-10.5	23	25.0-25.5		40.0-40.5		50		
10.5-11.0	26	25.5-26.0		40.5-41.0		50		
11.0-11.5	26	26.0-26.5		41.0-41.5		50		
11.5-12.0	75	26.5-27.0		41.5-42.0		50		
12.0-12.5	75	27.0-27.5		42.0-42.5		50		
12.5-13.0	78	27.5-28.0		42.5-43.0		57.5-58.0		
13.0-13.5	78	28.0-28.5		43.0-43.5		58.0-58.5		
13.5-14.0	80	28.5-29.0		43.5-44.0		58.5-59.0		
14.0-14.5	90	29.0-29.5		44.0-44.5		59.0-59.5		
14.5-15.0	95	29.5-30.0		44.5-45.0		59.5-60.0		

[Handwritten signatures and notes]
7mm
6mm

Client' Rep

Set.

14.10.2016

Pile Level - 64 - 987

HAMMER DRIVEN PILING RECORD

PROJECT: Mydin K. Kangsar

DATE: 2-8-16

Size of Pile : <u>600 mm</u>	Hammer Type : <u>9 ton</u>	Hammer Drop Height : <u>0 mm</u>
Pile Group : <u>G/21</u>	Supplied Pile Length : <u>95 + 6E</u>	Pile Combination :
Pile No : <u>(5)</u>	Penetration : <u>14.8 m</u>	Final Set : <u>4.44</u>
Pile Frame :		No. of Pile Joints :

Penetration (M)	No. of Blow	Penetration (M)	No. of Blow	Penetration (M)	No. of Blow	Penetration (M)	No. of Blow
0.0-0.5	2	15.0-15.5		30.0-30.5		45.0-45.5	
0.5-1.0	7	15.5-16.0		30.5-31.0		45.5-46.0	
1.0-1.5	11	16.0-16.5		31.0-31.5		46.0-46.5	
1.5-2.0	14	16.5-17.0		31.5-32.0		46.5-47.0	
2.0-2.5	15	17.0-17.5		32.0-32.5			
2.5-3.0	15	17.5-18.0		32.5-33.0			
3.0-3.5	18	18.0-18.5		33.0-33.5			
3.5-4.0	24	18.5-19.0		33.5-34.0			
4.0-4.5	30	19.0-19.5		34.0-34.5			
4.5-5.0	36	19.5-20.0		34.5-35.0			
5.0-5.5	36	20.0-20.5		35.0-35.5			
5.5-6.0	40	20.5-21.0		35.5-36.0			
6.0-6.5	45	21.0-21.5		36.0-36.5			
6.5-7.0	60	21.5-22.0		36.5-37.0			
7.0-7.5	62	22.0-22.5		37.0-37.5			
7.5-8.0	60	22.5-23.0		37.5-38.0			
8.0-8.5	65	23.0-23.5		38.0-38.5			
8.5-9.0	70	23.5-24.0		38.5-39.0	5		
9.0-9.5	71	24.0-24.5		39.0-39.5	5		
9.5-10.0	70	24.5-25.0		39.5-40.0	54		
10.0-10.5	71	25.0-25.5		40.0-40.5	55		
10.5-11.0	74	25.5-26.0		40.5-41.0	55		
11.0-11.5	80	26.0-26.5		41.0-41.5	56		
11.5-12.0	82	26.5-27.0		41.5-42.0	56.5		
12.0-12.5	86	27.0-27.5		42.0-42.5	57.0		
12.5-13.0	88	27.5-28.0		42.5-43.0	57.5		
13.0-13.5	90	28.0-28.5		43.0-43.5	58.0		
13.5-14.0	92	28.5-29.0		43.5-44.0	58.5-59.0		
14.0-14.5	94	29.0-29.5		44.0-44.5	59.0-59.5		
14.5-15.0	103	29.5-30.0		44.5-45.0	59.5-60.0		

REMARKS

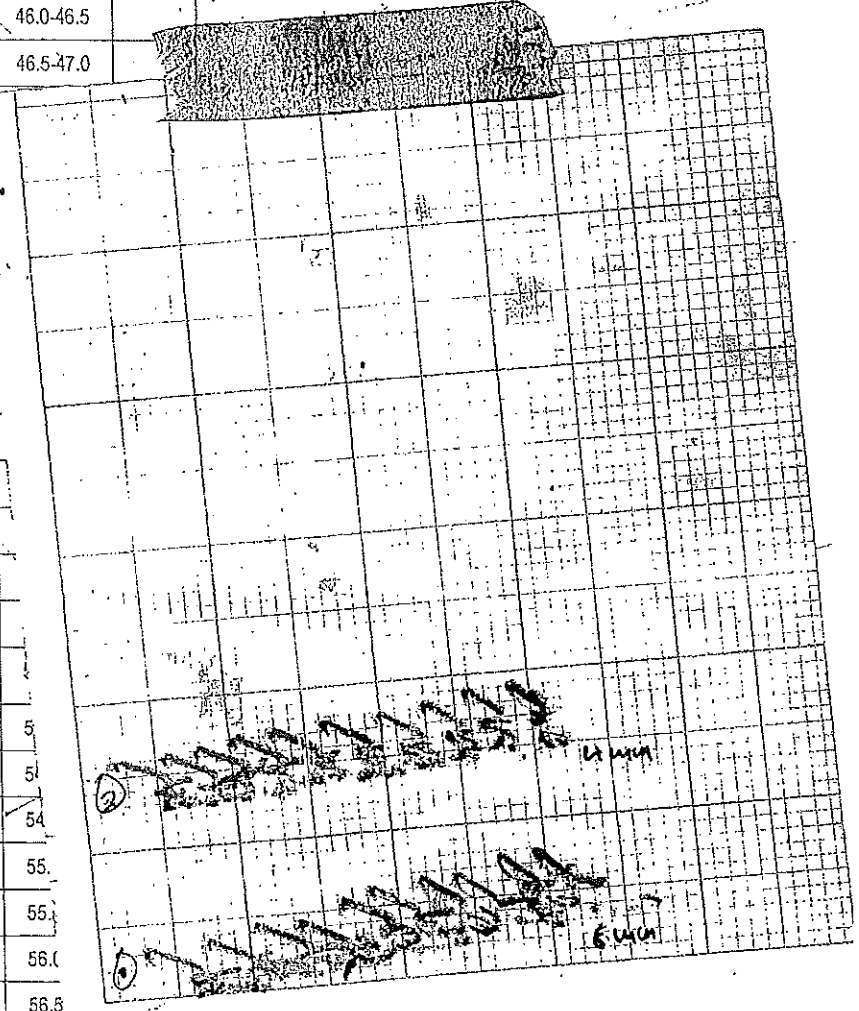

Set

1.1.



Client Rep

APPENDIX A2

Bore-Hole Records / SI Report

Thick documents. Will be furnished upon request.

APPENDIX B



Bi-Directional Pile Load Test (BDPLT), Reaction System: YJACK System, Test Procedure: Maintained Load Test (MLT)
 Loading Schedule Table Sheet for SC600; Test Load 4,000kN

Project Name: Bi-directional Test at Kangsar

Test Pile Data

YJACK Data

Pile ID:	YJACK Test Pile (Spun Pile)	YCELL Model:	3GYJ3D300
Pile Size:	600 mm	YCELL Stroke:	80 mm
Work Load in F(BD):	2,000 kN	YCELL Capacity in F(BD):	4,000 kN
Test Load in F(BD):	4,000 kN	YCELL Effective Area:	67,500 mm ²
Safety Factor:	2.0 kN	YCELL Quantity:	1 NOS
Applied Working Load in F(1D):	1,000 kN	YJACK Capacity in F(BD):	4,000 kN
Applied Test Load in F(1D):	2,000 kN	YJACK Effective Area:	67,500 mm ²

BD: bi-rectional load; 1D: single or uni-directional load

Load Schedule Table for Maintain Load Testing using Bi-Directional Pile Load Test using YJACK							use γ value
Working Load (%)	Applied Load F(1D) (kN)	Pressure Reading (N/mm ²)	Pressure Reading (BAR)	Holding Time (min)*	Read Time (min)	Test Load F(BD) (kN)	Corrected Load (kN)
25	250.0	3.7	37.0	60	15	500	563
50	500.0	7.4	74.1	60	15	1,000	1,125
75	750.0	11.1	111.1	60	15	1,500	1,688
100	1,000.0	14.8	148.1	360	15 then 60	2,000	2,250
75	750.0	11.1	111.1	60	15	1,500	1,688
50	500.0	7.4	74.1	60	15	1,000	1,125
25	250.0	3.7	37.0	60	15	500	563
0	0.0	0.0	0.0	60	15	0	0
25	250.0	3.7	37.0	60	15	500	563
50	500.0	7.4	74.1	60	15	1,000	1,125
75	750.0	11.1	111.1	60	15	1,500	1,688
100	1,000.0	14.8	148.1	60	15	2,000	2,250
125	1,250.0	18.5	185.2	60	15	2,500	2,813
150	1,500.0	22.2	222.2	60	15	3,000	3,375
175	1,750.0	25.9	259.3	60	15	3,500	3,938
200	2,000.0	29.6	296.3	1440	15 then 60	4,000	4,500
150	1,500.0	22.2	222.2	60	15	3,000	3,375
100	1,000.0	14.8	148.1	60	15	2,000	2,250
50	500.0	7.4	74.1	60	15	1,000	1,125
0	0.0	0.0	0.0	60	15	0	0

* Settlement Rate: < 0.05mm/15mins or Holding Time: min 2 hours achieved

2880	test duration in minutes
48	test duration in hours

APPENDIX C

Project Codename: TOP/KANGSAR/CORRELATION
 (Test ID: YJMY111-TOP/FG-19(5); Test Date: 2016.08.19)

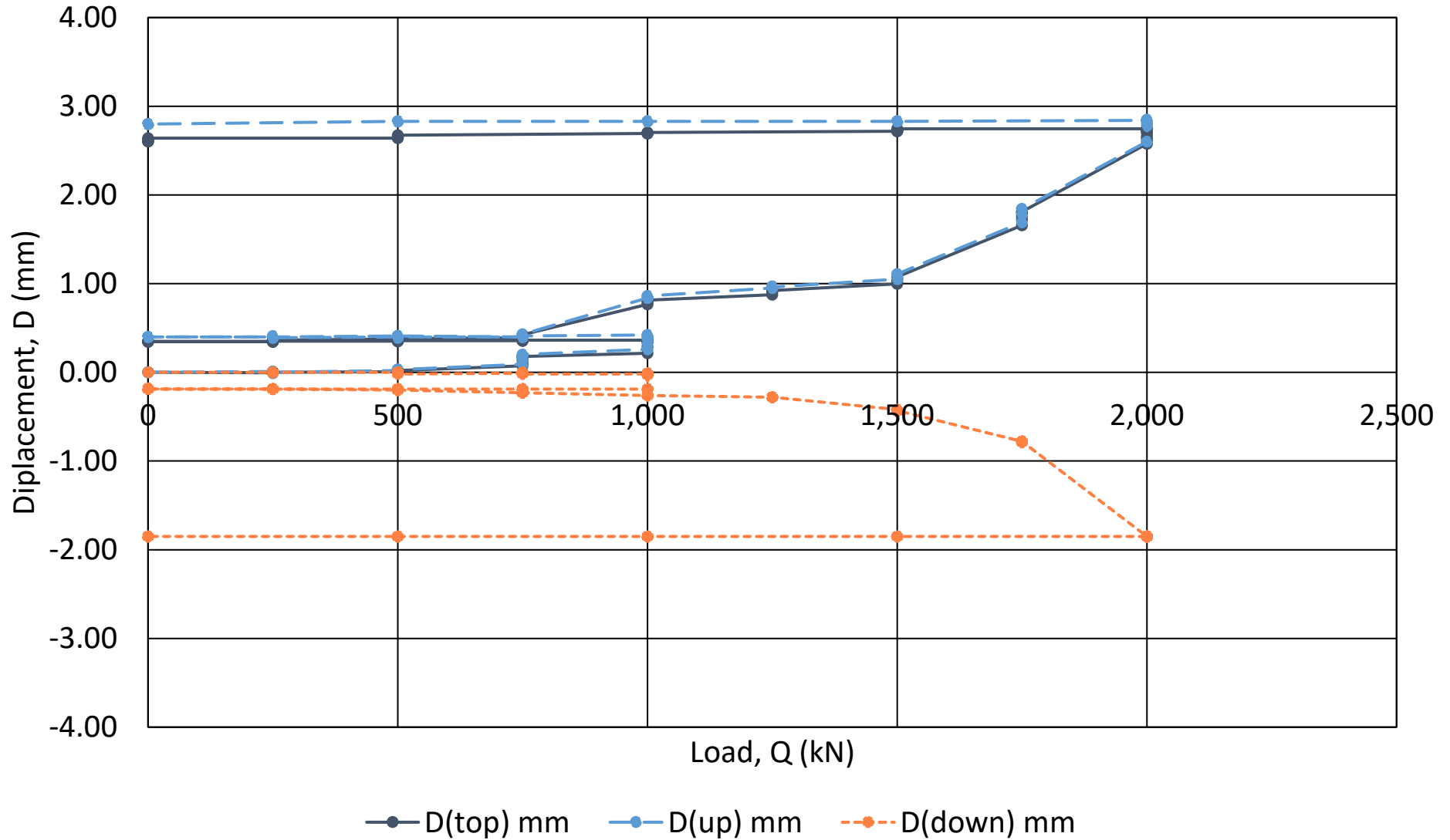

Project Codename: TOP/KANGSAR/CORRELATION
(Test ID: YJMY111-TOP/FG-19(5); Test Date: 2016.08.19)

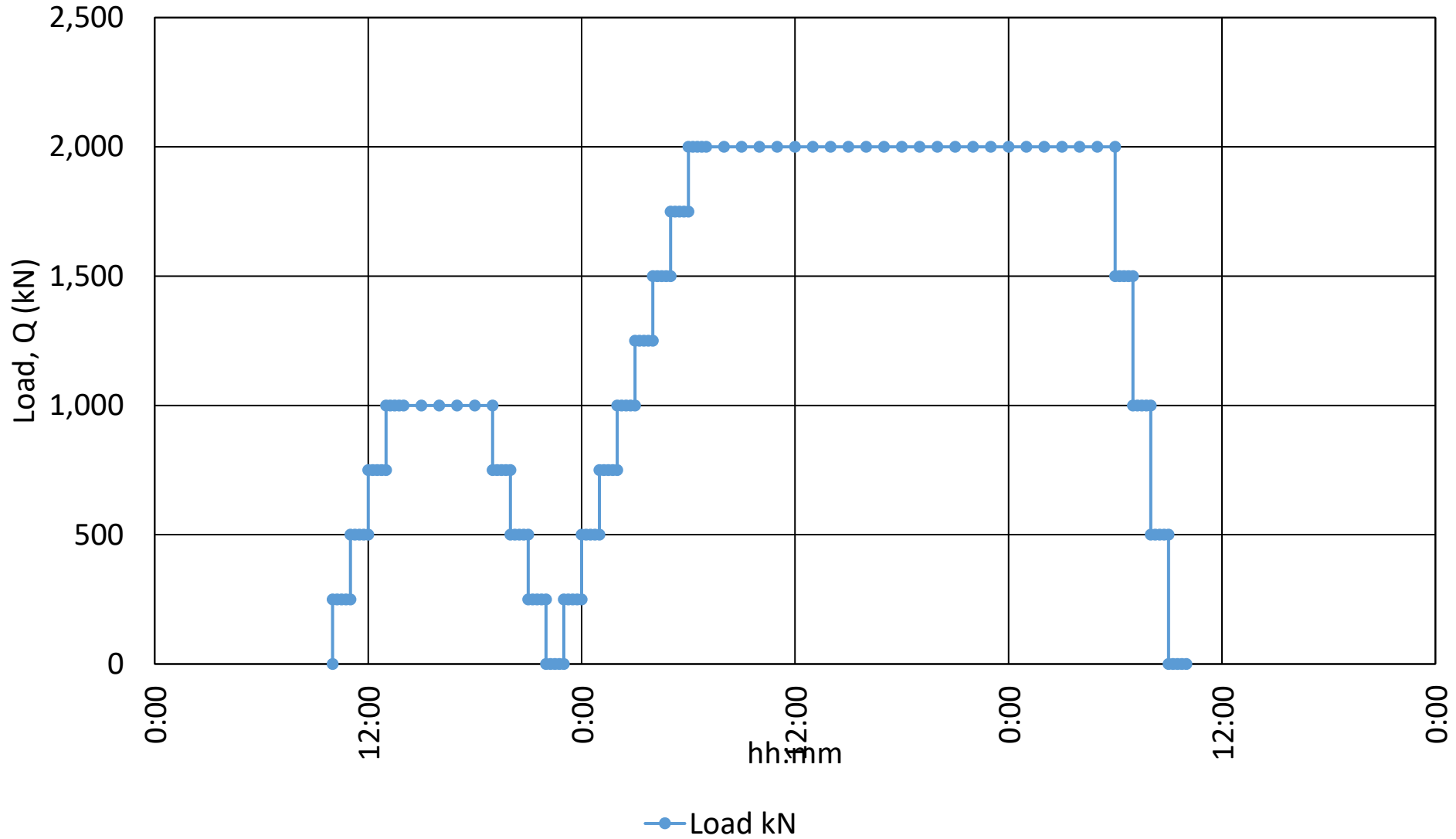

Project Codename: TOP/KANGSAR/CORRELATION
(Test ID: YJMY111-TOP/FG-19(5); Test Date: 2016.08.19)

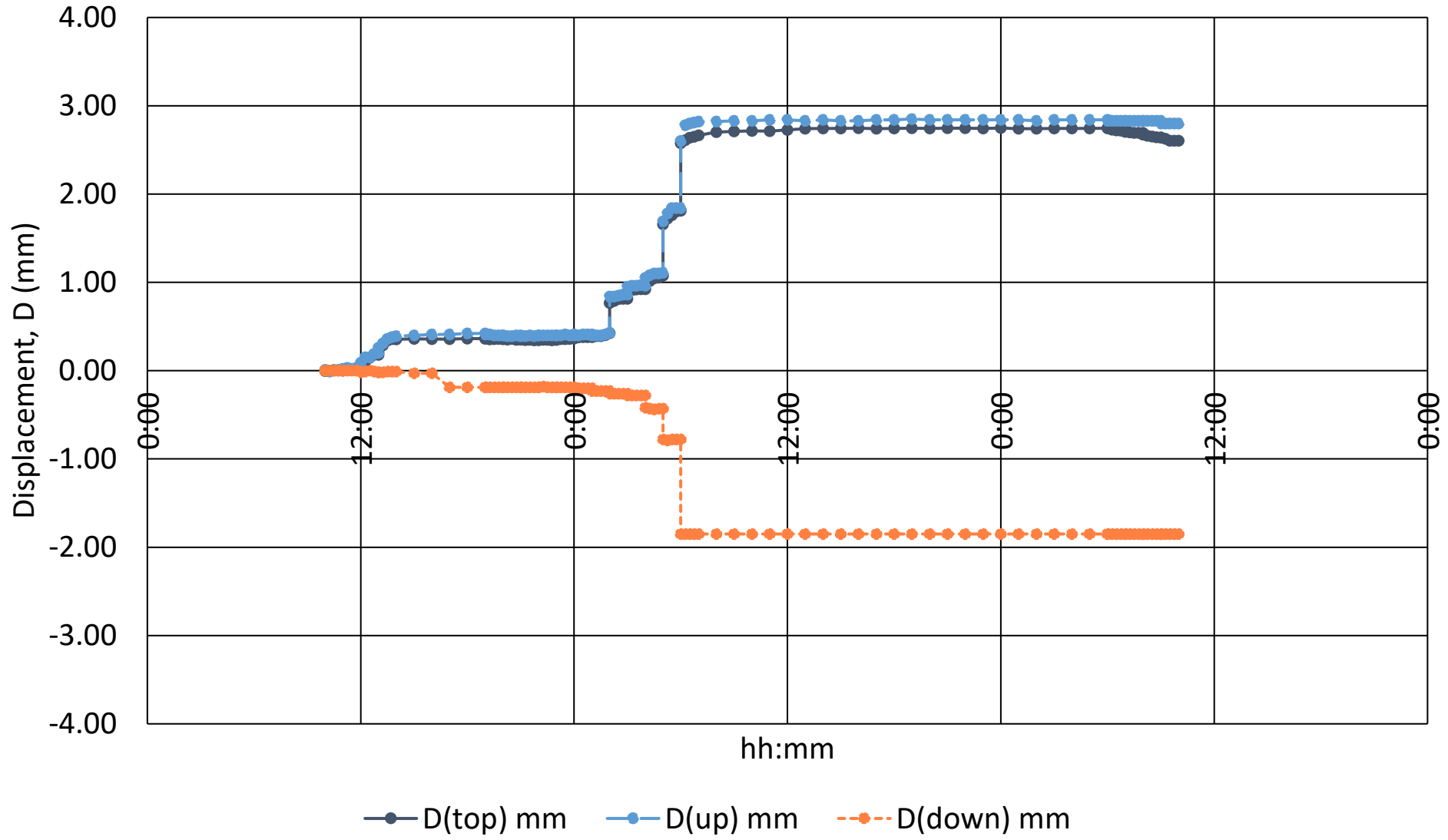

Project Codename: TOP/KANGSAR/CORRELATION
 (Test ID: YJMY111-TOP/FG-19(5); Test Date: 2016.08.19)

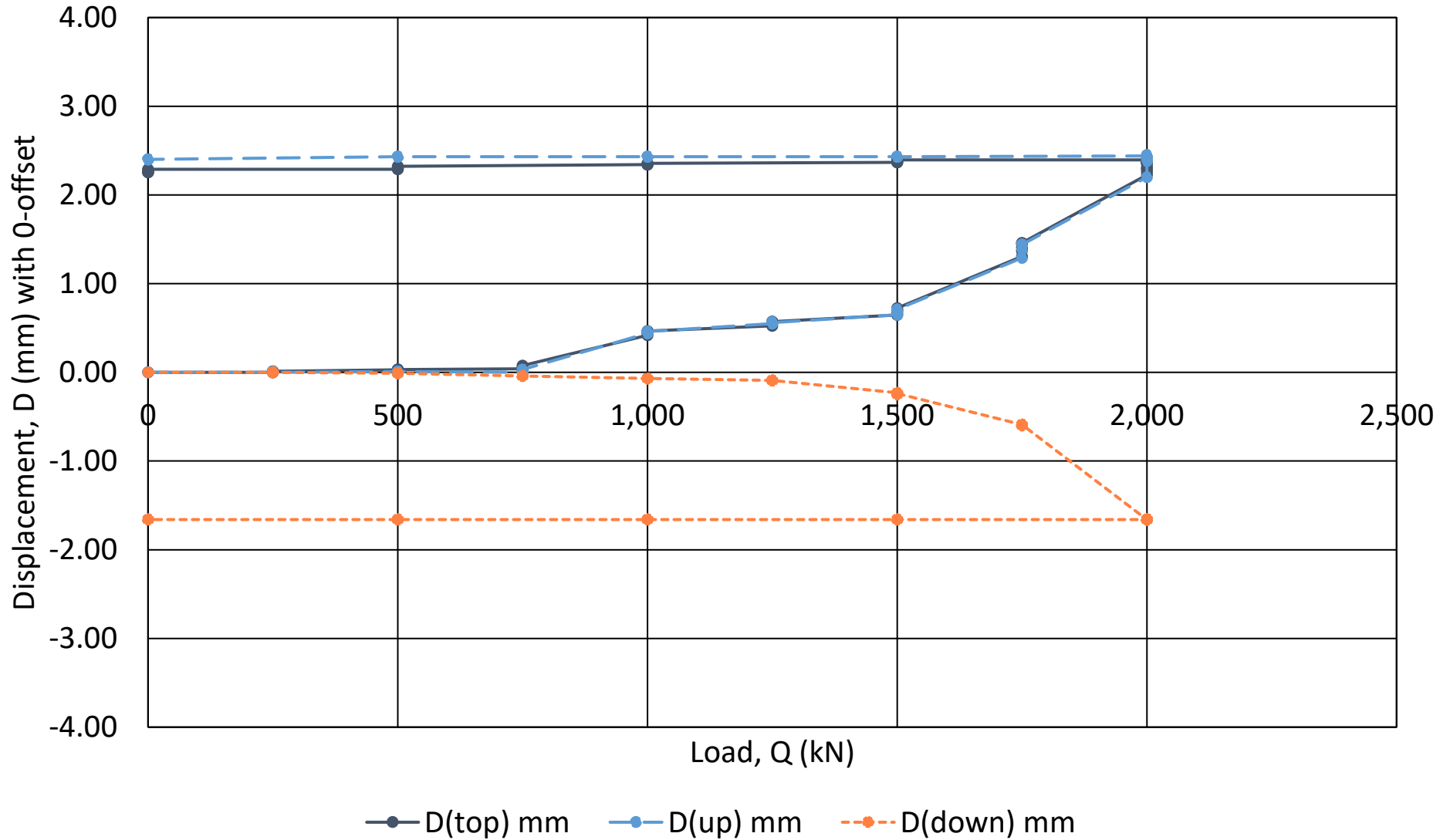

Project Codename: TOP/KANGSAR/CORRELATION
 (Test ID: YJMY111-TOP/FG-19(5); Test Date: 2016.08.19)

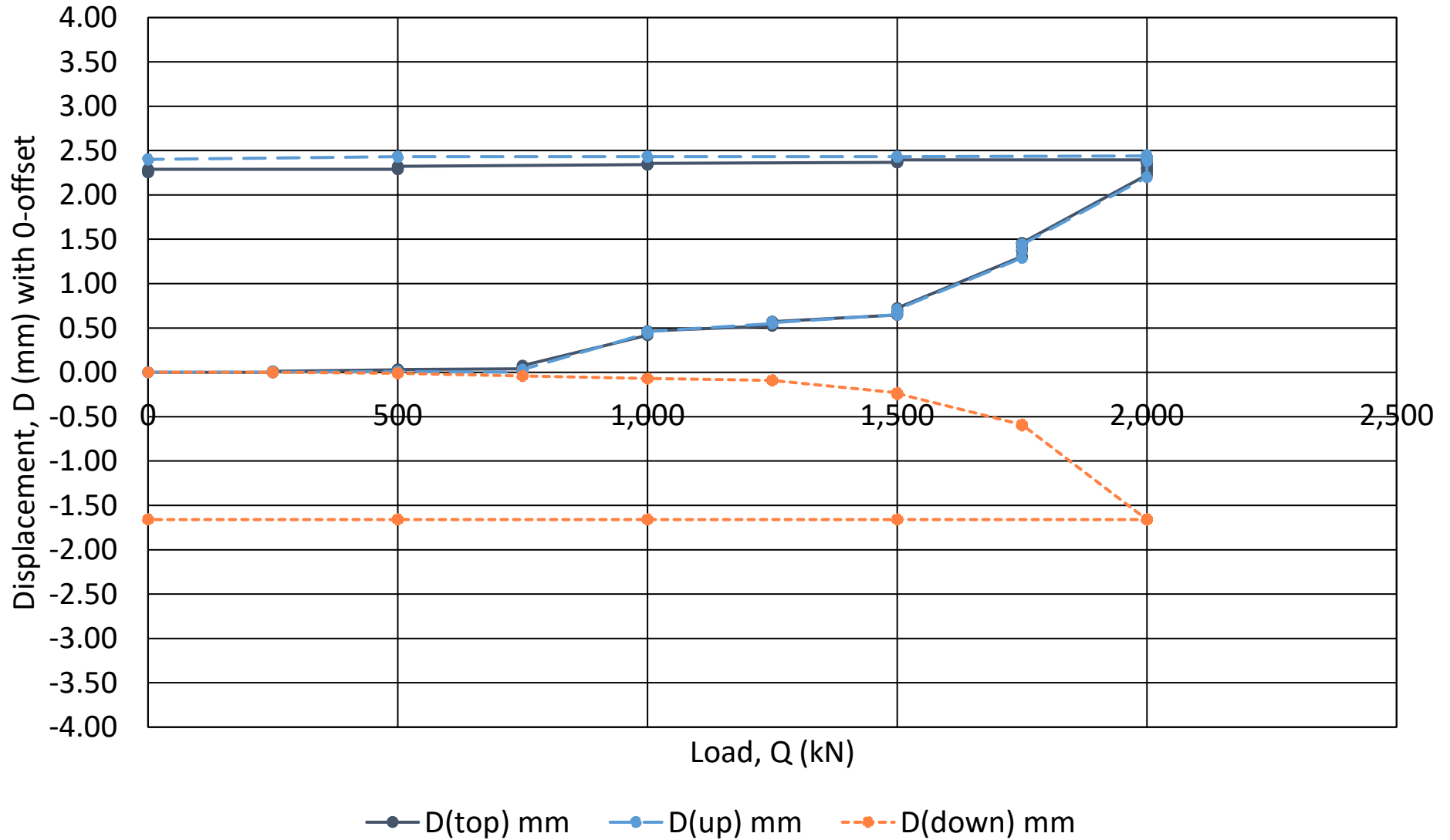

Project Codename: TOP/KANGSAR/CORRELATION
 (Test ID: YJMY111-TOP/FG-19(5); Test Date: 2016.08.19)

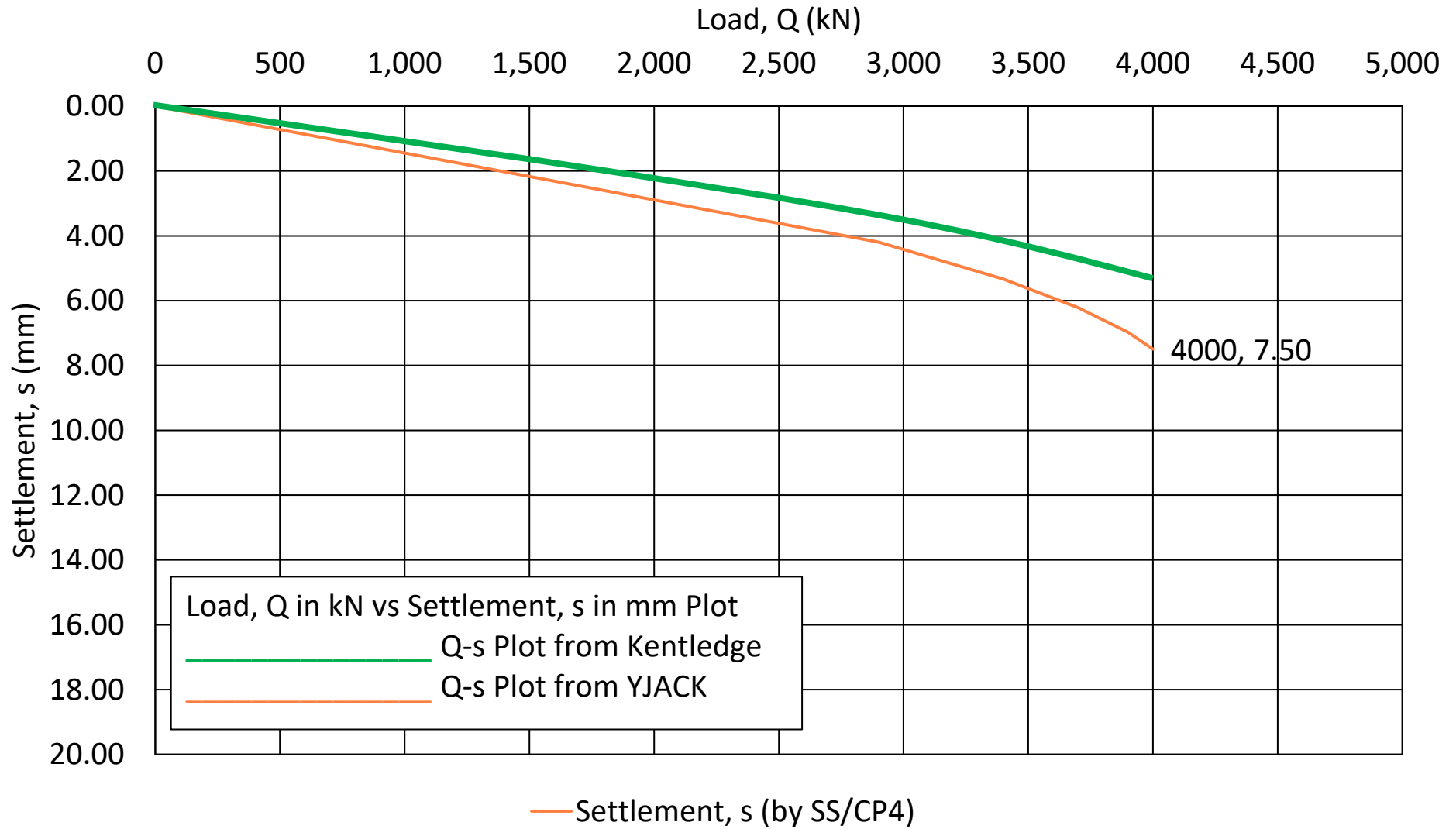

Project Codename: TOP/KANGSAR/CORRELATION
 (Test ID: YJMY111-TOP/G-21(5); Test Date: 2016.08.21)

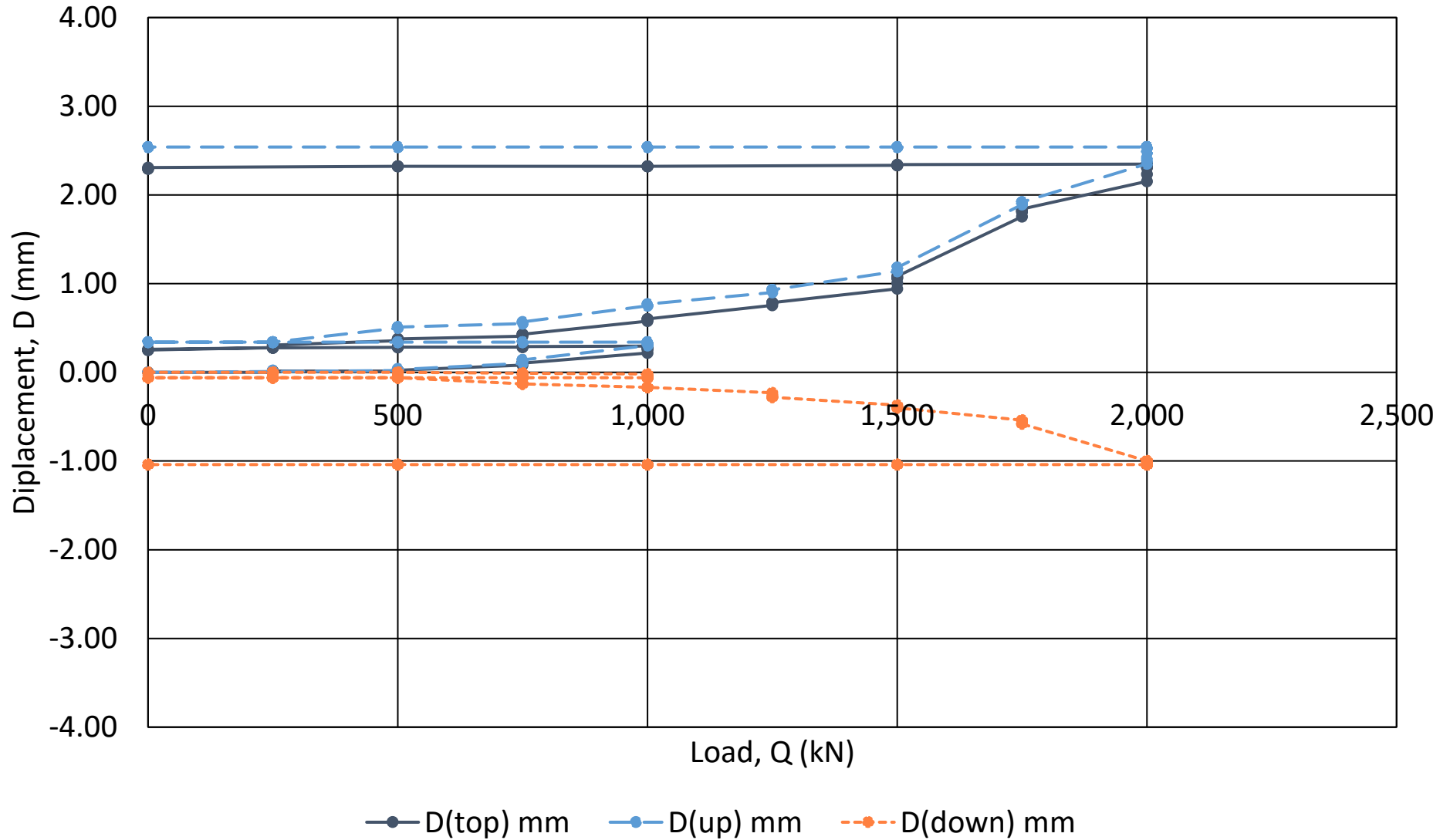

Project Codename: TOP/KANGSAR/CORRELATION
(Test ID: YJMY111-TOP/G-21(5); Test Date: 2016.08.21)

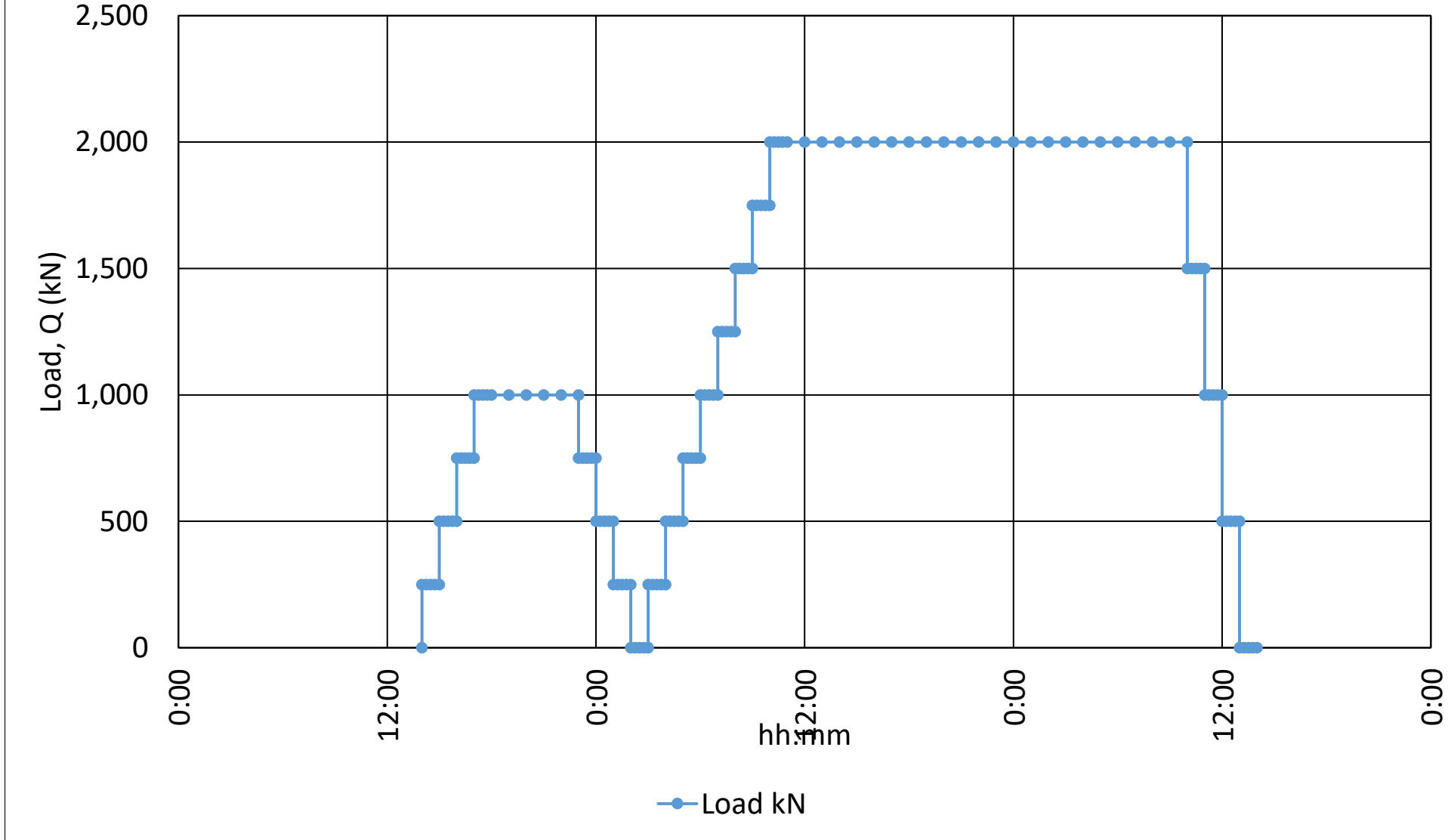

Project Codename: TOP/KANGSAR/CORRELATION
(Test ID: YJMY111-TOP/G-21(5); Test Date: 2016.08.21)

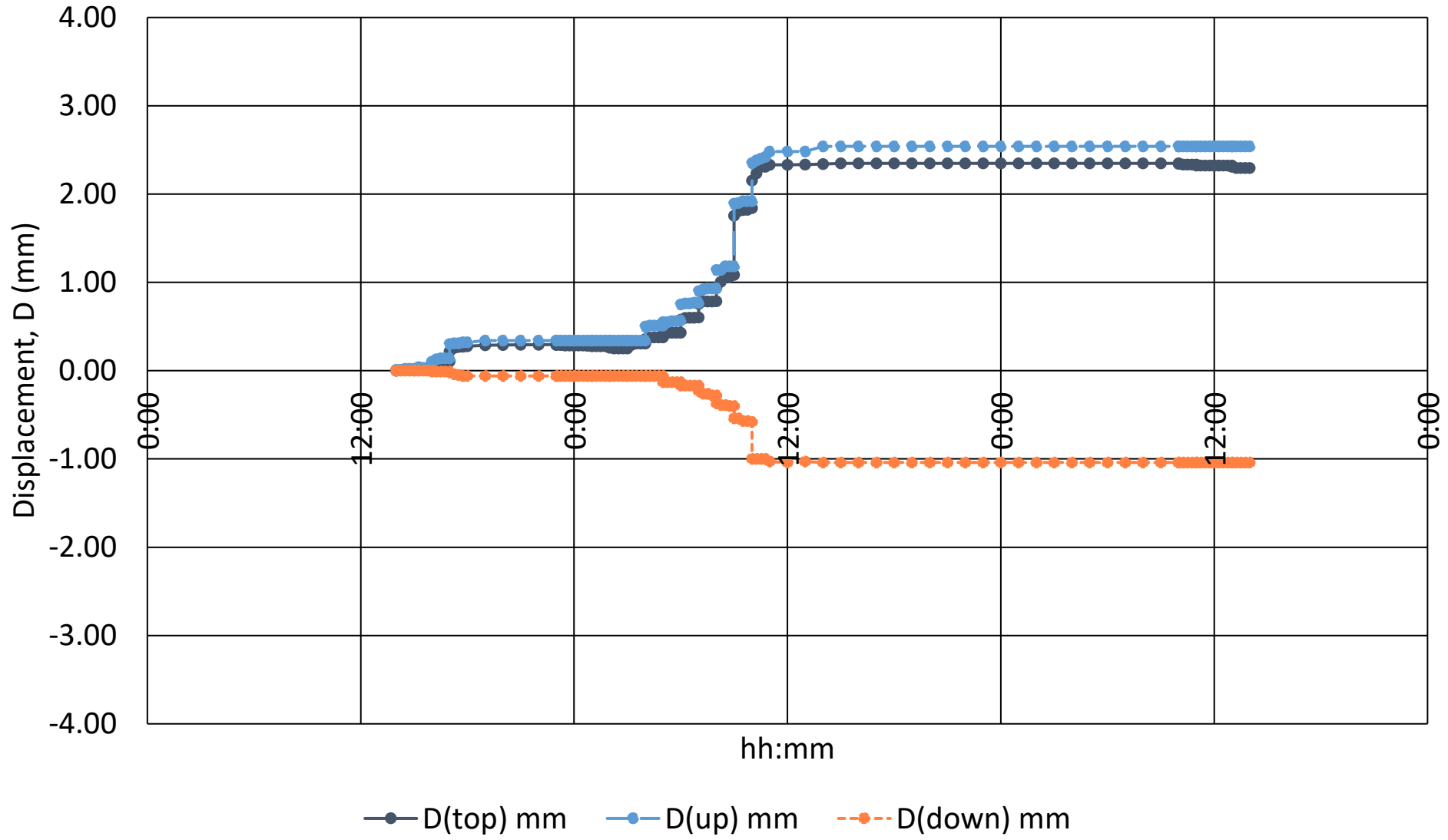

Project Codename: TOP/KANGSAR/CORRELATION
 (Test ID: YJMY111-TOP/G-21(5); Test Date: 2016.08.21)

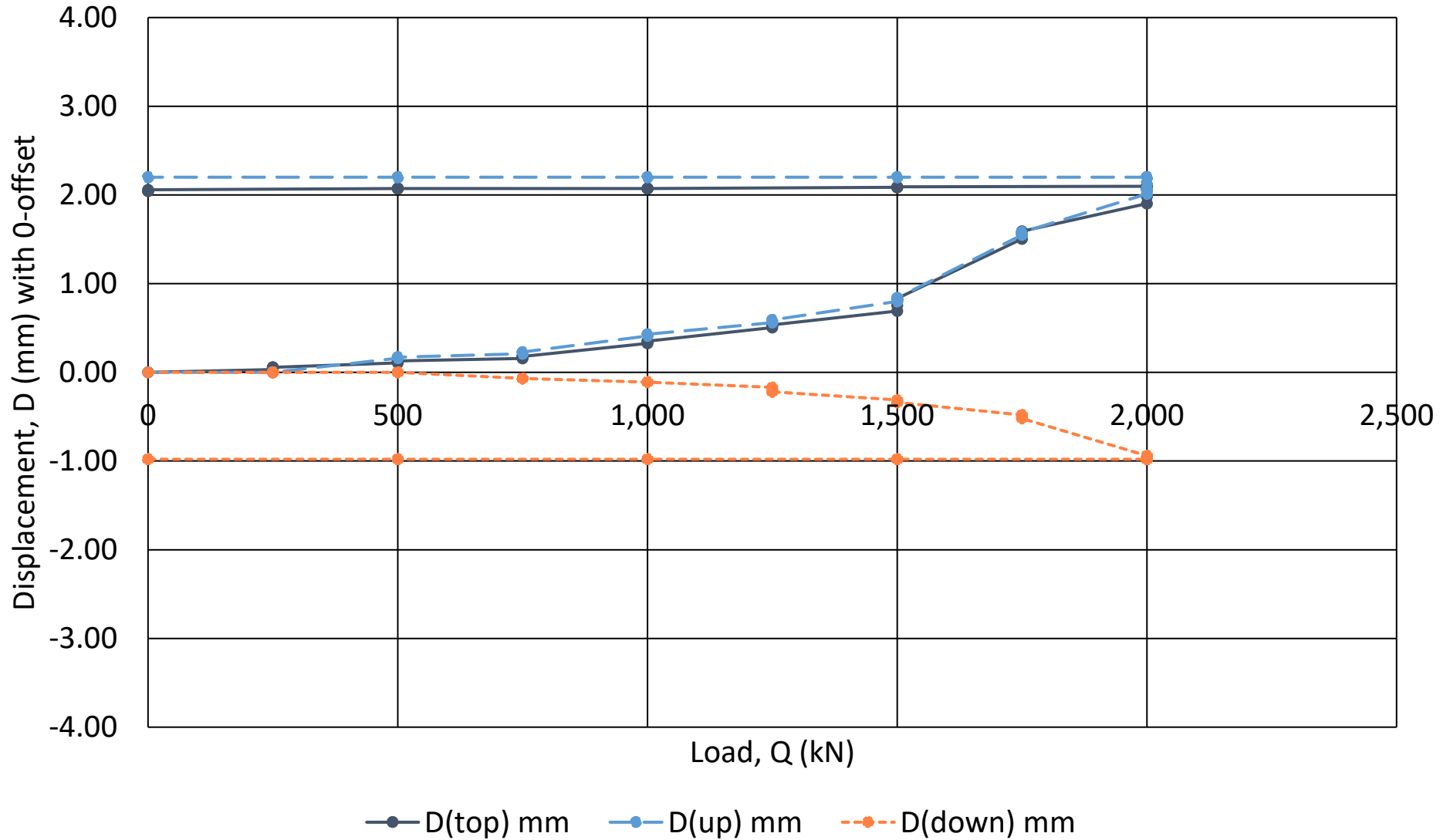

Project Codename: TOP/KANGSAR/CORRELATION
 (Test ID: YJMY111-TOP/G-21(5); Test Date: 2016.08.21)

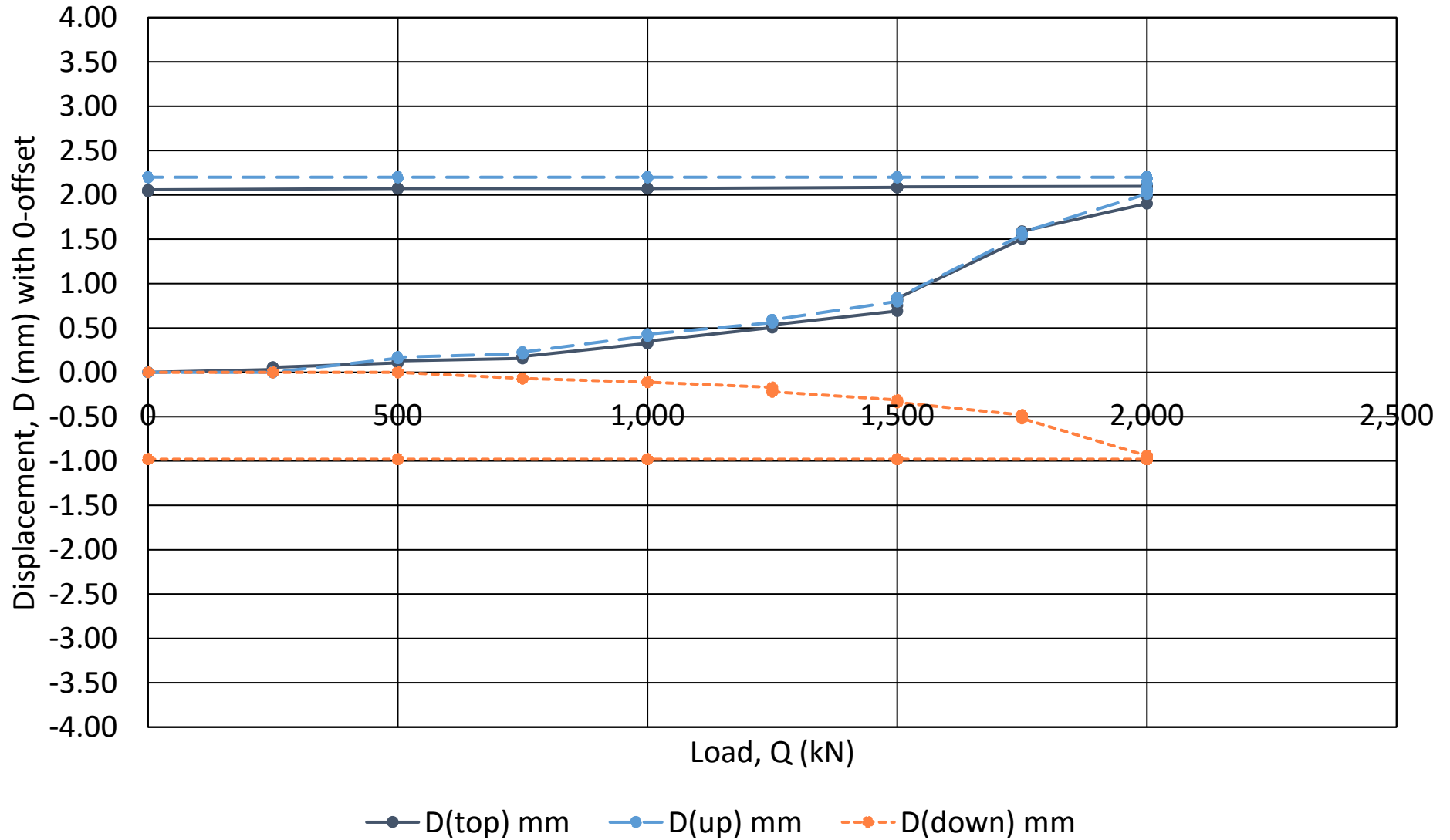

Project Codename: TOP/KANGSAR/CORRELATION
 (Test ID: YJMY111-TOP/G-21(5); Test Date: 2016.08.21)

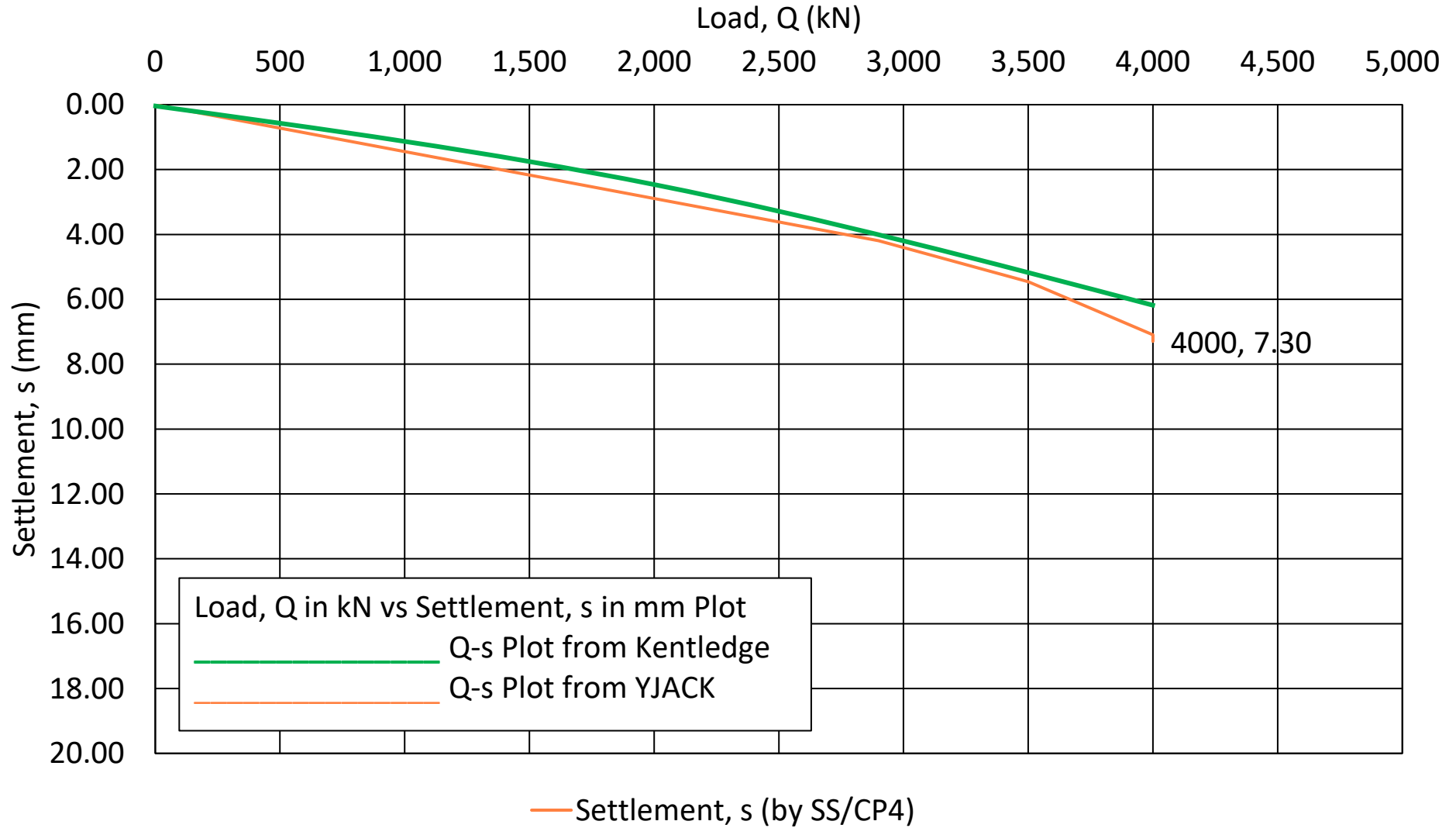

APPENDIX D

Field Sheets

Thick documents. Will be furnished upon request.

APPENDIX E

Project Codename:TOP/KANGSAR/CORRELATION
 (Test ID: FG-19(5) MLT; Test Date: 2016/06/08)

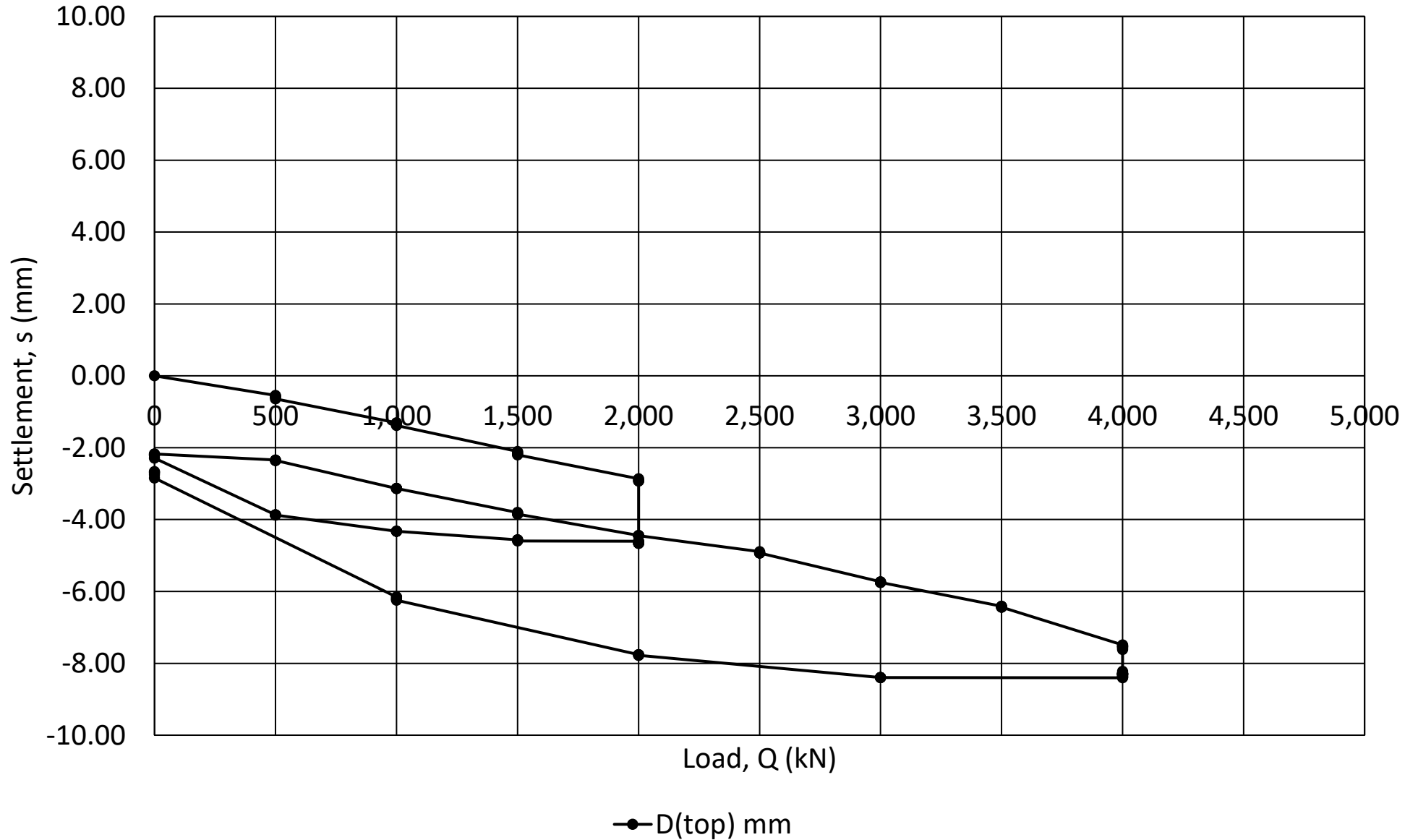

Project Codename:TOP/KANGSAR/CORRELATION
(Test ID: G-21(5) MLT; Test Date: 2016/06/15)

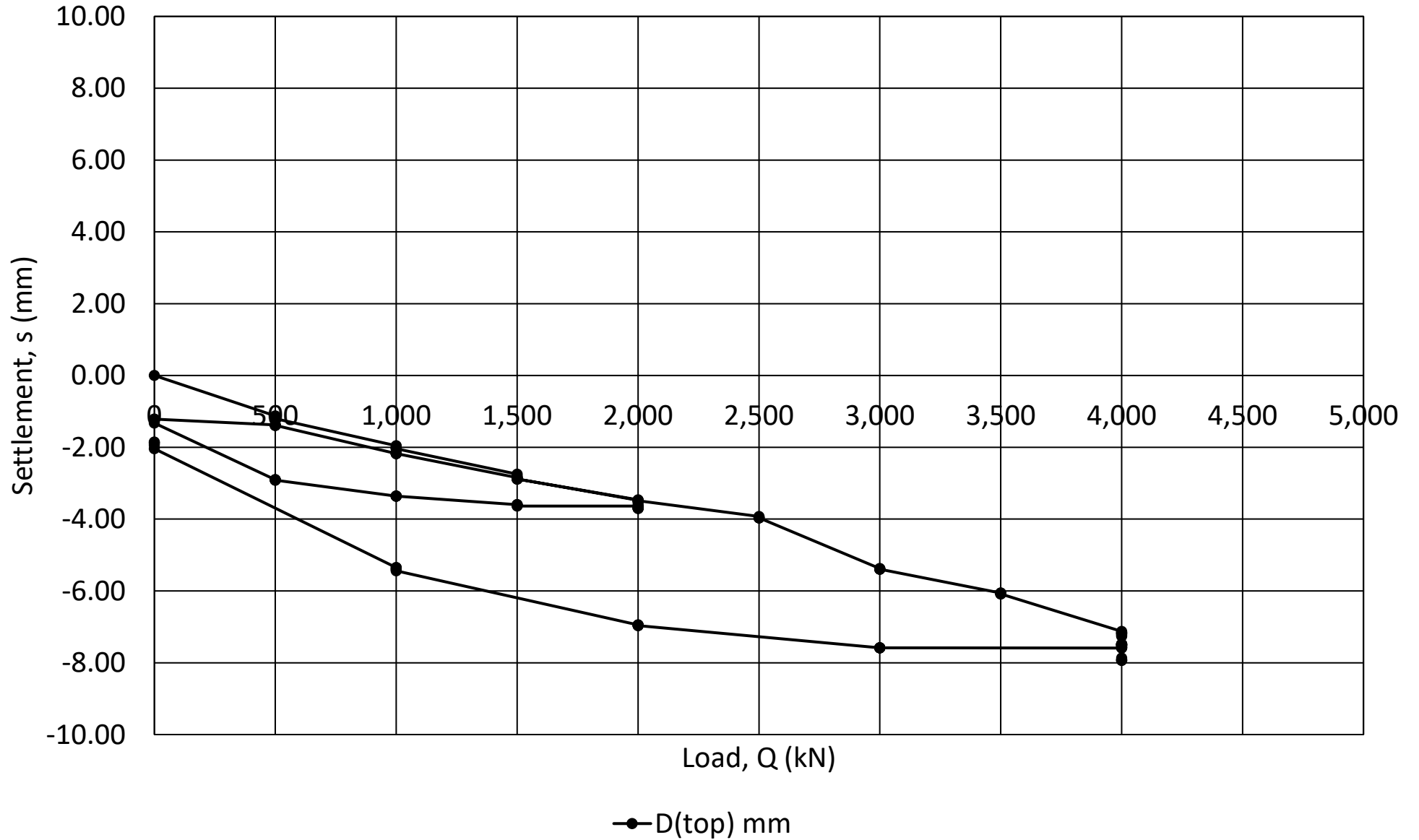

ATTACHMENT A

**Standard Operating Procedure (SOP) for Technical and Project Department
Constructing YJACK Q-s Plot from BD Pile Testing**

Note/01

The $W(up)$ is a constant value. In relatively small working load and long pile condition, the early few loading steps may have low loading, but after considerations to subtract the measured Q value with $W(up)$, the Q - D data points may have negative values to indicate "negative friction", in which this does not make sense. Hence in YJACK Plot Method, ignored $W(up)$ in plotting the Q - D Plot and considered this $W(up)$ in-conjunction with tension-compression factor to evaluate Q_u value.

Note/02

Follow Malaysian Local Practise. Refer to OCELL Test Report appendix.

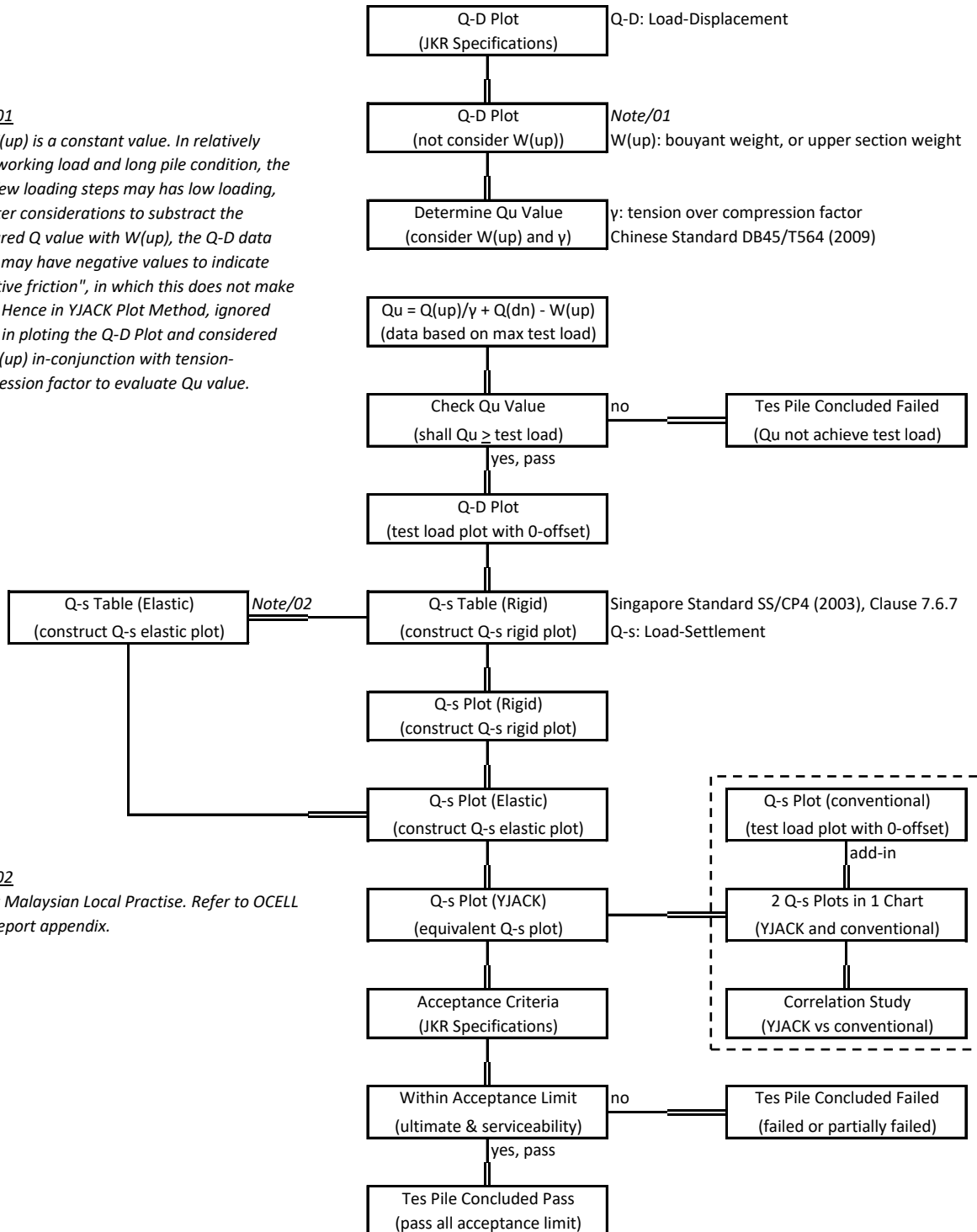

This SOP shall be deemed as YJACK Plot Method in constructing Q-s Plot from BD Testing (i.e. YPLOT Method).

Authorized By: Chief Executive Officer	Managed By: Chief Technical Officer	Effective Date: 2017/03/08
--	-------------------------------------	----------------------------

CONSTRUCTION OF THE EQUIVALENT TOP-LOADED LOAD-SETTLEMENT CURVE FROM THE RESULTS OF BI-DIRECTIONAL LOAD TEST (BDLT)

Introduction:

BDLT can provide a good estimate of a curve showing the load versus settlement of a top-loaded driven or bored pile (drilled shaft) with the following assumptions, which is consider good sense and usually conservative:

1. The end bearing load-movement curve in a top-loaded shaft has the same loads for a given movement as the net (subtract buoyant weight of pile above hydraulic jack) end bearing load-movement curve developed by the bottom of the hydraulic jack when placed at or near the bottom of the shaft.
2. The side shear load-movement curve in a top-loaded shaft has the same net shear, multiplied by an adjustment factor 'F' for a given downward movement as occurred in the BDLT for that same movement at the top of the jack in the upward direction. The same applies to the upward movement in a top-loaded tension test. Unless noted otherwise, a factor $F=0.95$ for compression in cohesionless soils and $F=0.80$ for tension tests in all soils is used.
3. The pile behaves as a rigid body, but includes the elastic compressions that are part of the movement data obtained from a bidirectional load test (BDLT). Procedure 1 interprets an equivalent top-load test (TLT) movement curve and procedure 2 corrects the effects of the additional elastic compressions in a TLT.
4. The part of the shaft below the hydraulic jack (one or multi level) has the same load-movement behavior as when top-loading the entire shaft. The subsequent 'end bearing movement curve' refers to the movement of the entire length of shaft below the jack.

Procedure 1:

Figure A shows BDLT results and Figure B shows the construction of equivalent top loaded settlement curve. Each of the curves shown has points numbered from 1 to 12 such that the same point number on each curve has the same movement magnitude.

With the above assumptions, the equivalent curve can be constructed as follows:

Select an arbitrary movement such as the 0.40 inches to give point 4 on the shaft side shear load movement curve in Figure A and record the load of 2,090 tons in shear at that movement. With the initial assumption of a rigid pile, the top of pile moves downward the same as the bottom. Therefore, find point 4 with 0.40 inches of upward movement on the end bearing load movement curve and record the corresponding load of 1,060 tons.

Adding these two loads will give the total load of 3,150 tons due to side shear plus end bearing at the same movement and thus gives point 4 on the Figure B load settlement curve for an equivalent top-loaded test. Procedure 1 can be used to obtain all the points in Figure B up to the component that moved the least at the end of the test, in this case point 5 in side shear.

Suitable hyperbolic curve fitting technique can be used for extrapolation of the side shear curve to produce end bearing movement data up to 12. Some judgment is required for deciding on the maximum number of data points to provide good fit with high correlation coefficient, r^2 . Using the same movement matching procedure described earlier, the equivalent curve to points 6 to 12 can be extended. The dashed line shown in Figure B, signify that this part of the equivalent curve depends partly on extrapolated data.

If the data warrants, the extrapolations of both side shear and end bearing to extend the equivalent curve to a greater movement than the maximum measured (point 12) will be used. An appendix in this report gives the details of the extrapolation(s) used with the present BDLT and shows the fit with the actual data.

Procedure 2:

The elastic compression in the equivalent top load test always exceeds that in the BDLT. It produces more top movement and also additional side shear movement, which then generate more side shear, more compression, etc. An exact solution of this load transfer problem requires knowing the side shear vs. vertical movement (t-y) curves for a large number of pile length increments and solving the resulting set of simultaneous equations or using finite element or finite difference simulations to obtain an approximate solution for these equations.

The attached analysis P.6 gives the equations for the elastic compressions that occur in the BDLT with one or two levels of hydraulic jacks. Analysis P.7 gives the equations for the elastic compressions that occur in the equivalent TLT. Both sets of equations do not include the elastic compression below the hydraulic jack because the same compression takes place in both the BDLT and the TLT. This is equivalent to taking $I_3 = 0$. Subtracting the BDLT from the TLT compression gives the desired additional elastic compression at the top of the TLT. The additional elastic compression is then added to the 'rigid' equivalent curve obtained from Part 1 to obtain the final, corrected equivalent load-settlement curve for the TLT on the same pile as the actual BDLT.

Note that the above p.6 and p.7 give equations for each of three assumed patterns of developed side shear stress along the pile. The pattern shown in the center of the three is applicable to any approximate determined side shear distribution. Experience has shown the initial solution for the additional elastic compression, as described above, gives an adequate and slightly conservative (high) estimate of the additional compression versus more sophisticated load-transfer analyses as described in the first paragraph of this Part II.

The analysis p.8 provides an example of calculated results in English units on a hypothetical 1-stage, single level BDLT using the simplified method in Part II with the centroid of the side shear distribution 44.1% above the base of the hydraulic jack. Figure C compares the corrected with the rigid curve of Figure B. Page 9 contains an example equivalent to that above in SI units.

The final analysis p.10 provides an example of calculated results in English units on a hypothetical 3-stage, multi level BDSLT using the simplified method in Part II with the centroid of the combined upper and middle side shear distribution 44.1% above the base of the bottom hydraulic jack. The individual centroids of the upper and middle side shear distribution lie 39.6% and 57.9% above and below the middle hydraulic jack, respectively. Figure E compares the corrected with the rigid curve. Page 11 contains an example equivalent to that above in SI units.

Other Tests: The example illustrated in [Figure A](#) has the maximum component movement in end bearing. The procedures remain the same if the maximum test movement occurred in side shear. Then we would have extrapolated end bearing to produce the dashed-line part of the reconstructed top-load settlement curve.

The example illustrated also assumes a pile top-loaded in compression. For a pile top-loaded in tension we would, based on Assumptions 2 and 3, use the upward side shear load curve in [Figure A](#), multiplied by the $F = 0.80$ noted in Assumption 2, for the equivalent top-loaded displacement curve.

Expected Accuracy: There are only five series of tests that provide the data needed to make a direct comparison between actual, full scale, top-loaded pile movement behaviour and the equivalent behaviour obtained from a BDLT by the method described herein. These involved three sites in Japan and one in Singapore, in a variety of soils, with three compression tests on bored piles (drilled shafts), one compression test on a driven pile and one tension test on a bored pile. The largest bored pile had a 1.2 m diameter and a 37 m length. The driven pile had a 1-m increment modular construction and a 9 m length. The largest top loading = 28 MN (3,150 tons).

The following references detail the aforementioned Japanese tests and the results therefore:

Kishida H. *et al.*, 1992, "Pile Loading Tests at Osaka Amenity Park Project", Paper by Mitsubishi Co., also briefly described in Schmertmann (1993, see bibliography). Compares one drilled shaft in tension and another in compression.

Ogura, H. *et al.*, 1995, "Application of Pile Toe Load Test to Cast-in-place Concrete Pile and Precast Pile", special volume 'Tsuchi-to-Kiso' on Pile Loading Test, Japanese Geotechnical Society, Vol. 3, No. 5, Ser. No. 448. Original in Japanese. Translated by M.B. Karkee, GEOTOP Corporation. Compares one drilled shaft and one driven pile, both in compression.

We compared the predicted equivalent and measured top load at three top movements in each of the above four Japanese comparisons. The top movements ranged from ¼ inch (6 mm) to 40 mm, depending on the data available.

The (equiv./meas.) ratios of the top load averaged 1.03 in the 15 comparisons with a coefficient of variation of less than 10%. These available comparisons help support the practical validity of the equivalent top load method described herein.

L.S. Peng, A.M. Koon, R. Page and C. W. Lee report the results of a class-A prediction by others of the TLT curve from a BDLT on a 1.2 m diameter, 37.2 m long bored pile in Singapore, compared to an adjacent pile with the same dimensions actually top-loaded by kentledge. They report about a 4% difference in ultimate capacity and less than 8% difference in settlements over the 1.0 to 1.5 times working load range – comparable to the accuracy noted above. Their paper was published in March 1999 in the Proceedings of the International Conference on Rail Transit, held in Singapore and published by the Association of Consulting Engineers Singapore.

B.H. Fellenius has made several finite element method (FEM) studies of a BDLT in which he adjusted the parameters to produce good load-deflection matches with the BDLT up and down load-deflection curve. He then used the same parameters to predict the TLT deflection curve. We compared the FEM-predicted curve with the equivalent load-deflection predicted by the previously described Part I and II procedures, with the results again comparable to the accuracy noted above. A paper by Fellenius *et. al.* titled "BDLT and FE Analysis of a 28 m Deep Barrette in Manila, Philippines", awaiting publication in the ASCE Journal of Geotechnical and Environmental Engineering, details one of the comparisons.

Limitations: The engineer using these results should judge the conservatism of the aforementioned assumptions and extrapolation(s) before utilizing the results for design purposes. For example, brittle failure behaviour may produce movement curves with abrupt changes in curvature (not hyperbolic). However, the hyperbolic fit method and the assumptions used usually produce reasonable equivalent top load settlement curves.

Example of the Construction of an Equivalent Top-Loaded Settlement Curve (Figure B)
From BDLT Results (Figure A)

Figure A

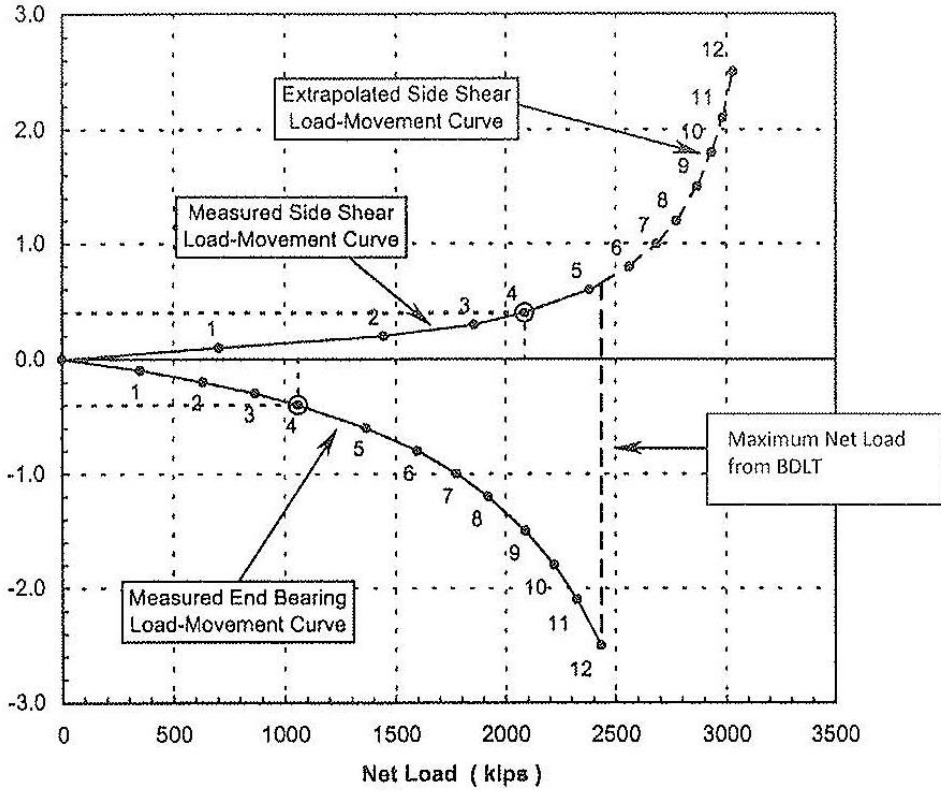
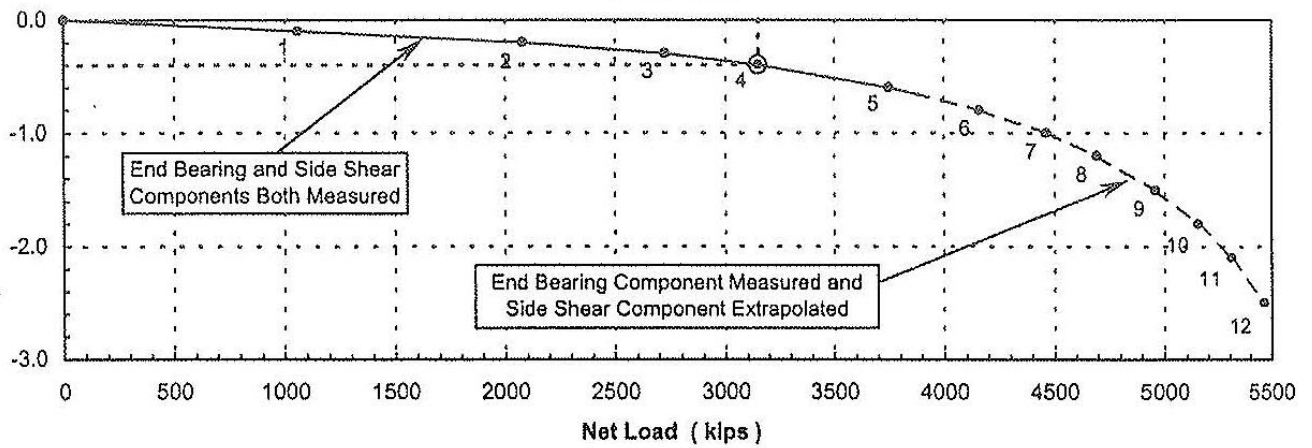
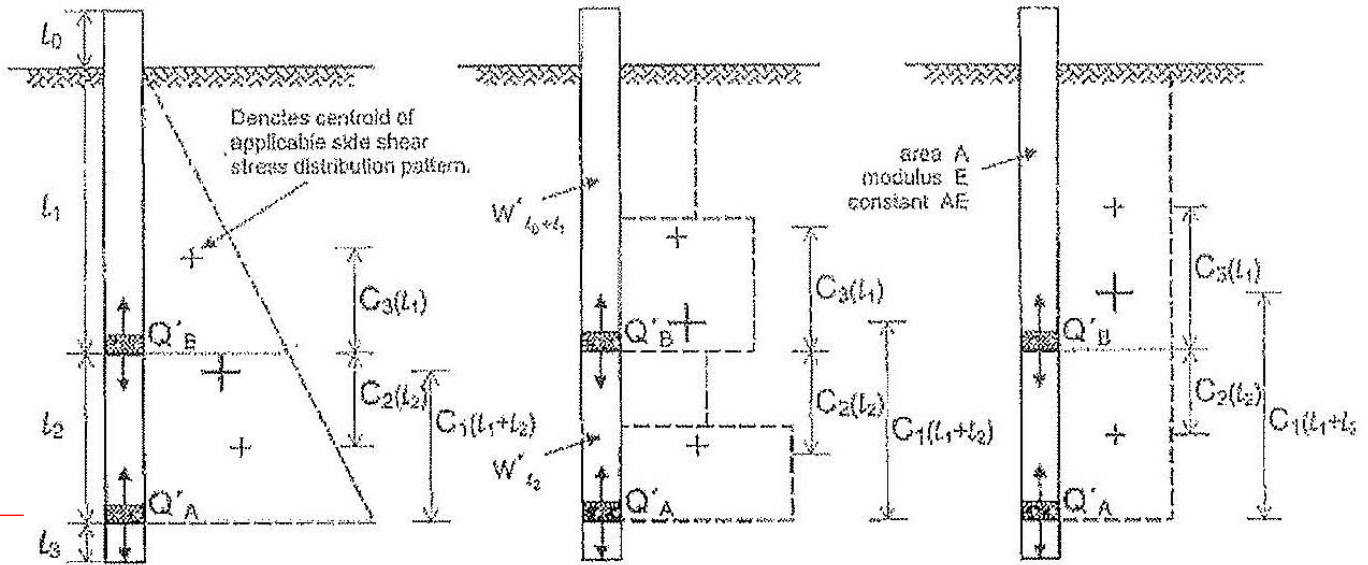

Figure B



Theoretical Elastic Compression in BDLT
Based on Pattern of Development Side Shear Stress



1-Stage Single Level Test (Q'_A only):

$$\delta_{BDLT} = \delta_{\uparrow l1} + \delta_{\downarrow l2}$$

$C_1 = \frac{1}{3}$	Centroid Factor = C_1	$C_1 = \frac{1}{2}$
$\delta_{\uparrow(l_1+l_2)} = \frac{1}{3} \frac{Q'_{TA}(l_1+l_2)}{AE}$	$\delta_{\uparrow(l_1+l_2)} = C_1 \frac{Q'_{TA}(l_1+l_2)}{AE}$	$\delta_{\uparrow(l_1+l_2)} = \frac{1}{2} \frac{Q'_{TA}(l_1+l_2)}{AE}$

3-Stage Multi Level Test (Q'_A and Q'_B):

$$\delta_{BDLT} = \delta_{\uparrow l1} + \delta_{\downarrow l2}$$

$C_3 = \frac{1}{3}$	Centroid Factor = C_3	$C_3 = \frac{1}{2}$
$\delta_{\uparrow l1} = \frac{1}{3} \frac{Q'_{TB} l_1}{AE}$	$\delta_{\uparrow l1} = C_3 \frac{Q'_{TB} l_1}{AE}$	$\delta_{\uparrow l1} = \frac{1}{3} \frac{Q'_{TB} l_1}{AE}$
$C_2 = \frac{1}{3} \left(\frac{3l_1 + 2l_2}{2l_1 + l_2} \right)$	Centroid Factor = C_2	$C_2 = \frac{1}{2}$
$\delta_{\downarrow l2} = \frac{1}{3} \left(\frac{3l_1 + 2l_2}{2l_1 + l_2} \right) \frac{Q'_{LB} l_2}{AE}$	$\delta_{\downarrow l2} = C_2 \frac{Q'_{LB} l_2}{AE}$	$\delta_{\downarrow l2} = \frac{1}{2} \frac{Q'_{LB} l_2}{AE}$

Net Loads:

$$Q'_{TA} = Q_{TA} - W'_{l_1+l_2+l_3}$$

$$Q'_{TB} = Q_{TB} - W'_{l_1+l_2}$$

$$Q'_{LB} = Q_{LB} + W'_{l_2}$$

W' = pile weight, buoyant where below water table

Q'_B is the 2nd level BD-JACK.
In YJACK Validation Program, only single level (1) YJACK installed, hence ignored Q'_B level.
Only consider Q'_A level.

Theoretical Elastic Compression in Top Loaded Test
Based on Pattern of Development Side Shear Stress

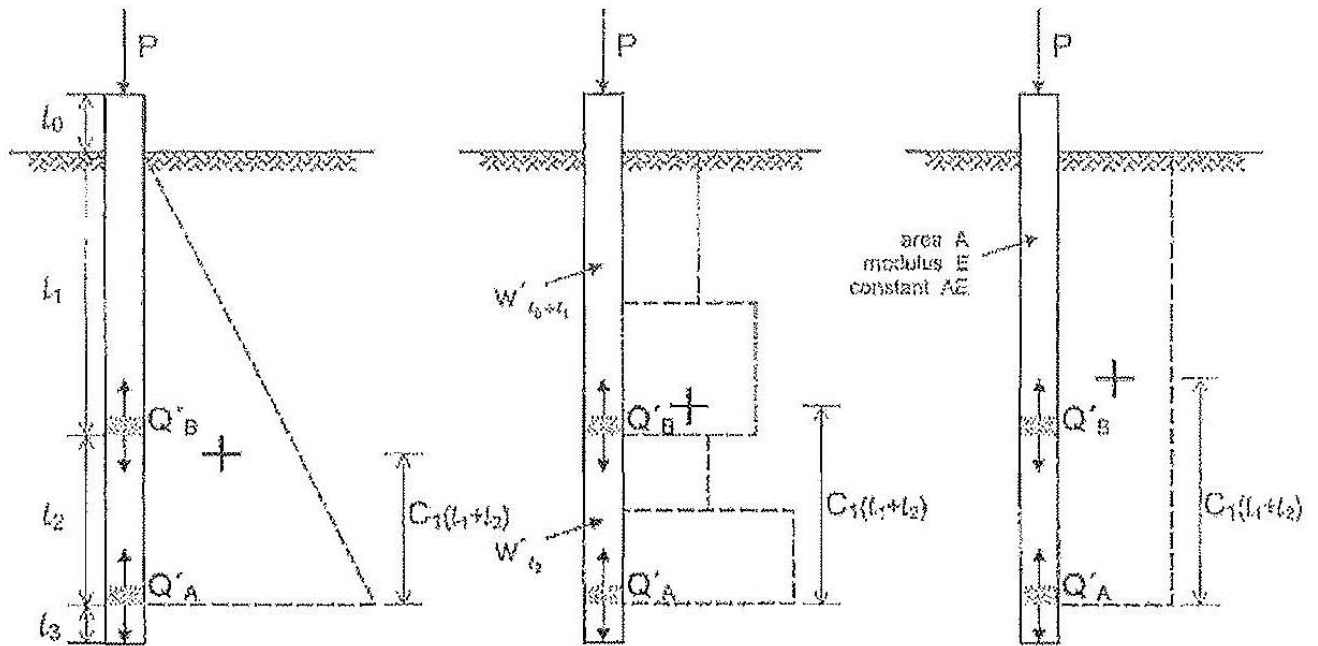

Top Loaded Test: $\delta_{TLT} = \delta_{l_0} + \delta_{l_1+l_2}$

$\delta_{l_0} = \frac{Pl_0}{AE}$	$\delta_{l_0} = \frac{Pl_0}{AE}$	$\delta_{l_0} = \frac{Pl_0}{AE}$
$C_1 = \frac{1}{3}$	Centroid Factor = C_1	$C_1 = \frac{1}{2}$
$\delta_{l_1+l_2} = \frac{(Q'_{1A} + 2P)(l_1 + l_2)}{3AE}$	$\delta_{l_1+l_2} = \frac{[(C_1)Q'_{1A} + (1-C_1)P](l_1 + l_2)}{AE}$	$\delta_{l_1+l_2} = \frac{(Q'_{1A} + P)(l_1 + l_2)}{2AE}$

Net and Equivalent Loads:

$$Q'_{1A} = Q_{1A} - W'_{l_0+l_1+l_2}$$

$$P_{\text{single}} = Q'_{1A} + Q'_{1B}$$

$$P_{\text{multi}} = Q'_{1A} + Q'_{1B} + Q'_{1C}$$

Component loads Q selected at the same (\pm) Δ_{BDSLIT} .

ATTACHMENT B

CONTROLLED COPY

Please refer to separate document.

ATTACHMENT C



CERTIFICATE OF CALIBRATION

DATE OF ISSUE : 12 May 2016

CERTIFICATE NO : SST/SA/R/2016E/784

ISSUED BY : SIRIM Standards Technology Sdn. Bhd.

(Co No.:292201-P)

Lot 12, 18 & 20,

Jalan Beremban 15/12,Seksyen 15,

40200 Shah Alam,

Selangor Darul Ehsan

Tel:+603-55109066 Fax:+603-55109077

PAGE 1 OF 2 PAGES

APPROVED SIGNATORIES

Mohd Hashim Bin Effandi

Submitted by : YJack Technology Sdn Bhd
No 25-2, Jalan Pandan Prima
Dataran Pandan Prima
55100 Kuala Lumpur Malaysia
Attn:Mr. Jimmy Wai

Job No. : SA2016-3049-1

Date Received : 12/05/2016

Instrument : Displacement Transducer

Manufacturer : RSI

Model No. : PM-52L

Serial No. : 20141

Instrument Condition When Received :

Physically in good condition

Instrument Condition When Returned :

1. Calibrated and test serviceable
2. Calibration due date requested by customer
3. The user should be aware that there are a number of factors that may caused this instrument to drift out of calibration before the specified calibration interval has expired.

Environmental Condition:-

Average Temperature : (20 ± 1) °C

Average Relative Humidity : (58 ± 1) %RH

Calibration Date : 12 May 2016

Requested Cal.Due Date : 12 May 2017

Calibration Method :

This instrument was calibrated using the calibration procedures No. MSD/0010 Rev 5.0

Calibration Standard(s) Used :

Instrument Type :	Serial No. :	Cal. Due Date :	Cal. Cert. No.:	Traceability :
Gauge Block	183102	18/02/2017	SST/SA/IR/2016B/25	SST(SA)/NML(M'SIA)

The standard instruments used in this calibration are traceable to either the National Standards maintained at the National Metrology Laboratory, SIRIM Berhad or other recognised International Standard Laboratories

Calibration Sticker No.: SA-05-784

Measurement Uncertainty : ± 0.05 mm

The uncertainty calculation is based on the ISO guide to the expression of uncertainty in measurement.

Coverage Factor k : 2

Approved Signatory

Mohd Hashim Bin Effandi

The uncertainties are for a confidence probability of approximately 95%

This certificate is issued in accordance with the conditions of accreditation granted by the SAMM which has assessed the measurement capability of the laboratory and its traceability to recognised national standards and to the units of measurement realised at the corresponding national standards laboratory. Copyright of this certificate is owned by the issuing laboratory and may not be reproduced other than in full except with the prior written approval of the Head of the issuing laboratory.



CERTIFICATE OF CALIBRATION

DATE OF ISSUE: 12 May 2016

CERTIFICATE NUMBER: SST/SA/R/2016E/784

PAGE 2 OF 2 PAGES

Instrument : Displacement Transducer

Serial No. : 20141

CALIBRATION RESULTS

Nominal Value (mm)	Calibrated Value (mm)	Tolerance (mm)
0.0	0.00	N/A
10.0	9.90	N/A
20.0	19.92	N/A
30.0	30.91	N/A
40.0	40.90	N/A
50.0	49.90	N/A

Note: Tolerance not provided by user

Calibrated by:

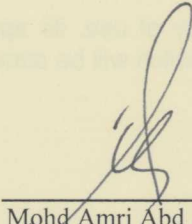
Mohd Amri Abd Aziz

The uncertainties are for a confidence probability of approximately 95%

This certificate is issued in accordance with the conditions of accreditation granted by the SAMM which has assessed the measurement capability of the laboratory and its traceability to recognised national standards and to the units of measurement realised at the corresponding national standards laboratory. Copyright of this certificate is owned by the issuing laboratory and may not be reproduced other than in full except with the prior written approval of the Head of the issuing laboratory.



CERTIFICATE OF CALIBRATION

DATE OF ISSUE : 12 May 2016

CERTIFICATE NO : SST/SA/R/2016E/785

ISSUED BY : SIRIM Standards Technology Sdn. Bhd.
(Co No.:292201-P)
Lot 12, 18 & 20,
Jalan Beremban 15/12,Seksyen 15,
40200 Shah Alam,
Selangor Darul Ehsan
Tel:+603-55109066 Fax:+603-55109077

PAGE 1 OF 2 PAGES

APPROVED SIGNATORIES

Mohd Hashim Bin Effandi

Submitted by : YJack Technology Sdn Bhd
No 25-2, Jalan Pandan Prima
Dataran Pandan Prima
55100 Kuala Lumpur Malaysia
Attn:Mr. Jimmy Wai

Job No. : SA2016-3049-2
Date Received : 12/05/2016

Instrument : Displacement Transducer
Manufacturer : RSI

Model No. : PM-52L
Serial No. : 20142

Instrument Condition When Received :
Physically in good condition

Instrument Condition When Returned :

- 1.Calibrated and test serviceable
- 2.Calibration due date requested by customer
- 3.The user should be aware that there are a number of factors that may caused this instrument to drift out of calibration before the specified calibration interval has expired.

Environmental Condition:-

Average Temperature : (20 ± 1) °C

Average Relative Humidity : (58 ± 1) %RH

Calibration Date : 12 May 2016

Requested Cal.Due Date : 12 May 2017

Calibration Method :

This instrument was calibrated using the calibration procedures No. MSD/0010 Rev 5.0

Calibration Standard(s) Used :

Instrument Type :	Serial No. :	Cal. Due Date :	Cal. Cert. No.:	Traceability :
Gauge Block	183102	18/02/2017	SST/SA/IR/2016B/25	SST(SA)/NML(M'SIA)

The standard instruments used in this calibration are traceable to either the National Standards maintained at the National Metrology Laboratory, SIRIM Berhad or other recognised International Standard Laboratories

Calibration Sticker No.: SA-05-785

Measurement Uncertainty : ± 0.05 mm

The uncertainty calculation is based on the ISO guide to the expression of uncertainty in measurement.

Coverage Factor k : 2

Approved Signatory
Mohd Hashim Bin Effandi

The uncertainties are for a confidence probability of approximately 95%

This certificate is issued in accordance with the conditions of accreditation granted by the SAMM which has assessed the measurement capability of the laboratory and its traceability to recognised national standards and to the units of measurement realised at the corresponding national standards laboratory. Copyright of this certificate is owned by the issuing laboratory and may not be reproduced other than in full except with the prior written approval of the Head of the issuing laboratory.

CERTIFICATE OF CALIBRATION

DATE OF ISSUE: 12 May 2016

CERTIFICATE NUMBER: SST/SA/R/2016E/785

PAGE 2 OF 2 PAGES

Instrument : Displacement Transducer

Serial No. : 20142

CALIBRATION RESULTS

Nominal Value (mm)	Calibrated Value (mm)	Tolerance (mm)
0.0	0.00	N/A
10.0	9.95	N/A
20.0	19.89	N/A
30.0	30.04	N/A
40.0	39.98	N/A
50.0	50.02	N/A

Note: Tolerance not provided by user

Calibrated by:

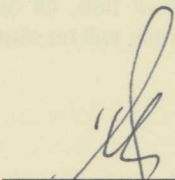
Mohd Amri Abd Aziz

The uncertainties are for a confidence probability of approximately 95%

This certificate is issued in accordance with the conditions of accreditation granted by the SAMM which has assessed the measurement capability of the laboratory and its traceability to recognised national standards and to the units of measurement realised at the corresponding national standards laboratory. Copyright of this certificate is owned by the issuing laboratory and may not be reproduced other than in full except with the prior written approval of the Head of the issuing laboratory.



CERTIFICATE OF CALIBRATION

DATE OF ISSUE : 12 May 2016

CERTIFICATE NO : SST/SA/R/2016E/786

ISSUED BY : SIRIM Standards Technology Sdn. Bhd.

(Co No.:292201-P)

Lot 12, 18 & 20,

Jalan Beremban 15/12,Seksyen 15,

40200 Shah Alam,

Selangor Darul Ehsan

Tel:+603-55109066 Fax:+603-55109077

PAGE 1 OF 2 PAGES

APPROVED SIGNATORIES

Mohd Hashim Bin Effandi

Submitted by : YJack Technology Sdn Bhd

No 25-2, Jalan Pandan Prima

Dataran Pandan Prima

55100 Kuala Lumpur Malaysia

Attn:Mr. Jimmy Wai

Job No. : SA2016-3049-3

Date Received : 12/05/2016

Instrument : Displacement Transducer

Manufacturer : RSI

Model No. : PM-52L

Serial No. : 20143

Instrument Condition When Received :

Physically in good condition

Instrument Condition When Returned :

1.Calibrated and test serviceable

2.Calibration due date requested by customer

3.The user should be aware that there are a number of factors that may caused this instrument to drift out of calibration before the specified calibration interval has expired.

Environmental Condition:-

Average Temperature : (20 ± 1) °C

Average Relative Humidity : (58 ± 1) %RH

Calibration Date : 12 May 2016

Requested Cal.Due Date : 12 May 2017

Calibration Method :

This instrument was calibrated using the calibration procedures No. MSD/0010 Rev 5.0

Calibration Standard(s) Used :

<u>Instrument Type :</u>	<u>Serial No. :</u>	<u>Cal. Due Date :</u>	<u>Cal. Cert. No.:</u>	<u>Traceability :</u>
Gauge Block	183102	18/02/2017	SST/SA/IR/2016B/25	SST(SA)/NML(M'SIA)

The standard instruments used in this calibration are traceable to either the National Standards maintained at the National Metrology Laboratory, SIRIM Berhad or other recognised International Standard Laboratories

Calibration Sticker No.: SA-05-786

Measurement Uncertainty : ± 0.05 mm

The uncertainty calculation is based on the ISO guide to the expression of uncertainty in measurement.

Coverage Factor k : 2

Approved Signatory

Mohd Hashim Bin Effandi

The uncertainties are for a confidence probability of approximately 95%

This certificate is issued in accordance with the conditions of accreditation granted by the SAMM which has assessed the measurement capability of the laboratory and its traceability to recognised national standards and to the units of measurement realised at the corresponding national standards laboratory. Copyright of this certificate is owned by the issuing laboratory and may not be reproduced other than in full except with the prior written approval of the Head of the issuing laboratory.

CERTIFICATE OF CALIBRATION

DATE OF ISSUE: 12 May 2016

CERTIFICATE NUMBER: SST/SA/R/2016E/786

PAGE 2 OF 2 PAGES

Instrument : Displacement Transducer

Serial No. : 20143

CALIBRATION RESULTS

Nominal Value (mm)	Calibrated Value (mm)	Tolerance (mm)
0.0	0.00	N/A
10.0	10.02	N/A
20.0	20.04	N/A
30.0	30.05	N/A
40.0	40.06	N/A
50.0	49.93	N/A

Note: Tolerance not provided by user

Calibrated by:

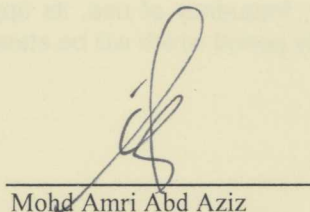

Mohd Amri Abd Aziz

The uncertainties are for a confidence probability of approximately 95%

This certificate is issued in accordance with the conditions of accreditation granted by the SAMM which has assessed the measurement capability of the laboratory and its traceability to recognised national standards and to the units of measurement realised at the corresponding national standards laboratory. Copyright of this certificate is owned by the issuing laboratory and may not be reproduced other than in full except with the prior written approval of the Head of the issuing laboratory.



CERTIFICATE OF CALIBRATION

DATE OF ISSUE : 12 May 2016

CERTIFICATE NO : SST/SA/R/2016E/787

ISSUED BY : SIRIM Standards Technology Sdn. Bhd.

(Co No.:292201-P)

Lot 12, 18 & 20,

Jalan Beremban 15/12,Seksyen 15,

40200 Shah Alam,

Selangor Darul Ehsan

Tel:+603-55109066 Fax:+603-55109077

PAGE 1 OF 2 PAGES

APPROVED SIGNATORIES

Mohd Hashim Bin Effandi

Submitted by : YJack Technology Sdn Bhd

No 25-2, Jalan Pandan Prima

Dataran Pandan Prima

55100 Kuala Lumpur Malaysia

Attn:Mr. Jimmy Wai

Job No. : SA2016-3049-4

Date Received : 12/05/2016

Instrument : Displacement Transducer

Manufacturer : RSI

Model No. : PM-52L

Serial No. : 20144

Instrument Condition When Received :

Physically in good condition

Instrument Condition When Returned :

1.Calibrated and test serviceable

2.Calibration due date requested by customer

3.The user should be aware that there are a number of factors that may caused this instrument to drift out of calibration before the specified calibration interval has expired.

Environmental Condition:-

Average Temperature : (20 ± 1) °C

Average Relative Humidity : (58 ± 1) %RH

Calibration Date : 12 May 2016

Requested Cal.Due Date : 12 May 2017

Calibration Method :

This instrument was calibrated using the calibration procedures No. MSD/0010 Rev 5.0

Calibration Standard(s) Used :

Instrument Type :	Serial No. :	Cal. Due Date :	Cal. Cert. No.:	Traceability :
Gauge Block	183102	18/02/2017	SST/SA/IR/2016B/25	SST(SA)/NML(M'SIA)

The standard instruments used in this calibration are traceable to either the National Standards maintained at the National Metrology Laboratory, SIRIM Berhad or other recognised International Standard Laboratories

Calibration Sticker No.: SA-05-787

Measurement Uncertainty : Refer to calibration results

The uncertainty calculation is based on the ISO guide to the expression of uncertainty in measurement.

Coverage Factor k : 2

Approved Signatory

Mohd Hashim Bin Effandi

The uncertainties are for a confidence probability of approximately 95%

This certificate is issued in accordance with the conditions of accreditation granted by the SAMM which has assessed the measurement capability of the laboratory and its traceability to recognised national standards and to the units of measurement realised at the corresponding national standards laboratory. Copyright of this certificate is owned by the issuing laboratory and may not be reproduced other than in full except with the prior written approval of the Head of the issuing laboratory.

CERTIFICATE OF CALIBRATION

DATE OF ISSUE: 12 May 2016

CERTIFICATE NUMBER: SST/SA/R/2016E/787

PAGE 2 OF 2 PAGES

Instrument : Displacement Transducer

Serial No. : 20144

CALIBRATION RESULTS

Nominal Value (mm)	Calibrated Value (mm)	Tolerance (mm)
0.0	0.00	N/A
10.0	9.88	N/A
20.0	19.89	N/A
30.0	30.04	N/A
40.0	40.01	N/A
50.0	49.98	N/A

Note: Tolerance not provided by user

Calibrated by:

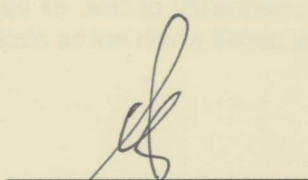
Mohd Amri Abd Aziz

The uncertainties are for a confidence probability of approximately 95%

This certificate is issued in accordance with the conditions of accreditation granted by the SAMM which has assessed the measurement capability of the laboratory and its traceability to recognised national standards and to the units of measurement realised at the corresponding national standards laboratory. Copyright of this certificate is owned by the issuing laboratory and may not be reproduced other than in full except with the prior written approval of the Head of the issuing laboratory.



CERTIFICATE OF CALIBRATION

DATE OF ISSUE : 12 May 2016

CERTIFICATE NO : SST/SA/R/2016E/788

ISSUED BY : SIRIM Standards Technology Sdn. Bhd.
(Co No.:292201-P)
Lot 12, 18 & 20,
Jalan Beremban 15/12,Seksyen 15,
40200 Shah Alam,
Selangor Darul Ehsan
Tel:+603-55109066 Fax:+603-55109077

PAGE 1 OF 2 PAGES

APPROVED SIGNATORIES

Mohd Hashim Bin Effandi

Submitted by : YJack Technology Sdn Bhd
No 25-2, Jalan Pandan Prima
Dataran Pandan Prima
55100 Kuala Lumpur Malaysia
Attn:Mr. Jimmy Wai

Job No. : SA2016-3049-5
Date Received : 12/05/2016

Instrument : Displacement Transducer
Manufacturer : RSI

Model No. : PM-52L
Serial No. : 20147

Instrument Condition When Received :
Physically in good condition

Instrument Condition When Returned :

- 1.Calibrated and test serviceable
- 2.Calibration due date requested by customer
- 3.The user should be aware that there are a number of factors that may caused this instrument to drift out of calibration before the specified calibration interval has expired.

Environmental Condition:-

Average Temperature : (20 ± 1) °C

Average Relative Humidity : (58 ±) %RH

Calibration Date : 12 May 2016

Requested Cal.Due Date : 12 May 2017

Calibration Method :

This instrument was calibrated using the calibration procedures No. MSD/0010 Rev 5.0

Calibration Standard(s) Used :

Instrument Type :	Serial No. :	Cal. Due Date :	Cal. Cert. No.:	Traceability :
Gauge Block	183102	18/02/2017	SST/SA/IR/2016B/25	SST(SA)/NML(M'SIA)

The standard instruments used in this calibration are traceable to either the National Standards maintained at the National Metrology Laboratory, SIRIM Berhad or other recognised International Standard Laboratories

Calibration Sticker No.: SA-05-788

Measurement Uncertainty : ± 0.05 mm

The uncertainty calculation is based on the ISO guide to the expression of uncertainty in measurement.

Coverage Factor k : 2

Approved Signatory
Mohd Hashim Bin Effandi

The uncertainties are for a confidence probability of approximately 95%

This certificate is issued in accordance with the conditions of accreditation granted by the SAMM which has assessed the measurement capability of the laboratory and its traceability to recognised national standards and to the units of measurement realised at the corresponding national standards laboratory. Copyright of this certificate is owned by the issuing laboratory and may not be reproduced other than in full except with the prior written approval of the Head of the issuing laboratory.

CERTIFICATE OF CALIBRATION

DATE OF ISSUE: 12 May 2016

CERTIFICATE NUMBER: SST/SA/R/2016E/788

PAGE 2 OF 2 PAGES

Instrument : Displacement Transducer

Serial No. : 20147

CALIBRATION RESULTS

Nominal Value (mm)	Calibrated Value (mm)	Tolerance (mm)
0.0	0.00	N/A
10.0	10.06	N/A
20.0	20.07	N/A
30.0	30.09	N/A
40.0	40.04	N/A
50.0	50.02	N/A

Note: Tolerance not provided by user

Calibrated by:

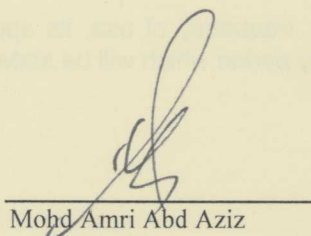
Mohd Amri Abd Aziz

The uncertainties are for a confidence probability of approximately 95%

This certificate is issued in accordance with the conditions of accreditation granted by the SAMM which has assessed the measurement capability of the laboratory and its traceability to recognised national standards and to the units of measurement realised at the corresponding national standards laboratory. Copyright of this certificate is owned by the issuing laboratory and may not be reproduced other than in full except with the prior written approval of the Head of the issuing laboratory.



CERTIFICATE OF CALIBRATION

DATE OF ISSUE : 12 May 2016

CERTIFICATE NO : SST/SA/R/2016E/789

ISSUED BY : SIRIM Standards Technology Sdn. Bhd.

(Co No.:292201-P)

Lot 12, 18 & 20,

Jalan Beremban 15/12,Seksyen 15,

40200 Shah Alam,

Selangor Darul Ehsan

Tel:+603-55109066 Fax:+603-55109077

PAGE 1 OF 2 PAGES

APPROVED SIGNATORIES

Mohd Hashim Bin Effandi

Submitted by : YJack Technology Sdn Bhd
No 25-2, Jalan Pandan Primal
Dataran Pandan Prima
55100 Kuala Lumpur Malaysia
Attn:Mr. Jimmy Wai

Job No. : SA2016-3049-6

Date Received : 12/05/2016

Instrument : Displacement Transducer

Manufacturer : RSI

Model No. : PM-52L

Serial No. : 20148

Instrument Condition When Received :

Physically in good condition

Instrument Condition When Returned :

- 1.Calibrated and test serviceable
- 2.Calibration due date requested by customer
- 3.The user should be aware that there are a number of factors that may caused this instrument to drift out of calibration before the specified calibration interval has expired.

Environmental Condition:-

Average Temperature : (20 ± 1) °C

Average Relative Humidity : (58 ± 1) %RH

Calibration Date : 12 May 2016

Requested Cal.Due Date : 12 May 2017

Calibration Method :

This instrument was calibrated using the calibration procedures No. MSD/0010 Rev 5.0

Calibration Standard(s) Used :

<u>Instrument Type :</u>	<u>Serial No. :</u>	<u>Cal. Due Date :</u>	<u>Cal. Cert. No.:</u>	<u>Traceability :</u>
Gauge Block	183102	18/02/2017	SST/SA/IR/2016B/25	SST(SA)/NML(M'SIA)

The standard instruments used in this calibration are traceable to either the National Standards maintained at the National Metrology Laboratory, SIRIM Berhad or other recognised International Standard Laboratories

Calibration Sticker No.: SA-05-789

Measurement Uncertainty : ± 0.05 mm

The uncertainty calculation is based on the ISO guide to the expression of uncertainty in measurement.

Coverage Factor k : 2

Approved Signatory

Mohd Hashim Bin Effandi

The uncertainties are for a confidence probability of approximately 95%

This certificate is issued in accordance with the conditions of accreditation granted by the SAMM which has assessed the measurement capability of the laboratory and its traceability to recognised national standards and to the units of measurement realised at the corresponding national standards laboratory. Copyright of this certificate is owned by the issuing laboratory and may not be reproduced other than in full except with the prior written approval of the Head of the issuing laboratory.



CERTIFICATE OF CALIBRATION

DATE OF ISSUE: 12 May 2016

CERTIFICATE NUMBER: SST/SA/R/2016E/789

PAGE 2 OF 2 PAGES

Instrument : Displacement Transducer

Serial No. : 20148

CALIBRATION RESULTS

Nominal Value (mm)	Calibrated Value (mm)	Tolerance (mm)
0.0	0.00	N/A
10.0	10.02	N/A
20.0	20.04	N/A
30.0	30.07	N/A
40.0	40.02	N/A
50.0	49.98	N/A

Note: Tolerance not provided by user

Calibrated by:

Mohd Amri Abd Aziz

The uncertainties are for a confidence probability of approximately 95%

This certificate is issued in accordance with the conditions of accreditation granted by the SAMM which has assessed the measurement capability of the laboratory and its traceability to recognised national standards and to the units of measurement realised at the corresponding national standards laboratory. Copyright of this certificate is owned by the issuing laboratory and may not be reproduced other than in full except with the prior written approval of the Head of the issuing laboratory.



CERTIFICATE OF CALIBRATION

DATE OF ISSUE : 12 May 2016

CERTIFICATE NO : SST/SA/R/2016E/805

ISSUED BY : SIRIM Standards Technology Sdn. Bhd.
(Co No.:292201-P)
Lot 12, 18 & 20,
Jalan Beremban 15/12,Seksyen 15,
40200 Shah Alam,
Selangor Darul Ehsan
Tel:+603-55109066 Fax:+603-55109077

PAGE 1 OF 2 PAGES

APPROVED SIGNATORIES

Abdul Latip Bin Alias

Submitted by : YJack Technology Sdn Bhd
No 25-2, Jalan Pandan Primal
Dataran Pandan Prima
55100 Kuala Lumpur Malaysia
Attn:Mr. Jimmy Wai

Job No. : SA2016-3049-8
Date Received : 12/05/2016

Instrument : Pressure Transducer (Force)
Manufacturer : Shanghai Shendi Sensor & Technology

Model No. : PT124B-210-M20
Serial No. : 150131097

Instrument Condition When Received :
Physically in good condition

Instrument Condition When Returned :
1. Calibrated and test serviceable
2. Calibration due date requested by customer
3. The user should be aware that there are a number of factors that may caused this instrument to drift out of calibration before the specified calibration interval has expired.

Environmental Condition:-

Average Temperature : (23 ± 1) °C

Average Relative Humidity : (54 ± 1) %RH

Calibration Date : 12 May 2016

Requested Cal.Due Date : 12 May 2017

Calibration Method :

This instrument was calibrated using the calibration procedures No.MSP/0011 Rev.8.0

Calibration Standard(s) Used :

Instrument Type :	Serial No. :	Cal. Due Date :	Cal. Cert. No.:	Traceability :
Digital Test Gauge	963071	12/02/2017	SST/SA/TR/2016B/22	SST(SA)/NML(M'SIA)
Budenberg Comparator	580/29944	-	-	-

The standard instruments used in this calibration are traceable to either the National Standards maintained at the National Metrology Laboratory, SIRIM Berhad or other recognised International Standard Laboratories

Calibration Sticker No.: SA-05-805

Measurement Uncertainty : ± 2 kN

The uncertainty calculation is based on the ISO guide to the expression of uncertainty in measurement.

Coverage Factor k : 2

Approved Signatory
Abdul Latip Bin Alias

The uncertainties are for a confidence probability of approximately 95%

This certificate is issued in accordance with the conditions of accreditation granted by the SAMM which has assessed the measurement capability of the laboratory and its traceability to recognised national standards and to the units of measurement realised at the corresponding national standards laboratory. Copyright of this certificate is owned by the issuing laboratory and may not be reproduced other than in full except with the prior written approval of the Head of the issuing laboratory.

CERTIFICATE OF CALIBRATION

DATE OF ISSUE: 12 May 2016

CERTIFICATE NUMBER: SST/SA/R/2016E/805

PAGE 2 OF 2 PAGES

Instrument : Pressure Transducer (Force) Serial No. : 150131097

CALIBRATION RESULTS

Range : 2000 kN Graduation : 1 kN

Standard Applied (kN)	Actual Equipment Reading (kN)				Limits
	Increase		Decrease		
	Before Adjustment	After Adjustment	Before Adjustment	After Adjustment	
0	0	N/A	0	N/A	N/A
200	198	N/A	198	N/A	N/A
400	398	N/A	398	N/A	N/A
600	597	N/A	597	N/A	N/A
800	794	N/A	794	N/A	N/A
1000	993	N/A	993	N/A	N/A
1200	1192	N/A	1192	N/A	N/A
1600	1590	N/A	1590	N/A	N/A
2000	1985	N/A	-	-	N/A

Note : No adjustment done.
: Limits not available (N/A)
: Inner diameter = 300 mm

Calibrated By :



Muhamad Ghulwani Ab Ghalib

The uncertainties are for a confidence probability of approximately 95%

This certificate is issued in accordance with the conditions of accreditation granted by the SAMM which has assessed the measurement capability of the laboratory and its traceability to recognised national standards and to the units of measurement realised at the corresponding national standards laboratory. Copyright of this certificate is owned by the issuing laboratory and may not be reproduced other than in full except with the prior written approval of the Head of the issuing laboratory.



CORRELATION REPORT

BI-DIRECTIONAL PILE LOAD TESTING OF PILES

Validation Test of YJACK Bi-Directional Pile Load Test as the Alternative Pile Load Test Method Compared to Conventional Kentledge Method on Driven & Injection Concrete Piles.

**Project Case Study: Muar, 6*YJACK Pile Tests (Stage 1: 4*MLT + Stage 2: 2*QLT)
Pile Driving System: Injection Piles on 4*Spun Concrete Pile 300mm, SC300Ø
CCGF Research Grant Milestone: Product Proof of Concept**

PREPARED FOR:

RESEARCH GRANT:

**Concept to Commercialization Gap Fund (CCGF)
High Impact Program 2 (HIP2)**

GRANT MANAGER:

**Agensi Inovasi Malaysia (AIM)
SME Corporation Malaysia (SME Corp)
PlaTCOM Ventures Sdn Bhd (PlaTCOM)**

RESEARCH COLLABORATOR:

**Universiti Tun Hussein Onn Malaysia (UTHM)
UTHM Commercial Sdn Bhd (UTHMC)**

VALIDATION INSTITUTION:

**Construction Research Institute Malaysia (CREAM)
Technical Opinion Program (TOP)**

Prepared by:

Report Serial	Report No	Revision No	Issued Date
BDPLT-YJMY111	1	1	2017/APR/01



TABLE OF CONTENTS

	Page
COVER PAGE	1
TABLE OF CONTENTS	2
EXECUTIVE SUMMARY	3
VALIDATION BACKGROUND	4
VALIDATION PRODUCT – YJACK	4
VALIDATION OBJECTIVE	5
PILE DESIGN	5
YJACK MODEL	5
TERMINATION CRITERIA	6
PILE INSTALLATION	6
PILE LOCATION	6
INSTALLATION TERMINATION	7
INSTALLATION BEHAVIOR	7
YJACK TEST	8
PHASE 1: YJACK VALIDATION RESULTS	9
PHASE 1: YJACK VALIDATION CORRELATIONS	13
PHASE 2: YJACK VALIDATION RESULTS	18
PHASE 2: YJACK VALIDATION CORRELATIONS	21
CORRELATION SUMMARY	24
VALIDATION CONCLUSION	25
APPENDIX A1: Pile Installation Records	
APPENDIX A2: Bore Hole Records	
APPENDIX B: YJACK Bi-Directional Pile Load Test Loading Schedule	
APPENDIX C1: YJACK Bi-Directional Pile Load Test Results using MLT	
APPENDIX C2: YJACK Bi-Directional Pile Load Test Results using QLT	
APPENDIX D: Field Sheets	
APPENDIX E: Kentledge Pile Load Test Q-s Plots	
ATTACHMENT A: Standard Operating Procedure (SOP) in Constructing Q-s Plot from YJACK BD Pile Testing	
ATTACHMENT B: YJACK World Patent PCT/USA US 20170073922 A1	
ATTACHMENT C: Calibration Certificates	



EXECUTIVE SUMMAY

The objectives of the tests were to validate the newly invented YJACK on driven concrete piles compared to conventional kentledge pile load test system in terms of:

- (1) the functionality, and
- (2) the accuracy

This YJACK validation correlation tests were performed at Project Case Study at Muar on 2015/OCT/10-12 with 6*NOS YJACK pile tests as following:

- Validation Phase 1: maintained load tests (MLT) on Test Pile # TOP1A & 1B, TOP2A & 2B to test load 600kN
- Validation Phase 2: quick load tests (QLT) on Test Pile # TOP1A & 1B to test load 900kN

The following is the summary of the correlation results obtained from Correlation Phase 1 and Phase 2.

Correlation Method # 1

The following is the correlation using load test settlement at working and test loads as the correlation base data:

Pile ID	TOP1A	TOP1B	TOP2A	TOP2B	TOP1A	TOP1B
Loading Procedure	MLT	MLT	MLT	MLT	QLT	QLT
Average Accuracy	94.2%	94.7%	93.3%	91.2%	87.4%	83.1%
Accuracy Level *	High	High	High	High	High	High
Average Accuracy	90.7%					

* High if Accuracy ≥ 80%; Moderate if 50% > Accuracy < 80%; Low if Accuracy ≤ 50%

Correlation Method # 2

The following is the correlation using acceptable settlement at working and test loads as the correlation base data:

Pile ID	TOP1A	TOP1B	TOP2A	TOP2B	TOP1A	TOP1B
Loading Procedure	MLT	MLT	MLT	MLT	QLT	QLT
Average Accuracy	98.5%	98.6%	98.8%	98.6%	96.6%	96.9%
Accuracy Level *	High	High	High	High	High	High
Average Accuracy	98.0%					

* High if Accuracy ≥ 80%; Moderate if 50% > Accuracy < 80%; Low if Accuracy ≤ 50%

The following is the validation conclusions for functionality and accuracy of the newly invented YJACK.

- (1) Validation for the functionality: the YJACKs are fully performed well in terms of functionality in installation and testing.
- (2) Validation for the accuracy: the YJACKs are fully performed well in terms of accuracy in terms of ultimate (i.e. the load) and serviceability (i.e. settlement) design considerations.

VALIDATION BACKGROUND

PlatCOM Ventures Sdn Bhd is the national technology commercialization platform of Malaysia. It is a wholly-owned subsidiary company of Agensi Inovasi Malaysia (AIM) formed in collaboration with SME Corporation Malaysia (SME Corp) under one of its six High Impact Programmes (HIPs) in SME Master Plan 2012-2020.

PlatCOM Ventures has a mission: to turn the creative ideas of our inventors and entrepreneurs into successful products and services that change the world.

The model addresses the innovation gaps through a holistic and 'market-driven' approach in supporting innovation and industrial competitiveness. It is designed to remove market and financing barriers to innovation.

The program provides necessary support from 'concept to commercialization'. This is done through the provision of access to technical assistance, market intelligence, incubation facilities, testing facilities and other relevant services - all in a single platform.

VALIDATION PRODUCT – YJACK

The validation product is YJACK. It is a static pile load test method based on bi-directional principle. It is an alternative and economical method to conventional maintained load test using kentledge blocks or reaction piles methods.

This invention is by far the best compared to conventional method. The YJACK solves problems by:

- a. cost saving;
- b. time saving (from 10 days to 1 day in preparation);
- c. eco-friendly green and safe;
- d. suitable for all types of piles and test loads as well as offshore piles using autoYJACK.



YJACK Pile Test	
	
STATIC METHOD (CONVENTIONAL)	YJACK METHOD (INNOVATIVE)
Expensive	Economical
Slow and Tedious	Fast and Simple
Large Work Platform	Environmental Green
Limited Test Load	Unlimited Test Load
Not for Offshore Piles	For All Types of Piles
Dangerous	Safe



VALIDATION OBJECTIVE

The objectives of the tests were to validate the newly invented YJACK on driven concrete piles compared to conventional kentledge pile load test system in terms of:

- (1) the functionality, and
- (2) the accuracy

This YJACK Test Report presents the 4*NOS test piles installed at Project Case at Muar on 2015/OCT/10-12 with 6*NOS YJACK pile tests as following:

- Validation Phase 1: maintained load tests (MLT) on Test Pile # TOP1A & 1B, TOP2A & 2B to test load 600kN
- Validation Phase 2: quick load tests (QLT) on Test Pile # TOP1A & 1B to test load 900kN

PILE DESIGN

The Test Piles have the following pile design information based on piling record:

Pile ID	TOP1A	TOP1B	TOP2A	TOP2B
Pile Type	Spun Concrete	Spun Concrete	Spun Concrete	Spun Concrete
Pile Grade	Grade 80/Class B	Grade 80/Class B	Grade 80/Class B	Grade 80/Class B
Pile Size (mm)	300Ø	300Ø	300Ø	300Ø
Pile Area (cm ²)	452	452	452	452
Pile Make-Up	6S+0.3Y+12E+12E	6S+0.3Y+12E+12E	6S+0.3Y+12E+12E	6S+0.3Y+12E+12E
Pile Length (m)	30.3	30.3	30.3	30.3
Working Load (kN)	300	300	300	300
Test Load (kN)	600	600	600	600
Failure Load (kN)	900	900	Not Tested	Not Tested

YJACK MODEL

Based on the pile design, the following YJACK selected:

Pile ID	TOP1A	TOP1B	TOP2A	TOP2B
YCELL Model	3GYJZD150	3GYJZD150	3GYJZD150	3GYJZD150
YCELL Capacity (kN)	800	800	800	800
YCELL Area (mm ²)	11,304	11,304	11,304	11,304
YCELL Quantity (nos)	1	1	1	1
YJACK Capacity (kN)	800	800	800	800
YJACK Size (mm)	300	300	300	300
YJACK Stroke (mm)	80	80	80	80

YCELL: the single hydraulic unit prior to fabricate the YJACK

TERMINATION CRITERIA

All the Test Piles were installed by injection hammer with pile termination criteria “pile to set” (refer to pile driving criteria from the piling contractor).

PILE INSTALLATION

The design pile make-up was $6S+0.3YJACK+12E+12E = 30.3m$ (toe to top). The 1st pile joint from pile toe was installed with YJACK during the pile driving process.

The following were the site photos to illustrate the YJACK installation:



Step (1)



Step (2)



Step (3)

- Step (1):** Prefabricated YJACK arrive on site and wait for installation
- Step (2):** Spliced the YJACK at the 1st pile joint from pile toe (i.e. 6m from pile toe)
- Step (3):** Joint-welded YJACK with 12m extension pile and then continue driving

The details of the pile installations were shown in the piling record as shown in Appendix A1 (Pile Installation Record).

PILE LOCATION

All the Test Piles were installed at same location with “same” soil properties conditions as shown in the site photos below with bore-hole records as shown in Appendix A2 (Bore Hole Records).





INSTALLATION TERMINATION

All the Test Piles were installed pile to set as following:

Pile ID	TOP1A	TOP1B	TOP2A	TOP2B
Date Installed	2015/OCT/12	2015/OCT/12	2015/OCT/13	2015/OCT/13
Pile Depth (m)	27.3	27.7	27.2	26.8
Pile Set (mm/10b)	Injection Pile to Set	Injection Pile to Set	Injection Pile to Set	Injection Pile to Set

Subsequently, pile tests were carried out as described in YJACK TEST Section.

INSTALLATION BEHAVIOR

The pile installation using injection hammer on the Test Piles has similar pile installation behavior like those working piles without YJACK. No abnormality installation behavior observed. This means that the YJACK has a good impedance so that the compressive forces can transmit from pile top to pile toe and effectively past thru the YJACK location without losses of the compressive forces.

The pile installation of Test Piles did not change the mode of piling practices. The Test Piles was installed like a normal pile (without YJACK). However, there were minor interruptions of pile installation for fixing the casing pipe outside the pile for every 1.0 – 1.5m pile penetration intervals.

In summary, the Test Piles have the followings installation behavior:

- No different in installation, just install the pile like a test pile without YJACK
- Minor interruptions in pile installation due to fixing of casing pipe
- The YJACK able to resist pile bending during installation
- The YJACK able to transmit compressive forces and has enough pile impedance

YJACK TEST

After waiting period of approximately 2 months, the Test Piles were subjected to static load pile test based on YJACK bi-directional method using a maintained load test loading procedure (MLT).

The pressure increment and loading schedule presented in Appendix B (YJACK Bi-Directional Pile Load Test Loading Schedule).

The displacements of the telltales were measured in every loading steps by using manual data recording on the field sheets.

The following were the site photos to illustrate the YJACK testing using bi-directional principle:



Step 1



Step 2

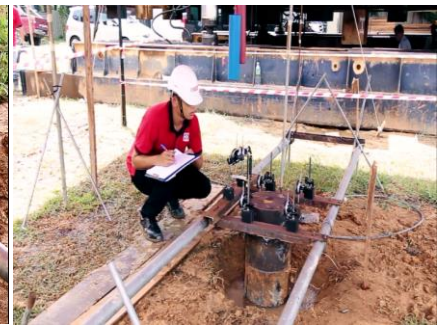

Step 3

Step 1: Reference beams setup (follow the conventional load test procedure)

Step 2: Load test setup ready, 4*dial gauges at pile top and 2*dial gauges for YJACK up/down

Step 3: Manual data recording (follow the conventional load test procedure)

PHASE 1: YJACK VALIDATION RESULTS

The YJACK test results using static maintained load test (MLT) method were presented in Appendix C1 (YJACK Bi-Directional Pile Load Test Results using MLT).

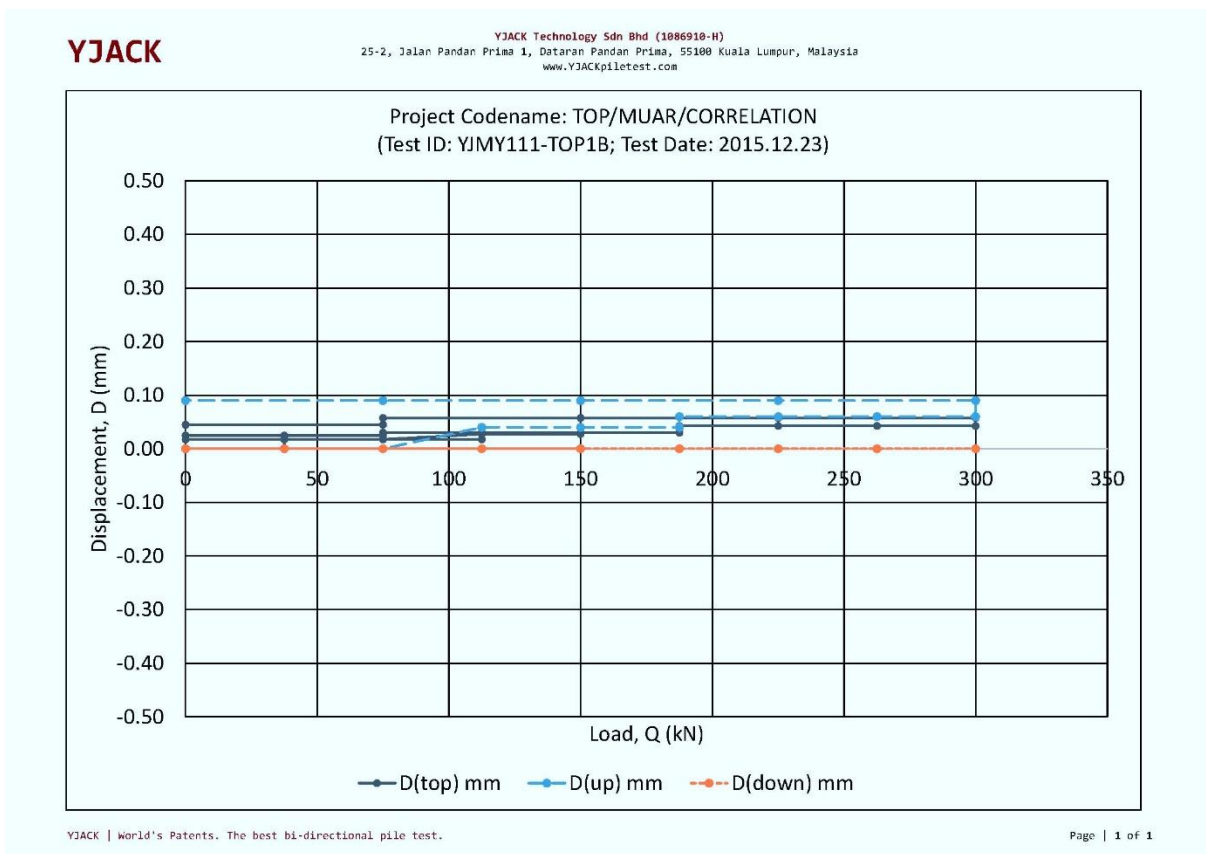
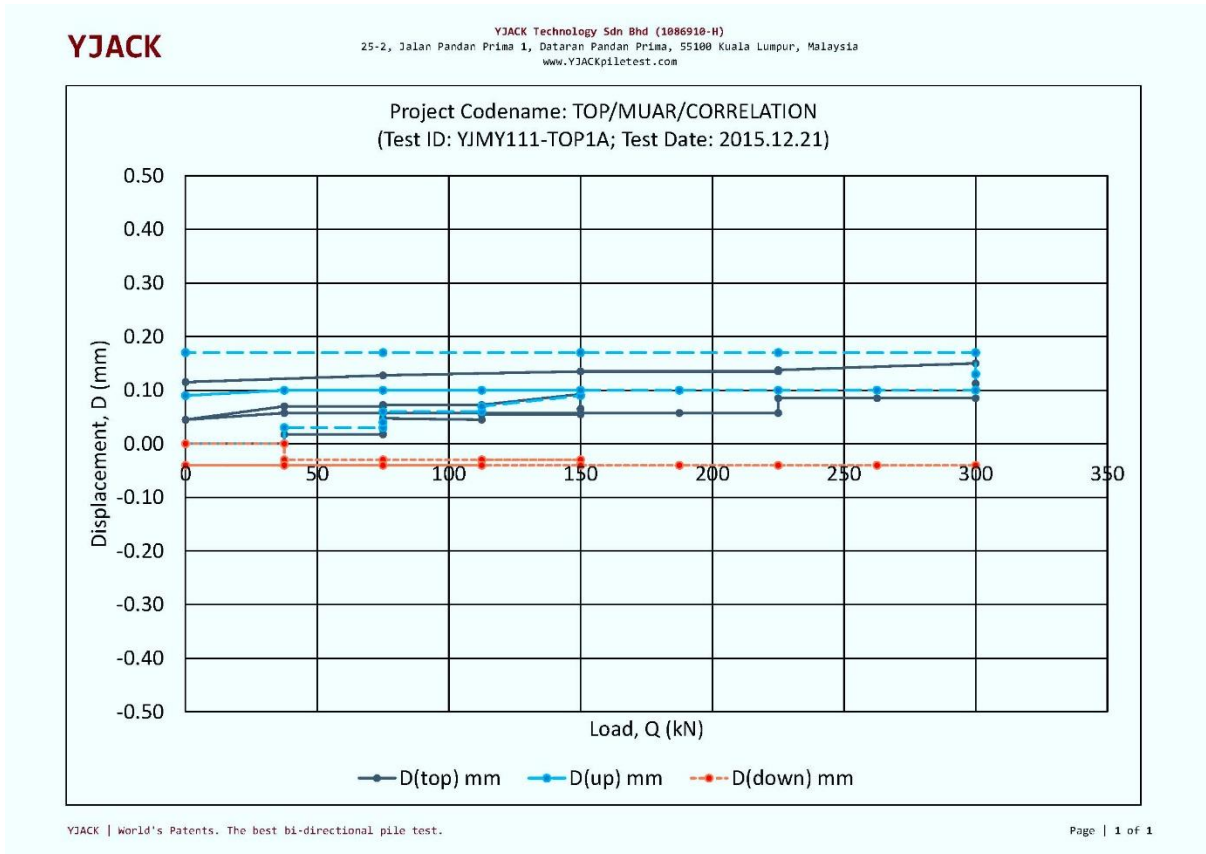

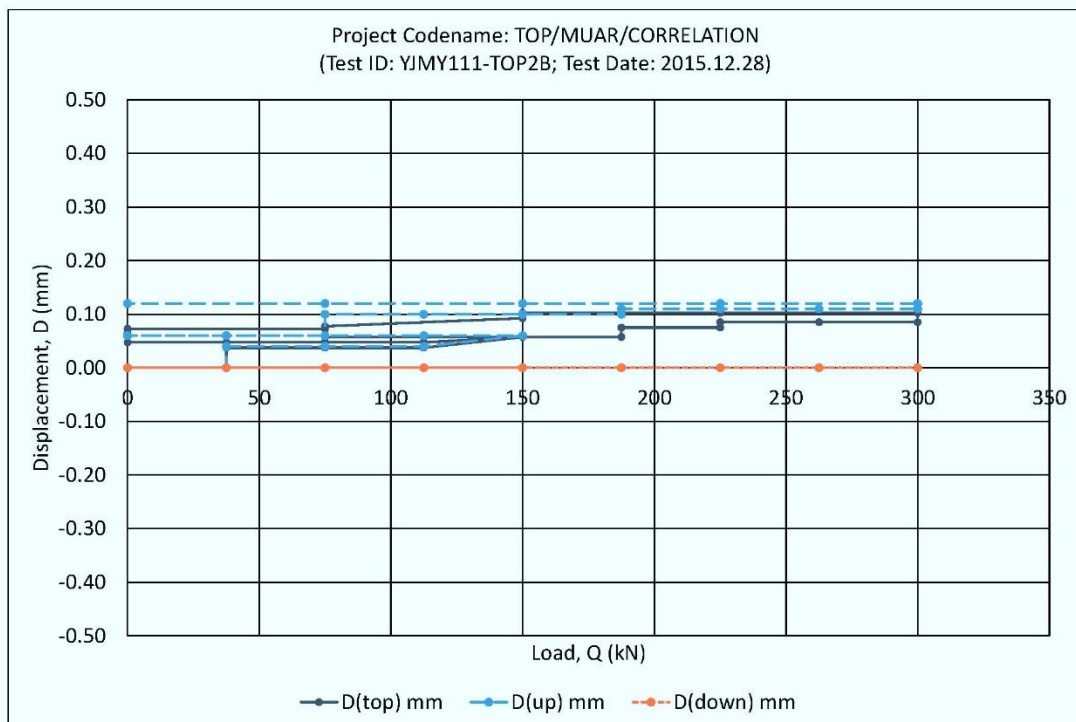
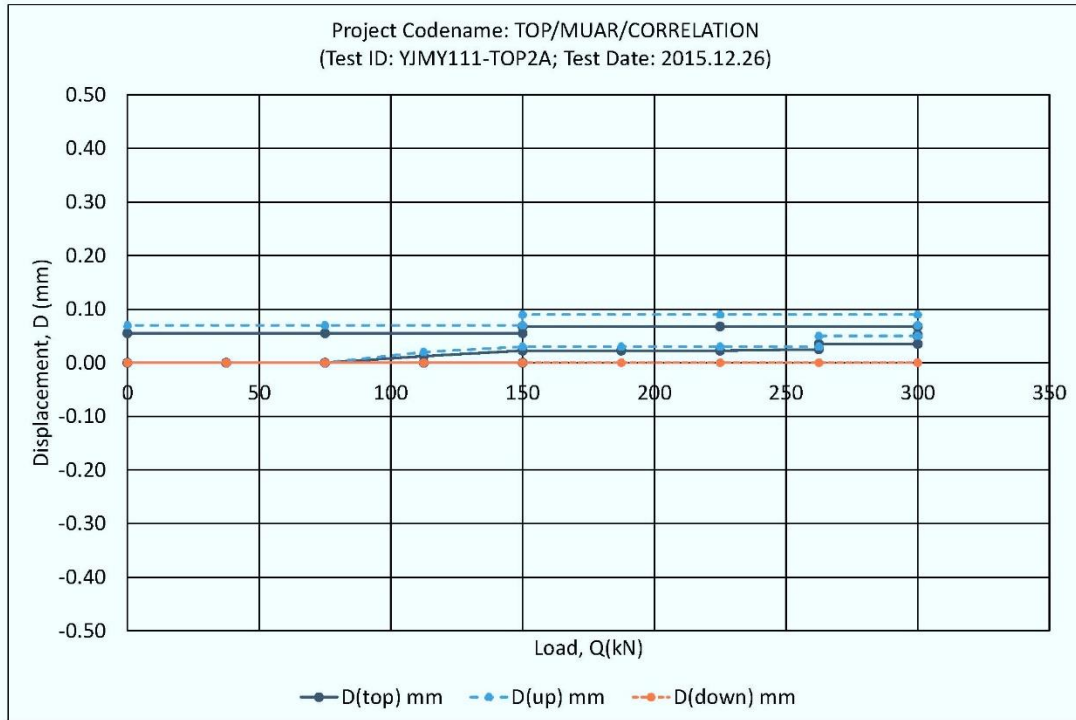

The following is the summary test results based on YJACK MLT Method:

Pile ID	TOP1A	TOP1B	TOP2A	TOP2B
Skin Friction at Top Section (kN) *	300	300	300	300
Skin friction at Bottom Section + Base Bearing (kN) #	300	300	300	300
Total Pile Load Capacity in Full Section (kN)	600	600	600	600
Gap Opening after Removal Working Load 300kN (mm)	0.13	0.02	0.01	0.06
Gap Opening after Removal Test Load 600kN (mm)	0.21	0.09	0.07	0.12

* top skin friction not failure with applied load well maintained in 24 hours loading

base bearing not failure with permanent displacement < 15mm (= assumed 5% of pile diameter)

The following is the determination of the pile ultimate load by consideration of the tension over compression factor:

Pile ID	TOP1A	TOP1B	TOP2A	TOP2B
Corrected Skin Friction at Top Section (kN) *	300/γ	300/γ	300/γ	300/γ
Corrected Skin Friction at Top Section (kN)	375	375	375	375
Corrected Total Pile Load Capacity in Full Section (kN)	675	675	675	675
Pile Weight at Top Section (kN) #	25	25	25	25
Ultimate Pile Load Capacity in Full Section (kN)	650	650	650	650
Accepted Ultimate Capacity in Full Section (kN)	> 600 (OK!)	> 600 (OK!)	> 600 (OK!)	> 600 (OK!)

* use tension over compression factor, γ = 0.8 for cohesive material

pile weight at pile top section = pile area x pile length at top section x pile density = about 25kN

The following is the summary test results based on top loaded Q-s Plot in accordance to Singapore Standard SS/CP4:

Pile ID	TOP1A	TOP1B	TOP2A	TOP2B
Top-Loaded Pile Load Capacity (kN)	600	600	600	600
Top-Loaded Settlement at Working Load 300kN (mm)	2.8	2.8	2.7	2.6
Top-Loaded Settlement at Test Load 600kN (mm)	5.6	5.7	5.6	5.4

The following is the test acceptance in accordance to Malaysian JKR Specifications JKR/20800 (2014):

Pile ID	TOP1A	TOP1B	TOP2A	TOP2B
Accepted Top-Loaded Pile Load Capacity (kN)	> 600 (OK!)	> 600 (OK!)	> 600 (OK!)	> 600 (OK!)
Accepted Top-Loaded Settlement at Working Load (mm)	< 12.5 (OK!)	< 12.5 (OK!)	< 12.5 (OK!)	< 12.5 (OK!)
Accepted Top-Loaded Settlement at Test Load (mm)	< 38.0 (OK!)	< 38.0 (OK!)	< 38.0 (OK!)	< 38.0 (OK!)
Accepted Residual Settlement *	< 6.5 (OK!)	< 6.5 (OK!)	< 6.5 (OK!)	< 6.5 (OK!)

* Pile-soil interaction of residual settlement assumed to be similar to gap opening after removal working load.



Test Comments:

- the YJACK gap opening after removal of the working load is very small, this small gap opening equivalent to residual settlement in conventional maintained load test with the pile head almost fully rebound.
- the ultimate load of 650kN is deemed to be conservative and there is no requirement to do pile restrike to close the such a small gap opening of 0.2mm, hence the test piles can be further to be designed as working piles.

PHASE 1: YJACK VALIDATION CORRELATIONS

All the Test Piles were tested by using kentledge method and YJACK method based on maintained load test (MLT) procedure.

The MLT load tests were carried out by kentledge followed by YJACK method on the same piles as follows:

Pile ID	TOP1A	TOP1B	TOP2A	TOP2B
Kentledge Test	2015/DEC/16	2015/DEC/18	2015/DEC/23	2015/DEC/25
YJACK Test	2015/DEC/21	2015/DEC/23	2015/DEC/26	2015/DEC/28

The kentledge load tests were performed by using the injection machines as the reaction system.

The following site photos to show the load test setup comparisons:



The correlation results are shown in following pages.

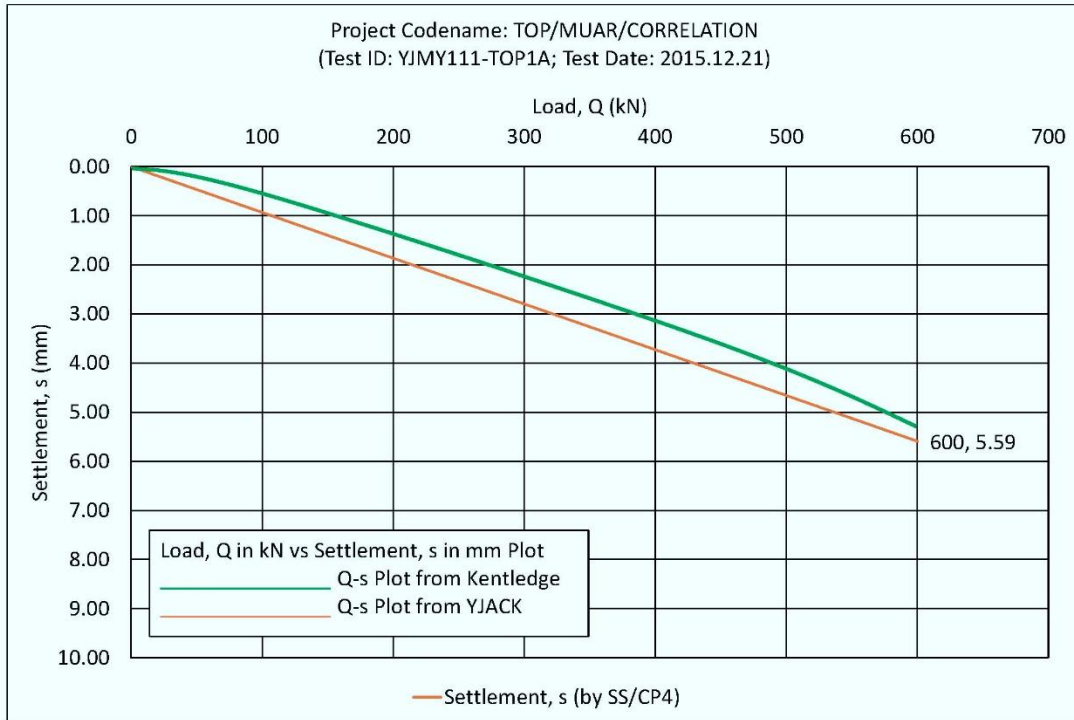

Correlation Method # 1

The following is the correlation using MLT settlement at working and test loads as the correlation base data:

Correlation Data Point	Working Load *	Settlement At 300kN	Test Load *	Settlement At 600kN
Kentledge Method	300	2.3	600	5.3
YJACK Method	300	2.8	600	5.6
Percentage Error #	0.0%	17.9%	0.0%	5.4%
Average Accuracy	94.2%			

* The loads were measured by same pressure system. Both system have same loading accuracies.

Percentage Error = (measured - published) / published, in absolute values

Correlation Method # 2

The following is the correlation using acceptable settlement at working and test loads as the correlation base data:

Correlation Data Point	Working Load *	Settlement Limit 12.5	Test Load *	Settlement Limit 38.0
Kentledge Method	300	10.2	600	32.7
YJACK Method	300	9.7	600	32.4
Percentage Error #	0.0%	5.2%	0.0%	0.9%
Average Accuracy	98.5%			

* The loads were measured by same pressure system. Both system have same loading accuracies.

Percentage Error = (measured - published) / published, in absolute values

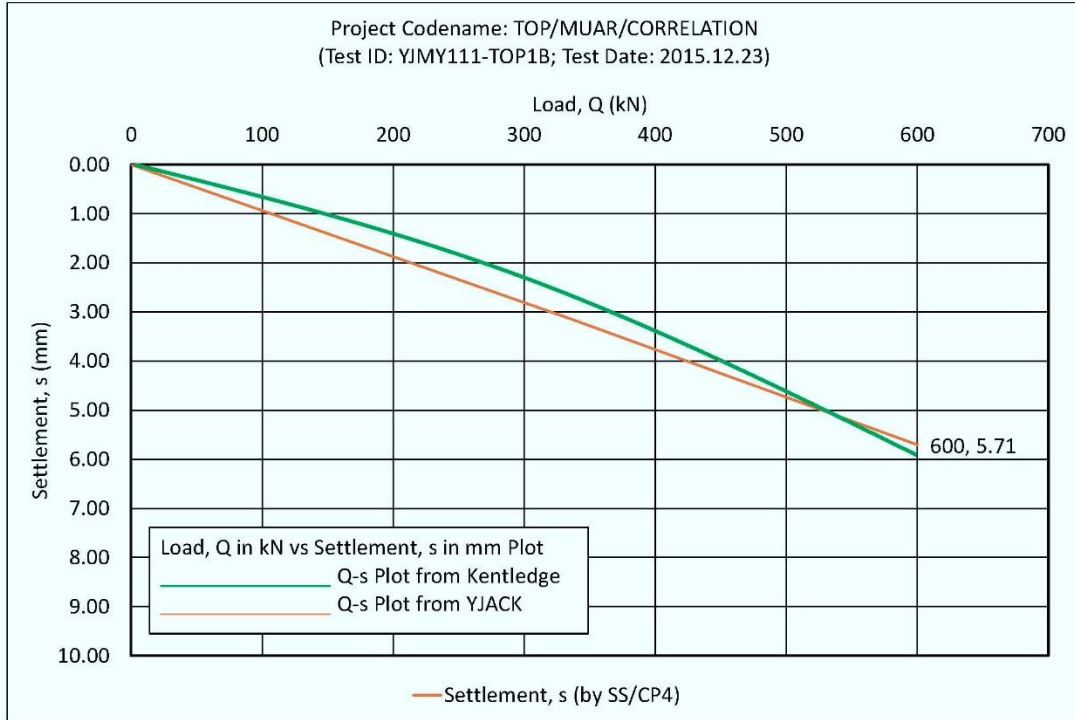

Correlation Method # 1

The following is the correlation using MLT settlement at working and test loads as the correlation base data:

Correlation Data Point	Working Load *	Settlement At 300kN	Test Load *	Settlement At 600kN
Kentledge Method	300	2.3	600	5.9
YJACK Method	300	2.8	600	5.7
Percentage Error #	0.0%	17.9%	0.0%	3.5%
Average Accuracy	94.7%			

* The loads were measured by same pressure system. Both system have same loading accuracies.

Percentage Error = (measured - published) / published, in absolute values

Correlation Method # 1

The following is the correlation using acceptable settlement at working and test loads as the correlation base data:

Correlation Data Point	Working Load *	Settlement Limit 12.5	Test Load *	Settlement Limit 38.0
Kentledge Method	300	10.2	600	32.1
YJACK Method	300	9.7	600	32.3
Percentage Error #	0.0%	5.2%	0.0%	0.6%
Average Accuracy	98.6%			

* The loads were measured by same pressure system. Both system have same loading accuracies.

Percentage Error = (measured - published) / published, in absolute values

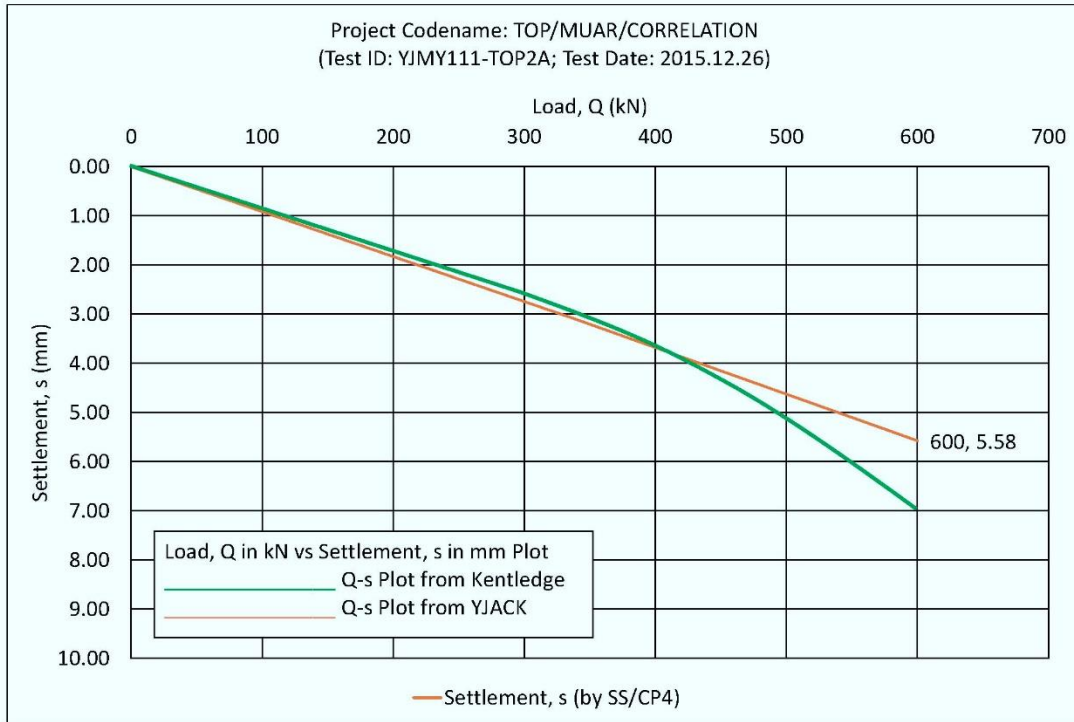

Correlation Method # 1

The following is the correlation using MLT settlement at working and test loads as the correlation base data:

Correlation Data Point	Working Load *	Settlement At 300kN	Test Load *	Settlement At 600kN
Kentledge Method	300	2.6	600	6.9
YJACK Method	300	2.7	600	5.6
Percentage Error #	0.0%	3.7%	0.0%	23.2%
Average Accuracy	93.3%			

* The loads were measured by same pressure system. Both system have same loading accuracies.

Percentage Error = (measured - published) / published, in absolute values

Correlation Method # 2

The following is the correlation using acceptable settlement at working and test loads as the correlation base data:

Correlation Data Point	Working Load *	Settlement Limit 12.5	Test Load *	Settlement Limit 38.0
Kentledge Method	300	9.9	600	31.1
YJACK Method	300	9.8	600	32.4
Percentage Error #	0.0%	1.0%	0.0%	4.0%
Average Accuracy	98.8%			

* The loads were measured by same pressure system. Both system have same loading accuracies.

Percentage Error = (measured - published) / published, in absolute values

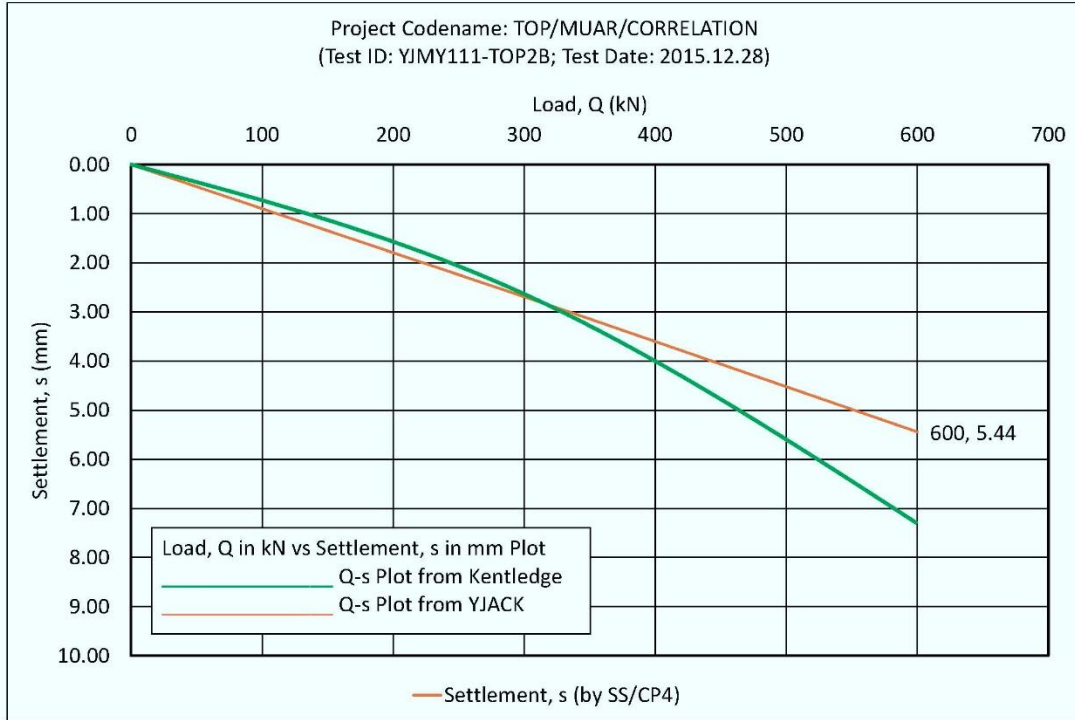

Correlation Method # 1

The following is the correlation using MLT settlement at working and test loads as the correlation base data:

Correlation Data Point	Working Load *	Settlement At 300kN	Test Load *	Settlement At 600kN
Kentledge Method	300	2.6	600	7.3
YJACK Method	300	2.6	600	5.4
Percentage Error #	0.0%	0.0%	0.0%	35.2%
Average Accuracy	91.2%			

* The loads were measured by same pressure system. Both system have same loading accuracies.

Percentage Error = (measured - published) / published, in absolute values

Correlation Method # 2

The following is the correlation using acceptable settlement at working and test loads as the correlation base data:

Correlation Data Point	Working Load *	Settlement Limit 12.5	Test Load *	Settlement Limit 38.0
Kentledge Method	300	9.9	600	30.7
YJACK Method	300	9.9	600	32.6
Percentage Error #	0.0%	0.0%	0.0%	5.8%
Average Accuracy	98.6%			

* The loads were measured by same pressure system. Both system have same loading accuracies.

Percentage Error = (measured - published) / published, in absolute values

PHASE 2: YJACK VALIDATION RESULTS

In addition to MLT static pile load test, subsequent load tests were carried out on TOP1A and TOP1B using quick load test (QLT) and the results were presented in Appendix C2 (YJACK Bi-Directional Pile Load Test Results using QLT).

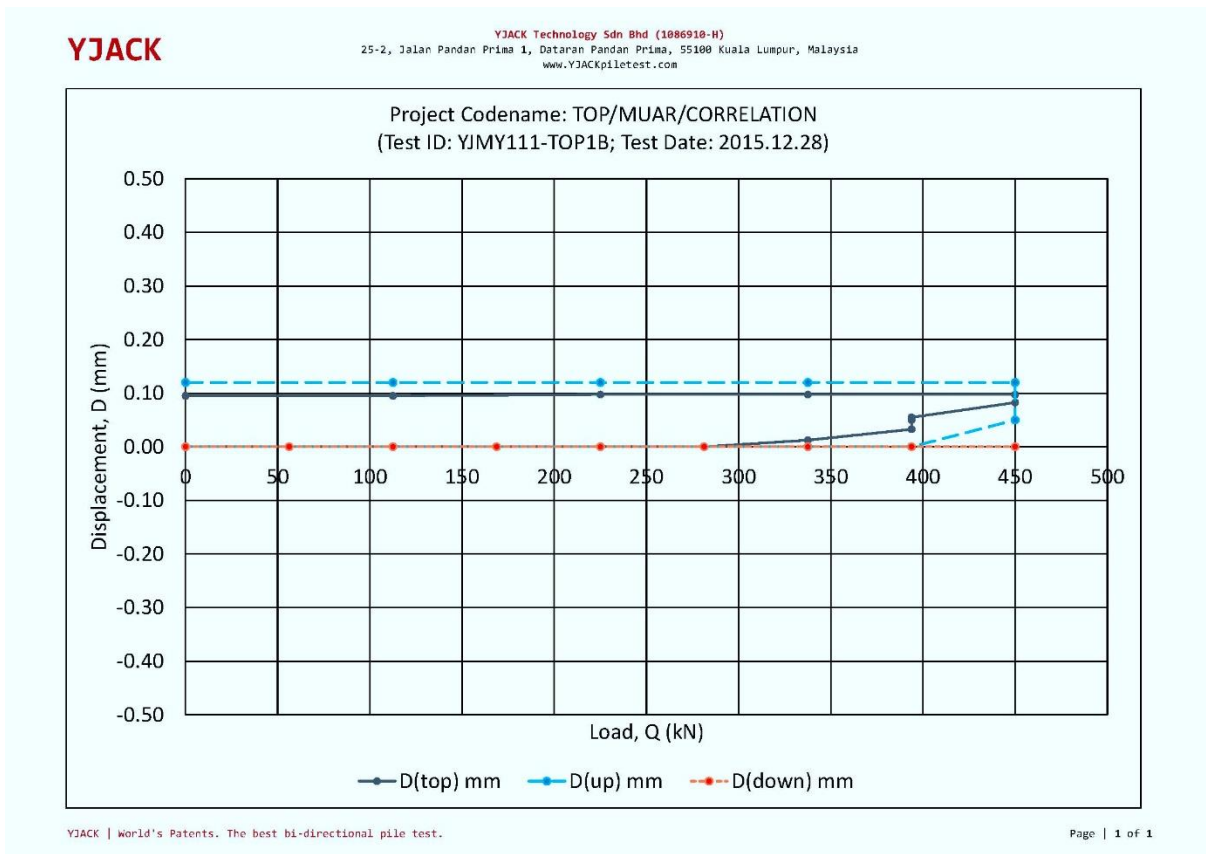
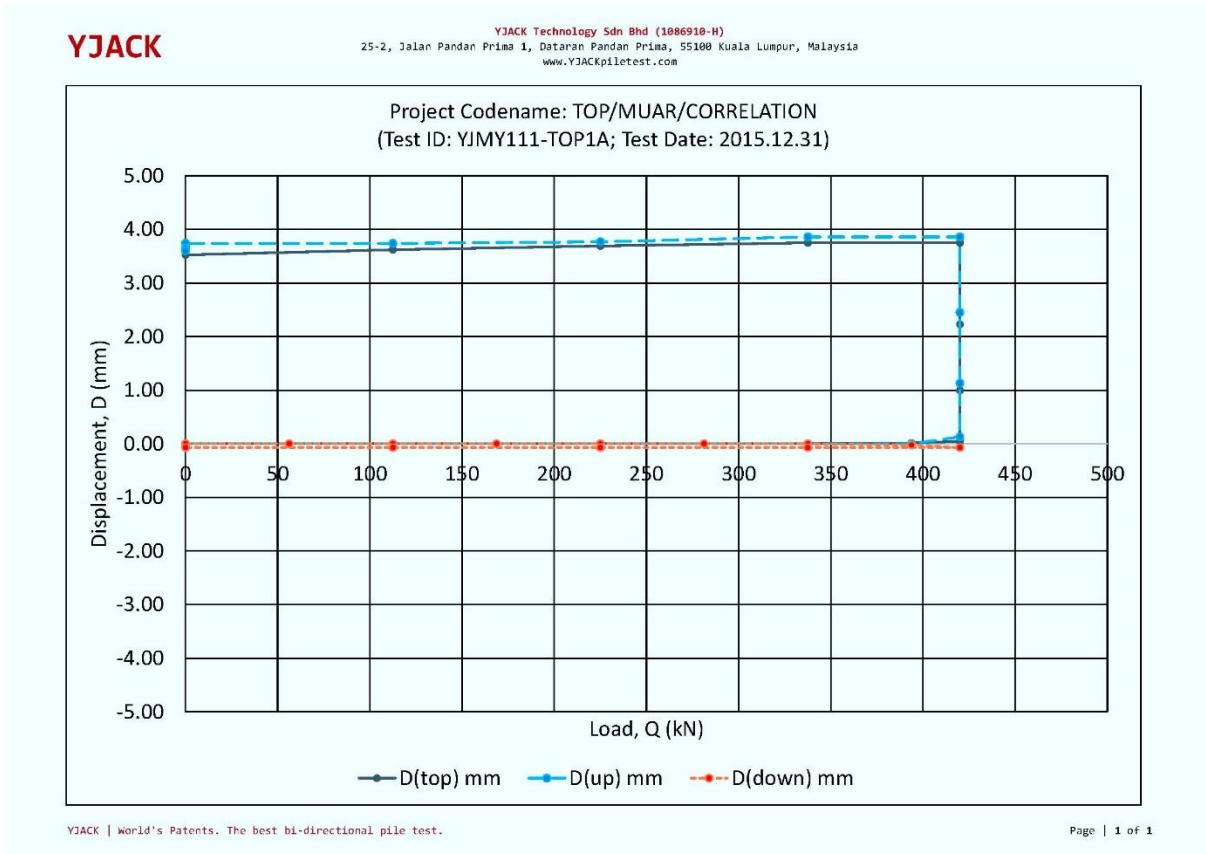

The following is the summary test results based on YJACK QLT Method:

Pile ID	TOP1A	TOP1B	TOP2A	TOP2B
Skin Friction at Top Section (kN) *	420	450	Not Tested	Not Tested
Skin friction at Bottom Section + Base Bearing (kN) #	450	450	Not Tested	Not Tested
Total Pile Load Capacity in Full Section (kN)	870	900	Not Tested	Not Tested

* top skin friction failure with load unable maintained

base bearing not failure with permanent displacement < 15mm (= assumed 5% of pile diameter)

The following is the determination of the pile ultimate load by consideration of the tension over compression factor:

Pile ID	TOP1A	TOP1B	TOP2A	TOP2B
Corrected Skin Friction at Top Section (kN) *	$420/\gamma$	$450/\gamma$	Not Tested	Not Tested
Corrected Skin Friction at Top Section (kN)	525	560	Not Tested	Not Tested
Extrapolated Pile Capacity at Bottom Section (kN)	30	0	Not Tested	Not Tested
Corrected Total Pile Load Capacity in Full Section (kN)	1005	1010	Not Tested	Not Tested
Pile Weight at Top Section (kN) #	25	25	Not Tested	Not Tested
Ultimate Pile Load Capacity in Full Section (kN)	980	985	Not Tested	Not Tested
Accepted Ultimate Capacity in Full Section (kN)	> 900 (OK!)	> 900 (OK!)	Not Tested	Not Tested

* use tension over compression factor, $\gamma = 0.8$ for cohesive material

* pile weight at pile top section = pile area x pile length at top section x pile density = approx. 25kN

The following is the summary test results based on top loaded Q-s Plot in accordance to Singapore Standard SS/CP4:

Pile ID	TOP1A	TOP1B	TOP2A	TOP2B
Top-Loaded Pile Load Capacity (kN)	900	900	Not Tested	Not Tested
Top-Loaded Settlement at Working Load 300kN (mm)	2.9	2.9	Not Tested	Not Tested
Top-Loaded Settlement at Test Load 600kN (mm)	5.5	5.6	Not Tested	Not Tested
Top-Loaded Settlement at Test Load 900kN (mm)	9.8	8.5	Not Tested	Not Tested

The following is the test acceptance in accordance to Malaysian JKR Specifications JKR/20800 (2014):

Pile ID	TOP1A	TOP1B	TOP2A	TOP2B
Accepted Top-Loaded Pile Load Capacity (kN)	> 900 (OK!)	> 900 (OK!)	Not Tested	Not Tested
Accepted Top-Loaded Settlement at Working Load (mm)	< 12.5 (OK!)	< 12.5 (OK!)	Not Tested	Not Tested
Accepted Top-Loaded Settlement at Test Load (mm)	< 38.0 (OK!)	< 38.0 (OK!)	Not Tested	Not Tested
Accepted Top-Loaded Settlement at Failure Load (mm)	< 76.0 (OK!)	< 76.0 (OK!)	Not Tested	Not Tested

* Assumed acceptable settlement at 3X Working Load = 76mm (3 inch).



Test Comments:

- the residual settlements were not considered due to quick load test procedure with 1 cycle loading up to failure load of 900kN (= 3X working load).
- the top section of the Test Pile # TOP1A only achieve ultimate load of 420kN and unable to achieve test load of 450, however the pile capacity bottom section deems to be conservative with very small displacement, hence by extrapolated the bottom section from 450 to 480kN, to construct the equivalent Q-s Plot to obtain 4900kN (= 420 + 480).



PHASE 2: YJACK VALIDATION CORRELATIONS

In additional to Phase 1 Correlations, subsequent load tests were carried out on Test Piles # TOP1A and TOP1B for failure load tests based on quick load test (QLT) procedure.

The QLT load tests were carried out by kentledge followed by YJACK Method on the same piles as follows:

Pile ID	TOP1A	TOP1B	TOP2A	TOP2B
Kentledge Failure	2015/DEC/25	2015/DEC/26	No Tested	No Tested
YJACK Failure	2015/DEC/31	2015/DEC/28	No Tested	No Tested

The correlation results are shown in following pages.

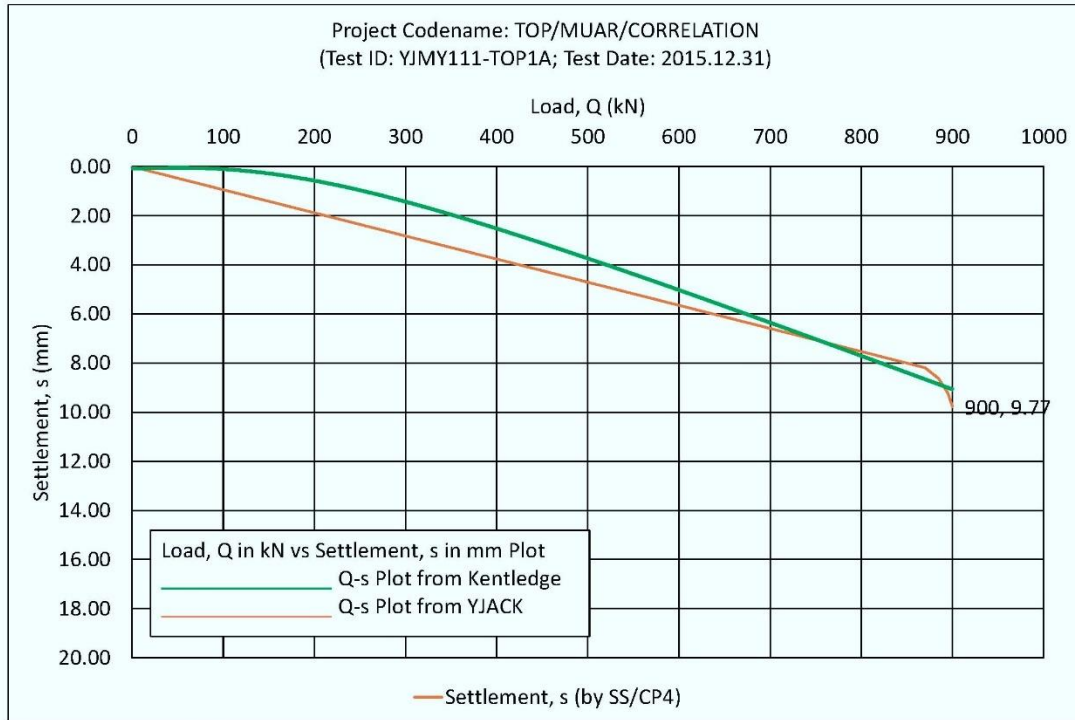

Correlation Method # 1

The following is the correlation using MLT settlement at working and test loads as the correlation base data:

Correlation Data Point	Working Load *	Settlement At 300kN	Test Load *	Settlement At 600kN	Failure Load *	Settlement At 900kN
Kentledge Method	300	1.2	600	5.0	900	9.0
YJACK Method	300	2.9	600	5.5	900	9.8
Percentage Error #	0.0%	58.6%	0.0%	9.1%	0.0%	8.2%
Average Accuracy	87.4%					

* The loads were measured by same pressure system. Both system have same loading accuracies.

Percentage Error = (measured - published) / published, in absolute values

Correlation Method # 2

The following is the correlation using acceptable settlement at working and test loads as the correlation base data:

Correlation Data Point	Working Load *	Settlement Limit 12.5	Test Load *	Settlement Limit 38.0	Failure Load *	Settlement Limit 76.0
Kentledge Method	300	11.3	600	33.0	900	67.0
YJACK Method	300	9.6	600	32.5	900	66.2
Percentage Error #	0.0%	17.7%	0.0%	1.5%	0.0%	1.2%
Average Accuracy	96.6%					

* The loads were measured by same pressure system. Both system have same loading accuracies.

Percentage Error = (measured - published) / published, in absolute values

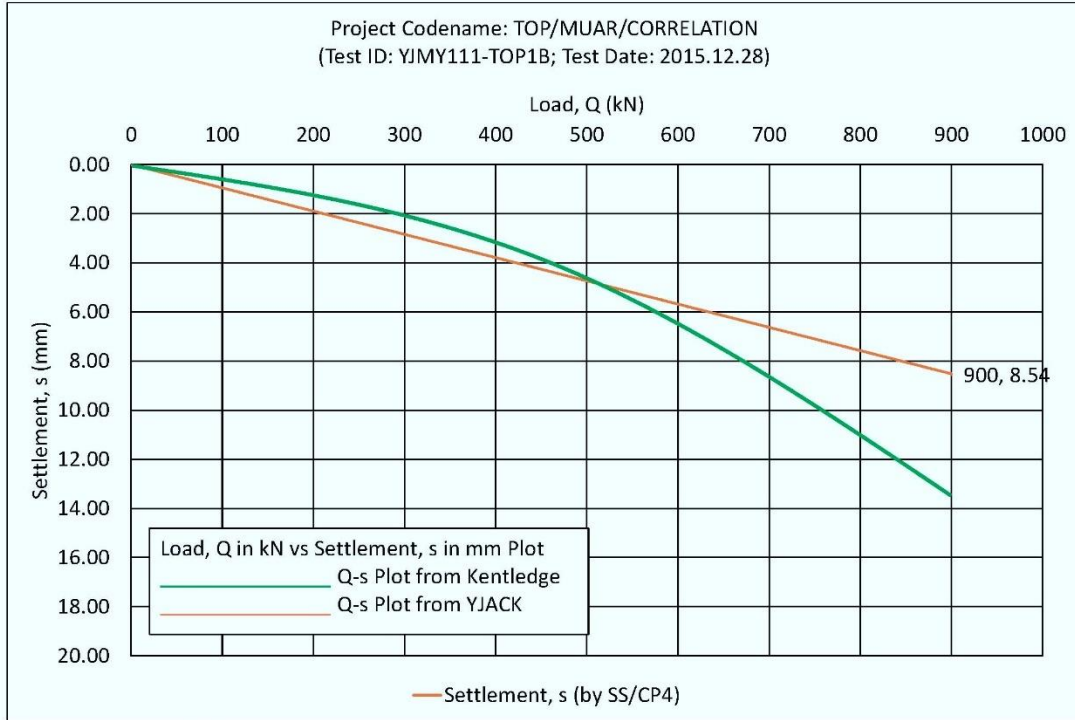

Correlation Method # 1

The following is the correlation using MLT settlement at working and test loads as the correlation base data:

Correlation Data Point	Working Load *	Settlement At 300kN	Test Load *	Settlement At 600kN	Failure Load *	Settlement At 900kN
Kentledge Method	300	2.1	600	6.5	900	13.4
YJACK Method	300	2.9	600	5.6	900	8.5
Percentage Error #	0.0%	27.6%	0.0%	16.1%	0.0%	57.6%
Average Accuracy	83.1%					

* The loads were measured by same pressure system. Both system have same loading accuracies.

Percentage Error = (measured - published) / published, in absolute values

Correlation Method # 2

The following is the correlation using acceptable settlement at working and test loads as the correlation base data:

Correlation Data Point	Working Load *	Settlement Limit 12.5	Test Load *	Settlement Limit 38.0	Failure Load *	Settlement Limit 76.0
Kentledge Method	300	10.4	600	31.5	900	62.6
YJACK Method	300	9.6	600	32.4	900	67.5
Percentage Error #	0.0%	8.3%	0.0%	2.8%	0.0%	7.3%
Average Accuracy	96.9%					

* The loads were measured by same pressure system. Both system have same loading accuracies.

Percentage Error = (measured - published) / published, in absolute values



CORRELARION SUMMARY

The following is the summary of the correlation results obtained from Correlation Phase 1 and Phase 2.

Correlation Method # 1

The following is the correlation using load test settlement at working and test loads as the correlation base data:

Pile ID	TOP1A	TOP1B	TOP2A	TOP2B	TOP1A	TOP1B
Loading Procedure	MLT	MLT	MLT	MLT	QLT	QLT
Average Accuracy	94.2%	94.7%	93.3%	91.2%	87.4%	83.1%
Accuracy Level *	High	High	High	High	High	High
Average Accuracy	90.7%					

* High if Accuracy \geq 80%; Moderate if 50% > Accuracy < 80%; Low if Accuracy \leq 50%

Correlation Method # 2

The following is the correlation using acceptable settlement at working and test loads as the correlation base data:

Pile ID	TOP1A	TOP1B	TOP2A	TOP2B	TOP1A	TOP1B
Loading Procedure	MLT	MLT	MLT	MLT	QLT	QLT
Average Accuracy	98.5%	98.6%	98.8%	98.6%	96.6%	96.9%
Accuracy Level *	High	High	High	High	High	High
Average Accuracy	98.0%					

* High if Accuracy \geq 80%; Moderate if 50% > Accuracy < 80%; Low if Accuracy \leq 50%



VALIDATION CONCLUSION

The following is the validation conclusions for functionality and accuracy of the newly invented YJACK.

(1) Validation for the functionality of the YJACK

The pile installation using injection hammer on the 4*NOS Test Piles has similar pile installation behavior like those working piles without YJACK. No abnormality installation behavior observed with the followings installation behavior:

- No different in installation, just install the pile like a test pile without YJACK
- Minor interruptions in pile installation due to fixing of casing pipe
- The YJACK able to resist pile bending during installation
- The YJACK able to transmit compressive forces and has enough pile impedance

The pile testing also demonstrated the YJACK can perform well under load pressurizations from 0 to 300 (working load) to 600 (test load) to 900kN (failure load). No any hydraulic jack interlocking observed during loading and unloading procedures.

In conclusion, the YJACKs are fully performed well in terms of functionality in installation and testing.

(2) Validation for the accuracy of the YJACK

The correlation summary on 6*NOS YJACK pile tests indicated extremely high accuracy more than 95% with the following correlation studies:

- Validation Phase 1: 4*NOS YJACK pile tests based on maintained load test method (MLT) up to 600kN
- Validation Phase 2: 2*NOS YJACK pile tests based on quick load test method (QLT) up to 900kN

YJACK is a hydraulic jack system, the same to conventional load test which also using hydraulic jack in pressure loading measurements. Hence, both YJACK and kentledge loads were measured by the same pressure systems with same loading accuracies, i.e. 100%.

In the load-settlement behavior plots for kentledge and YJACK, both indicated similar patterns with accuracy range higher than 80%, in which this is deemed to be high level accuracy in correlation studies.

In conclusion, the YJACKs are fully performed well in terms of accuracy of ultimate (i.e. the load) and serviceability (i.e. settlement) design considerations.

APPENDIX A1



JABATAN KERJA RAYA MALAYSIA
REKOD PENANAMAN CERUCUK

KONTRAKTOR : ALIAH ENTERPRISE.

SHEET NO: 1

NO. KONTRAK : JKR/PERS/J/M/01/2014

DATE: 13 / 10 / 15

PROJECT: MEMBINA & MENYIAPKAN SEBUAH (1) GELANGGANG SERBAGUNA TERBUKA DLL DI SMK SG.ABONG	
PILE NO./LOCATION: <u>TP-2-B</u>	
PILE TYPE: <u>300X300 m</u>	SIZE:
PILE PIRCHED LENGTH: <u>6+12+12 = 6+0.375JACK+12+12</u>	TOTAL PENETRATION: <u>26.8 m</u>
PILE PAID LENGTH	NO. OF JOINTS: <u>3</u>
JACK MODEL / RAMP AREA:	FINAL SET:
CUT OFF PILE HEAD:	YES: NO:
DATE CASTING/REF:	
PILE LENGTH USED:	
JACKED TIME:	

REMARKS	M	Mpa	M	Mpa	M	Mpa	M	Mpa	M	Mpa	M	Mpa
	1	6	7	2	13	3	19	7	25	10	31	
						4		8		11		
						7		7		10		
	2		8		14		20	7	26	11	32	
								0		12		
								1		12		
	3		9		15		21		27	13	33	2 = 0.11 m
										13		
										13		
	4		10		16		22		28		34	
		2		2								
	5		11		17	4	23	0	29		35	
						5		7				
						6		1				
	6		12		18	5	24	2	30		36	
						6		4				
						7		9				

DISAHKAN OLEH:

Teknikawan S.
(WAKIL KONTRAKTOR)

ISMAIL JAUHARI B. MOHD TAPPRIZI

H/P: 012-6389312

ALIAH ENTERPRISE
Penyedia Tapak

(WAKIL JKR)

af
DORLIZA ABUULLAH
PEN. JURUTERA SAZD
JKR. MUAR

Jimmy Wui



JABATAN KERJA RAYA MALAYSIA
REKOD PENANAMAN CERUCUK

KONTRAKTOR : ALIAH ENTERPRISE.

SHEET NO: 1

NO. KONTRAK : JKR/PERS/J/M/01/2014

DATE: 13 / 10 / 15

PROJECT: MEMBINA & MENYIAPKAN SEBUAH (1) GELANGGANG SERBAGUNA TERBUKA DLL DI SMK SG.ABONG	
PILE NO./LOCATION: TP-2A	
PILE TYPE: 300x300M	SIZE:
PILE PIRCHED LENGTH: 6+12+12-6 to 3 JACK+12	TOTAL PENETRATION: 27-30M
PILE PAID LENGTH +12.	NO. OF JOINTS: 3
JACK MODEL / RAMP AREA:	FINAL SET:
CUT OFF PILE HEAD: YES: NO:	
DATE CASTING/REF:	
PILE LENGTH USED:	
JACKED TIME:	

REMARKS	M	Mpa	M	Mpa	M	Mpa	M	Mpa	M	Mpa	M	Mpa
	1	0	7	2	13	3	19	4	25	7	31	
				3				5		8		
				2				4		2		
	2		8		14		20		26	9	32	
										10		
										11		
	3	0	9		15		21		27-	12.		
										13	33	inlets
										50		
	4	2	10		16	3	22		28		34	
						3		4				
				2		4		5				
	5		11	3	17	3	23	7	29		35	
				2		4		6				
								7				
	6	0	12		18		24	6	30		36	
		2						1				

DISAHKAN OLEH:

T. M. N. S. S. S.
(WAKIL KONTRAKTOR)

ISMAIL JAUHARI B. MOHD TAPPRIZI
H/P: 012-6389312
ALIAH ENTERPRISE
Penyelia Tapak

(WAKIL JKR)

Jimmy Wai



JABATAN KERJA RAYA MALAYSIA
REKOD PENANAMAN CERUCUK

KONTRAKTOR : ALIAH ENTERPRISE.

SHEET NO: 1

NO. KONTRAK : JKR/PERS/J/M/01/2014

DATE: 12/10/15

PROJECT: MEMBINA & MENYIAPKAN SEBUAH (1) GELANGGANG SERBAGUNA TERBUKA DLL DI SMK SG.ABONG	
PILE NO./LOCATION: <u>TP-1A</u>	
PILE TYPE: <u>300x300</u>	SIZE:
PILE PIRCHED LENGTH: <u>6+12+12-3m 6+0.35AKK+12</u>	TOTAL PENETRATION: <u>27-7m</u>
PILE PAID LENGTH <u>+12.3</u>	NO. OF JOINTS: <u>3</u>
JACK MODEL / RAMP AREA:	FINAL SET:
CUT OFF PILE HEAD: YES: NO:	
DATE CASTING/REF:	
PILE LENGTH USED:	
JACKED TIME:	

REMARKS	M	Mpa	M	Mpa	M	Mpa	M	Mpa	M	Mpa	M	Mpa
	1	2	7	0	13	2	19	4	25	7	31	
						2				2		
	2		8		14	2	20		26	4	32	
										8		
	3		9	0	15		21		27	10	33	
								5		11		
	4		10		16	3	22	7	28	12	34	
						4		1		13		
								3		50		
	5		11		17		23	6	29		35	
	6		12		18	3	24	7	30		36	
						4		7				
						4		7				

DISAHKAN OLEH:

Talk Mohd S
(WAKIL KONTRAKTOR)

ISMAIL JAUHARI B. MOHD TAPPRIZI
H/P: 012-6389312
ALIAH ENTERPRISE
Penyelia Tapak

MOORLIZA ABDULLAH
PEN. JURUTERA JAZS
J.K.R. MUAR
(WAKIL JKR)

Jimmy Wai



JABATAN KERJA RAYA MALAYSIA
REKOD PENANAMAN CERUCUK

KONTRAKTOR : ALIAH ENTERPRISE.

SHEET NO: 1

NO. KONTRAK : JKR/PERS/JJ/M/01/2014

DATE: 12/10/15

PROJECT: MEMBINA & MENYIAPKAN SEBUAH (1) GELANGGANG SERBAGUNA TERBUKA DLL DI SMK SG.ABONG	
PILE NO./LOCATION: <u>TP 1A</u>	
PILE TYPE: <u>300φ</u>	SIZE:
PILE PIRCHED LENGTH: <u>6+12+12m 6+0.31JACK</u>	TOTAL PENETRATION: <u>27.30M</u>
PILE PAID LENGTH: <u>+12+12</u>	NO. OF JOINTS: <u>3</u>
JACK MODEL / RAMP AREA:	FINAL SET:
CUT OFF PILE HEAD: YES: NO:	
DATE CASTING/REF:	
PILE LENGTH USED:	
JACKED TIME:	

REMARKS	M	Mpa	M	Mpa	M	Mpa	M	Mpa	M	Mpa	M	Mpa
				2		3		5		7		9
	1		7	3	13		19	7	25	7	31	
				2				6		8		
	2		8		14		20		26	9	32	
								5		9		
	3		9		15		21		27	10	33	
										11		
										12		
	4		10		16		22	7	28	13	34	
				2		4		7				
				2		4		6				
	5		11	3	17		23	7	29		35	
				4				7				
				3				7				
	6		12	4	18		24	7	30		36	
				4		5		7				
				2								

DISAHKAN OLEH:

Talwin S
(WAKIL KONTRAKTOR)

ISMAIL JAUHARI B. MOHD TAPPRIZI
H/P: 012-6389312
ALIAH ENTERPRISE
Penyelias Tapak

W
(WAKIL JKR)
NOORLIZA ABDULLAH
PEN. JURUTERA JA29
J.K.R. MUAR

h
Jimmy Wai

01137619062
011376

APPENDIX A2

Bore-Hole Records / SI Report

Thick documents. Will be furnished upon request.

APPENDIX B

Cylonix

Project: Maintain Load Test @ Muar

LOADING SEQUENCE FOR WORKING TEST PILE 300mm diam. Spun Pile (WORKING LOAD = 30T)

The Load Test sequence shall generally be in accordance with BS 8004, 1986-British Standard Code of Practice for foundation.

Acting Cylinder = 200 Tonne
Ram Area = 41.22 in²

The stages of loading shall generally be as follow:

Load Percentage (%)	Tons	PSI	Minimum Time of Holding Load
1st Cycle	0	0.0	0
	25	7.5	402
	50	15.0	803
	75	22.5	1204
	100	30.0	1605
	75	22.5	1204
	50	15.0	803
	25	7.5	402
	0	0.0	0
	2nd Cycle	25	7.5
50		15.0	803
75		22.5	1204
100		30.0	1605
125		37.5	2006
150		45.0	2407
175		52.5	2808
200		60.0	3209
150		45.0	2407
100		30.0	1605
3rd Cycle	50	15.0	803
	0	0.0	0
	50	15.0	803
	100	30.0	1605
	150	45.0	2407
	200	60.0	3209
	225	67.5	3610
	250	75.0	4011
	275	82.5	4412
	300	90.0	4813
250	75.0	4011	
200	60.0	3209	
150	45.0	2407	
100	30.0	1605	
50	15.0	803	
0	0.0	0	

Notes:

*Reading to be taken every 5 minutes.

*For 200% of loading maintained

- 1st hour of reading to be taken every 15 minutes;
- subsequent reading to be taken hourly.

Example (calculation from ton to psi)

For 200T hydraulic jack, cylinder effective area = 41.22in²
1T = 2204lb

For 90Tonne, the pressure in PSI = $(90 \times 2204) / 41.22$
= 4813 psi

APPENDIX C1

Project Codename: TOP/MUAR/CORRELATION
(Test ID: YJMY111-TOP1A; Test Date: 2015.12.21)

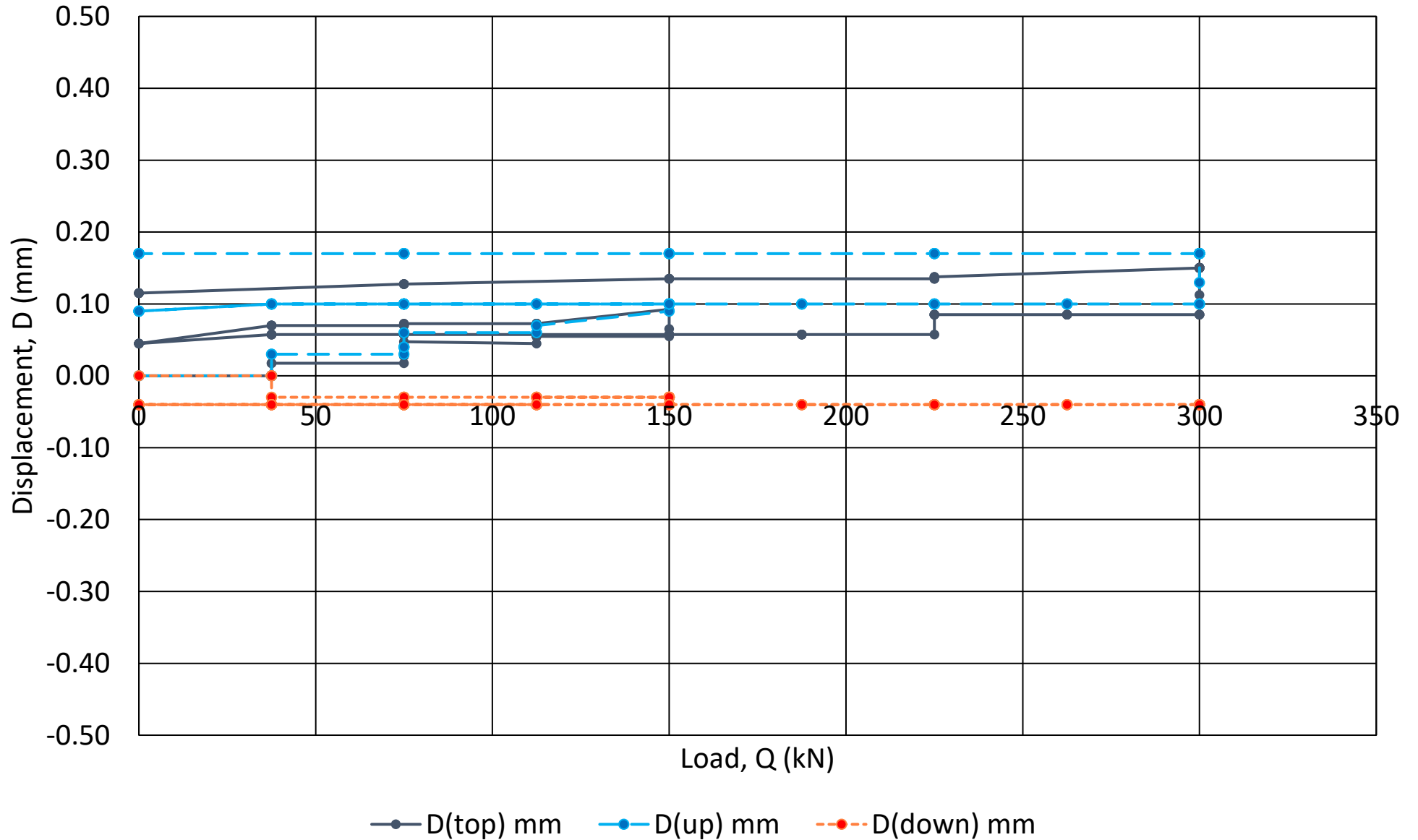

Project Codename: TOP/MUAR/CORRELATION
(Test ID: YJMY111-TOP1A; Test Date: 2015.12.21)

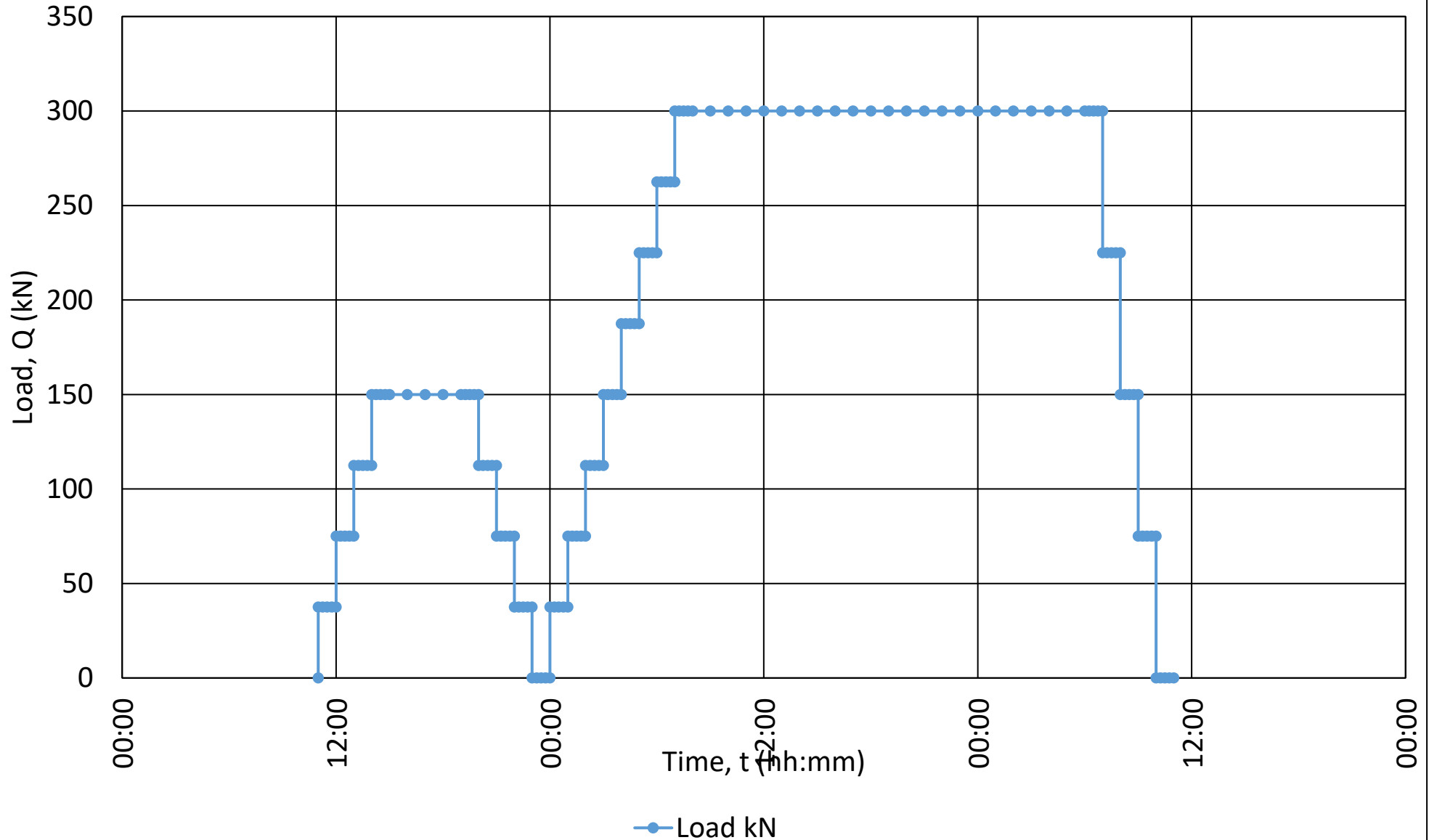

Project Codename: TOP/MUAR/CORRELATION
(Test ID: YJMY111-TOP1A; Test Date: 2015.12.21)

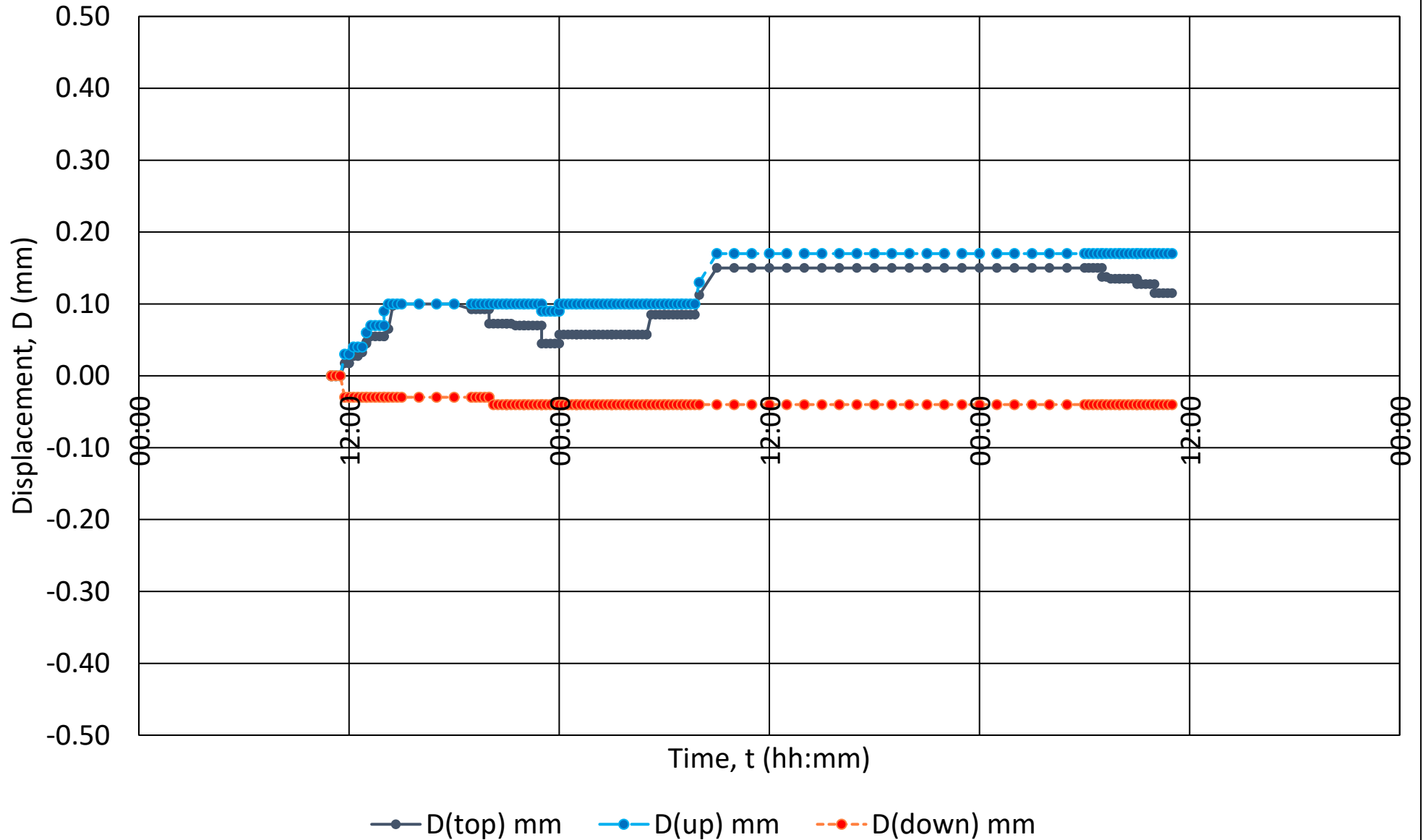

Project Codename: TOP/MUAR/CORRELATION
(Test ID: YJMY111-TOP1A; Test Date: 2015.12.21)

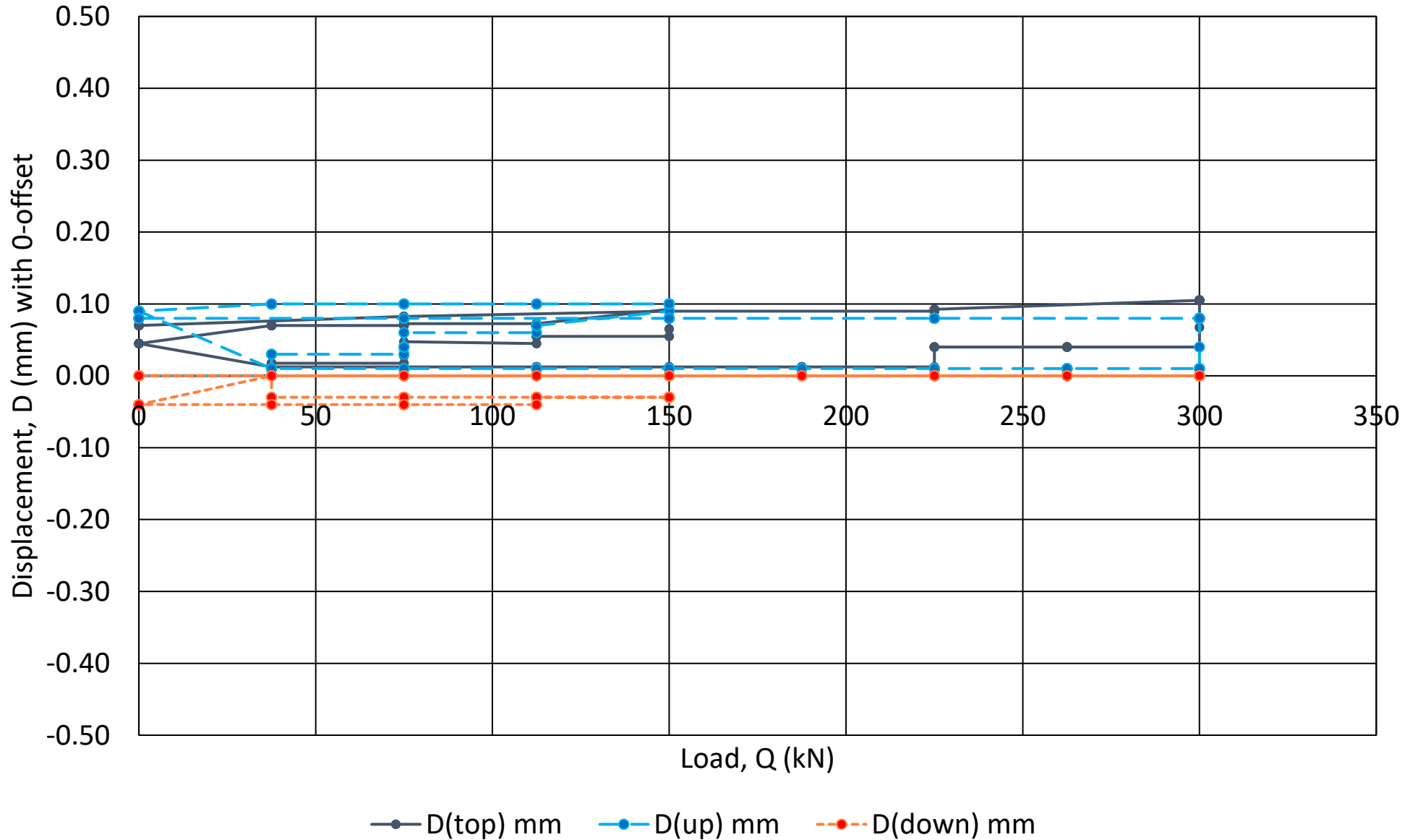

Project Codename: TOP/MUAR/CORRELATION
(Test ID: YJMY111-TOP1A; Test Date: 2015.12.21)

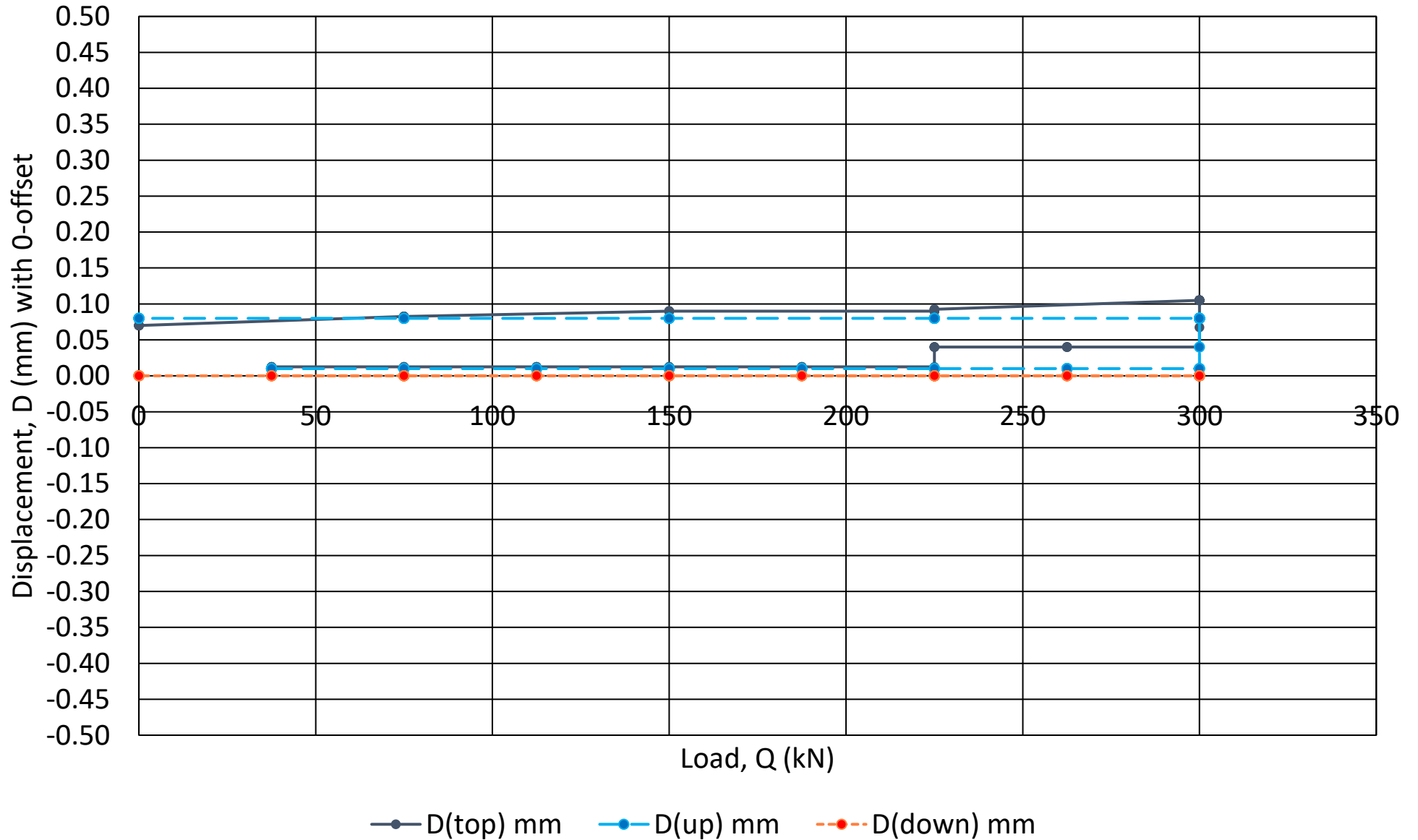

Project Codename: TOP/MUAR/CORRELATION
 (Test ID: YJMY111-TOP1A; Test Date: 2015.12.21)

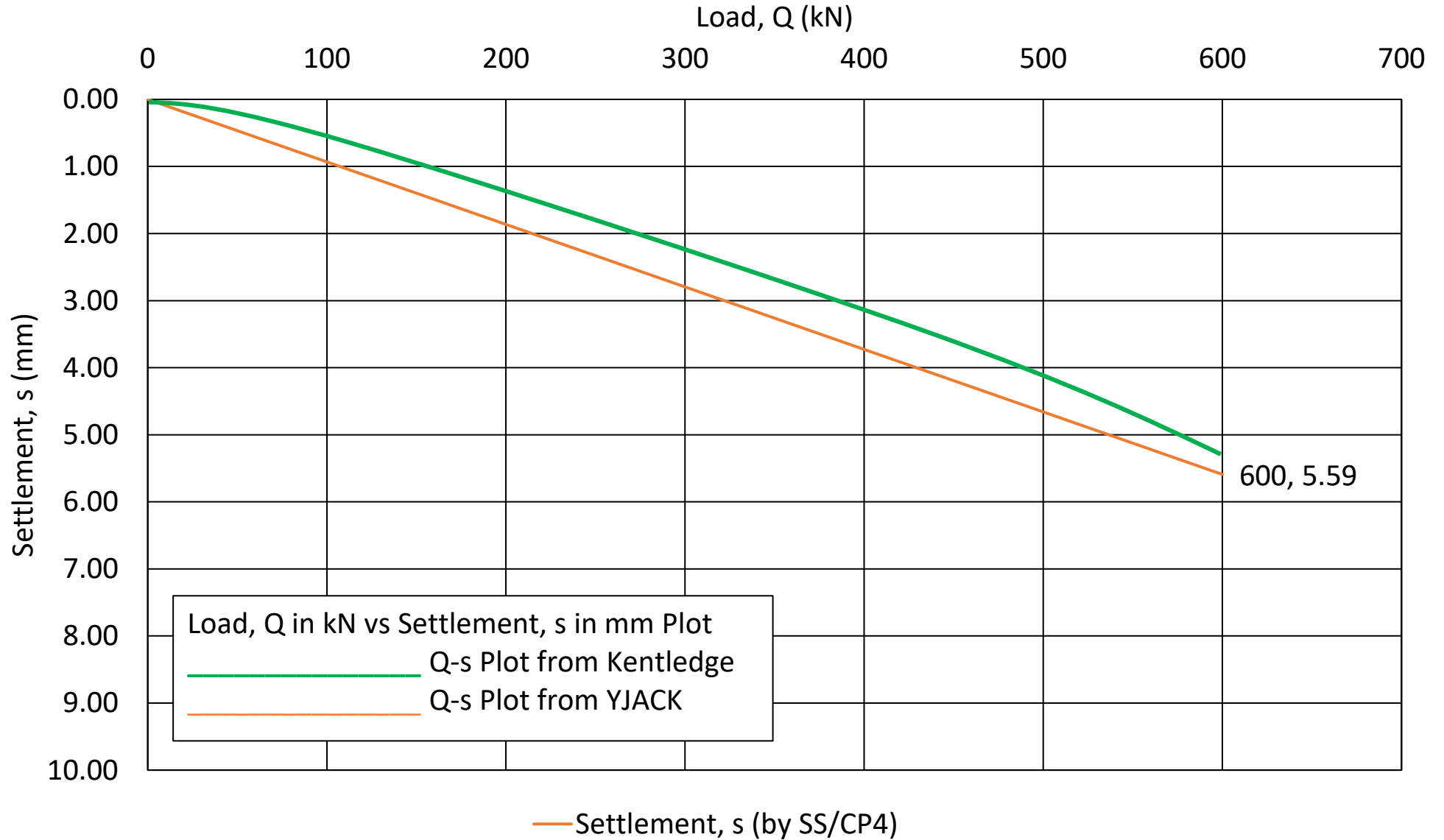

Project Codename: TOP/MUAR/CORRELATION
(Test ID: YJMY111-TOP1B; Test Date: 2015.12.23)

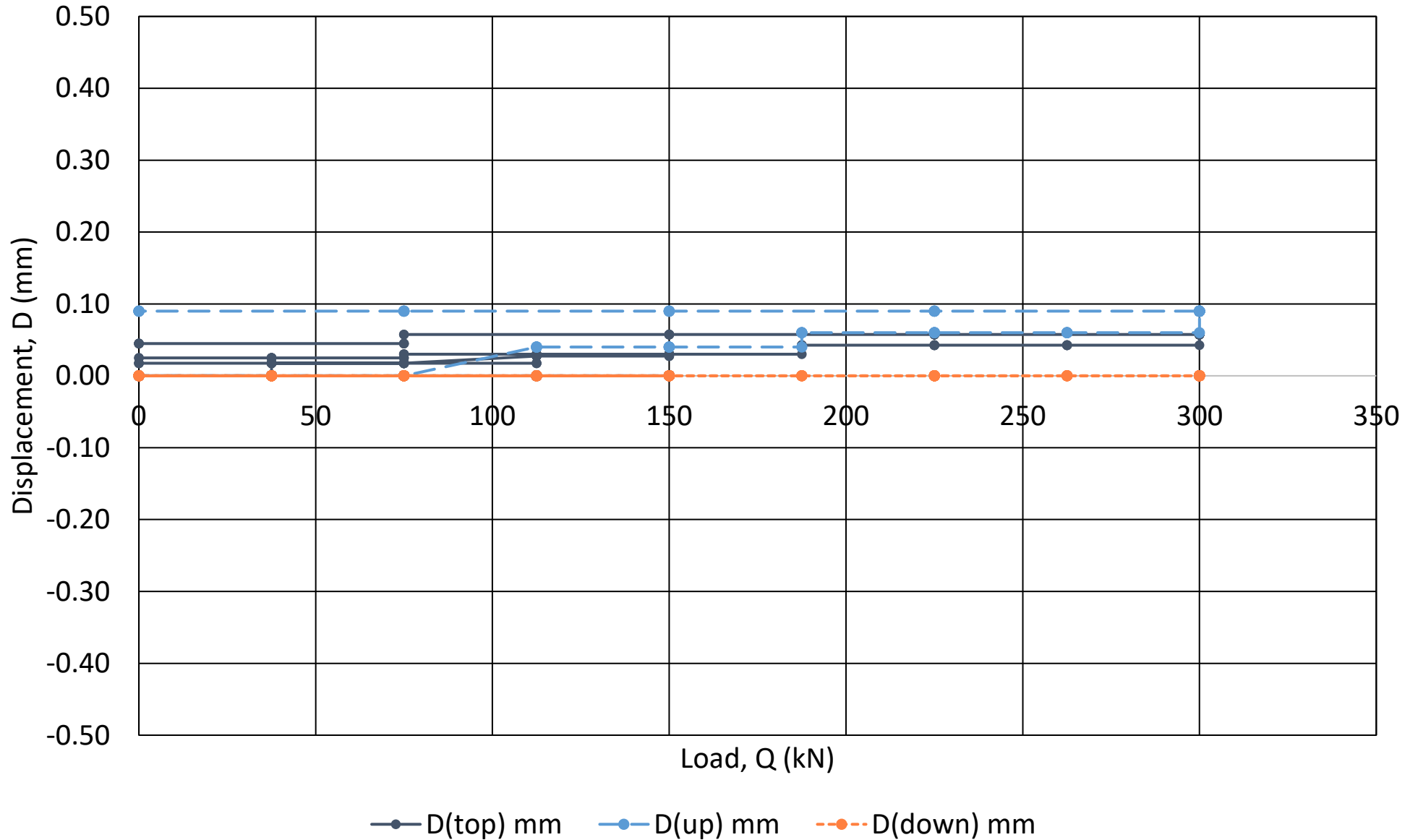

Project Codename: TOP/MUAR/CORRELATION
(Test ID: YJMY111-TOP1B; Test Date: 2015.12.23)

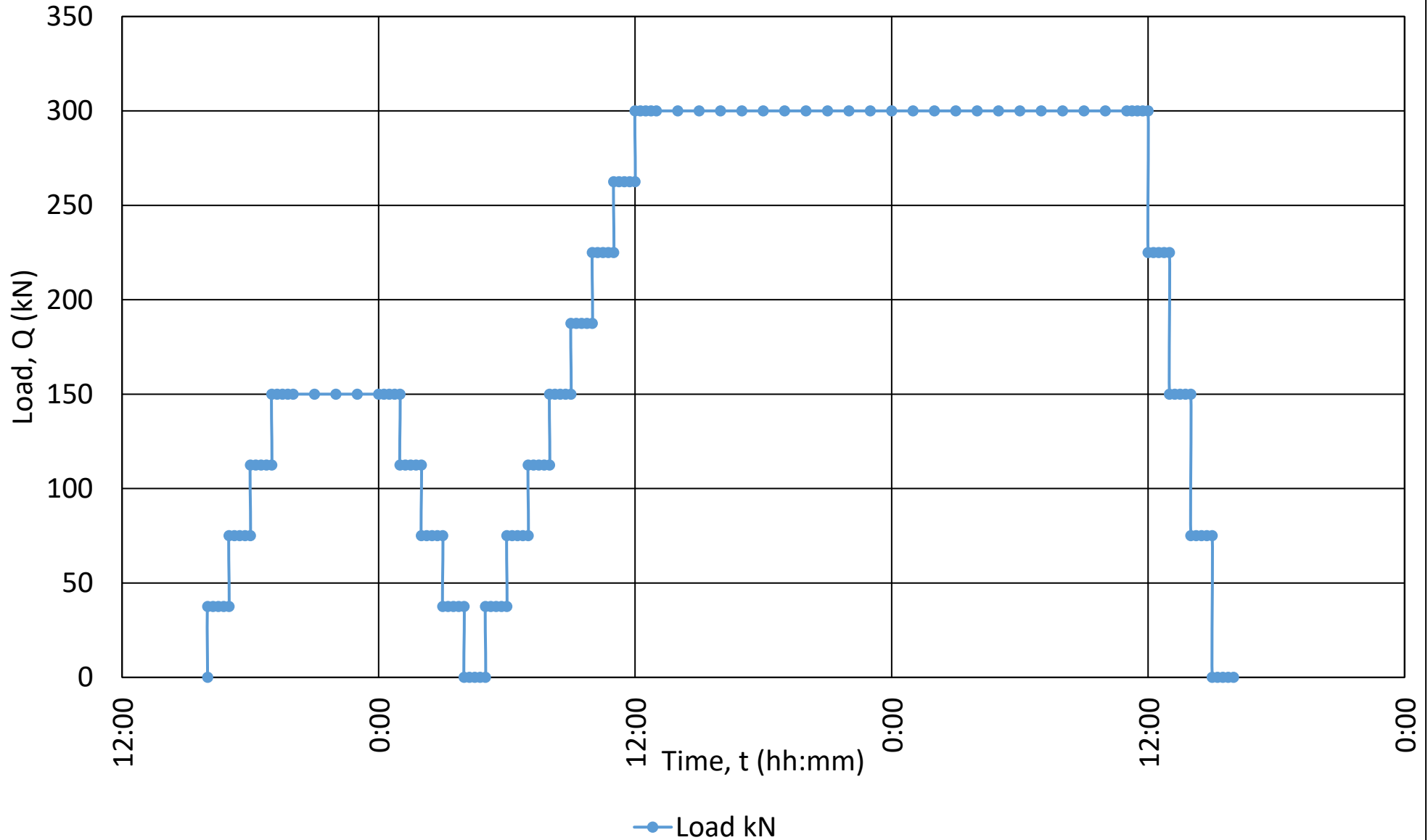

Project Codename: TOP/MUAR/CORRELATION
(Test ID: YJMY111-TOP1B; Test Date: 2015.12.23)

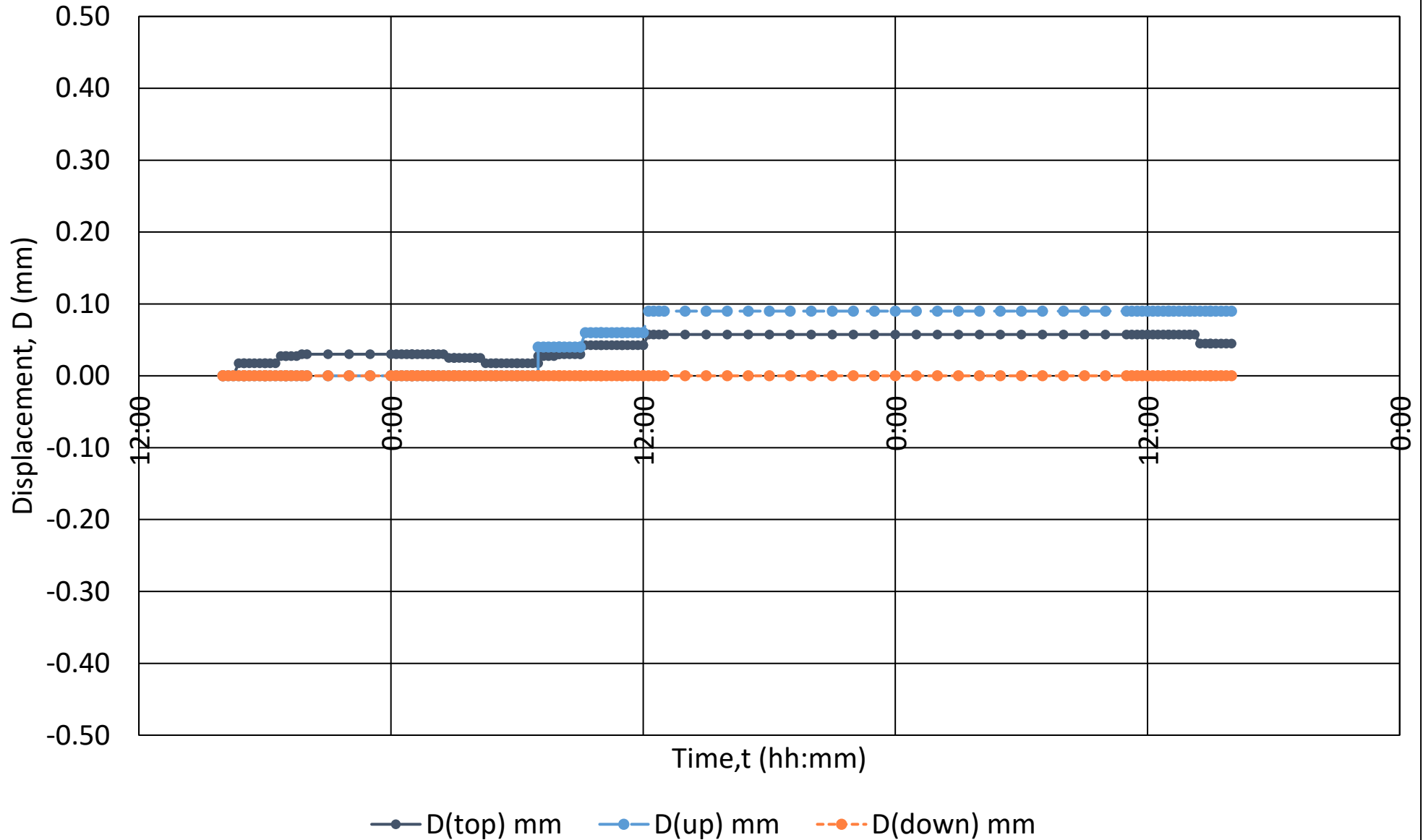

Project Codename: TOP/MUAR/CORRELATION
(Test ID: YJMY111-TOP1B; Test Date: 2015.12.23)

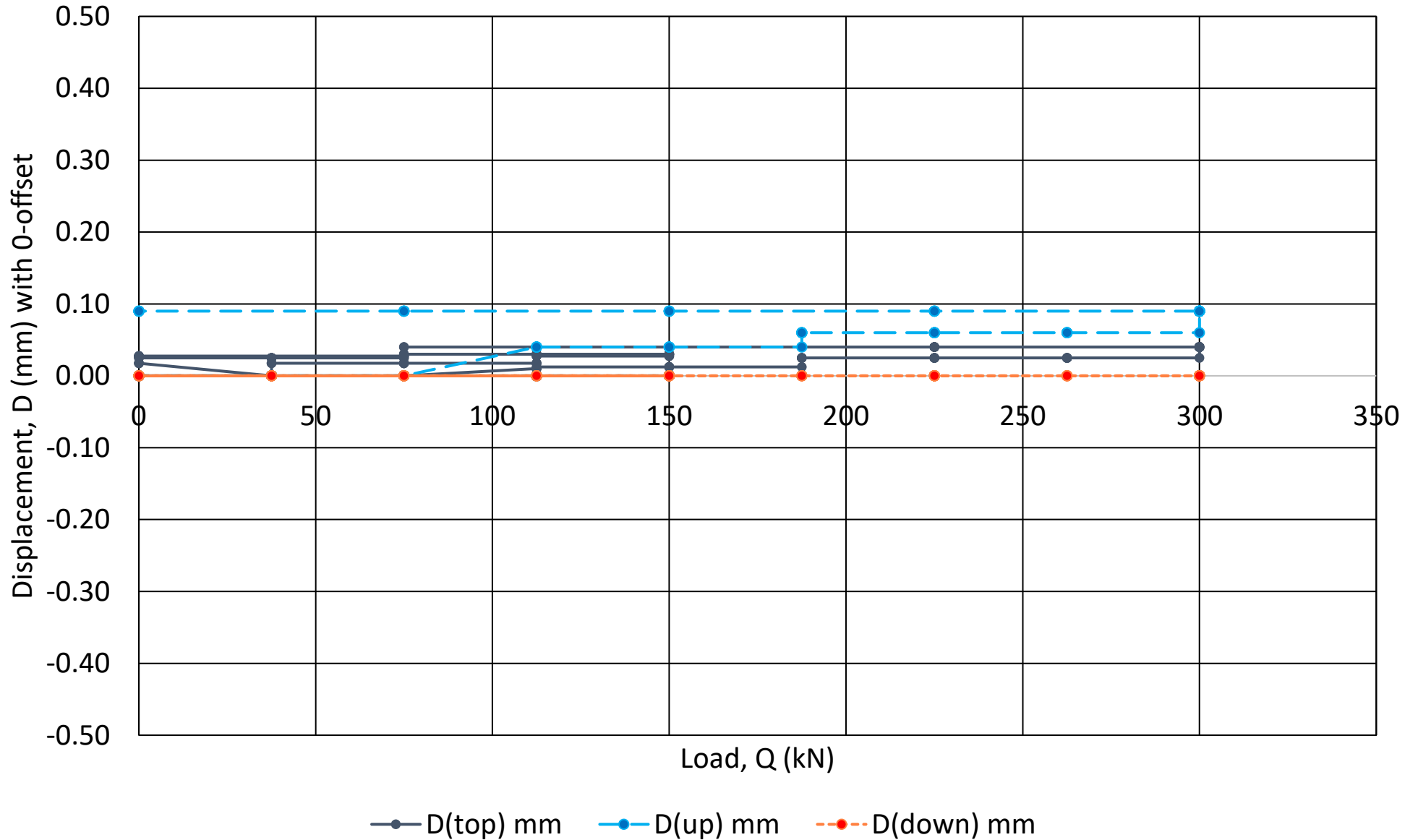

Project Codename: TOP/MUAR/CORRELATION
(Test ID: YJMY111-TOP1B; Test Date: 2015.12.23)

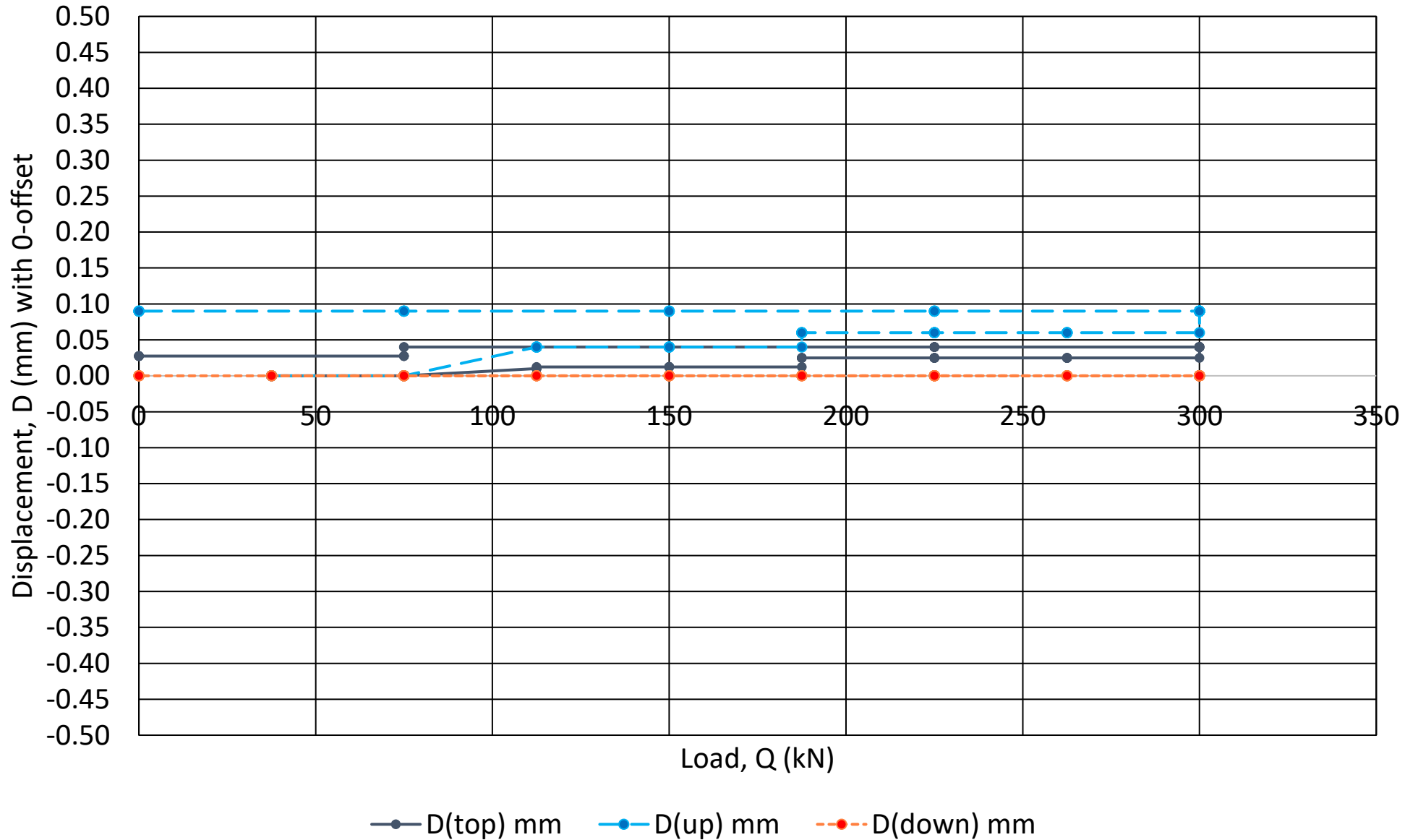

Project Codename: TOP/MUAR/CORRELATION
(Test ID: YJMY111-TOP1B; Test Date: 2015.12.23)

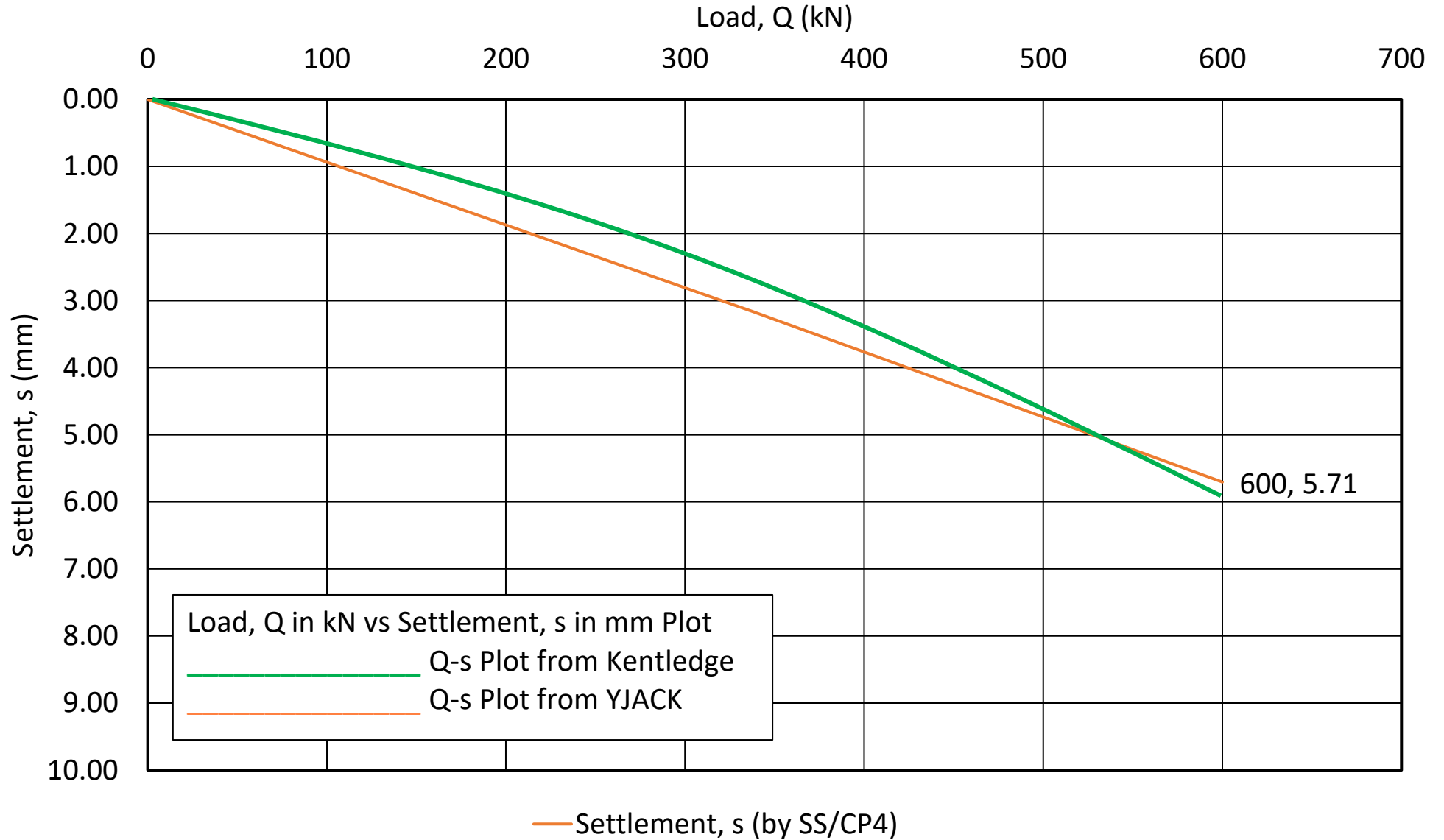

Project Codename: TOP/MUAR/CORRELATION
(Test ID: YJMY111-TOP2A; Test Date: 2015.12.26)

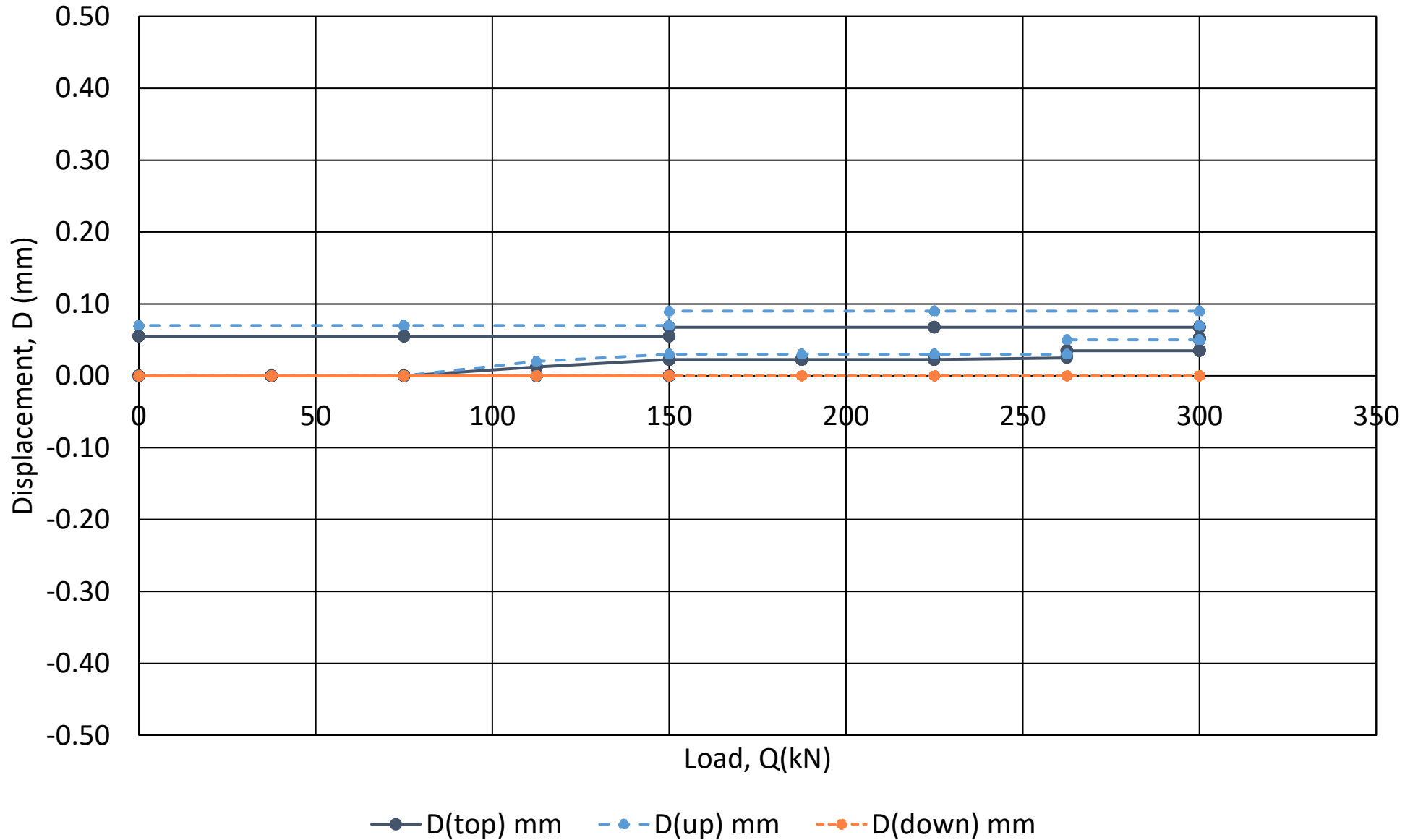

Project Codename: TOP/MUAR/CORRELATION
(Test ID: YJMY111-TOP2A; Test Date: 2015.12.26)

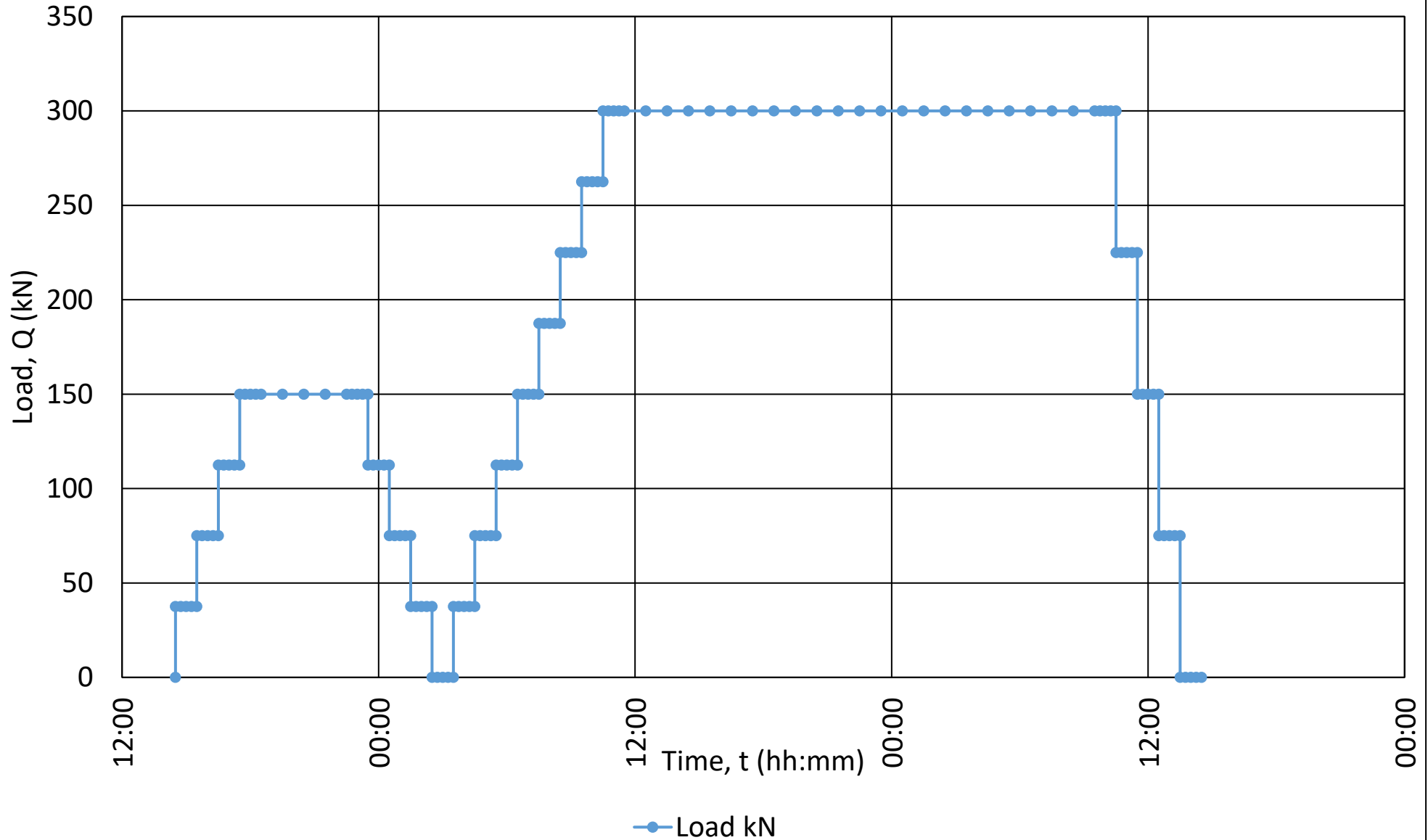

Project Codename: TOP/MUAR/CORRELATION
(Test ID: YJMY111-TOP2A; Test Date: 2015.12.26)

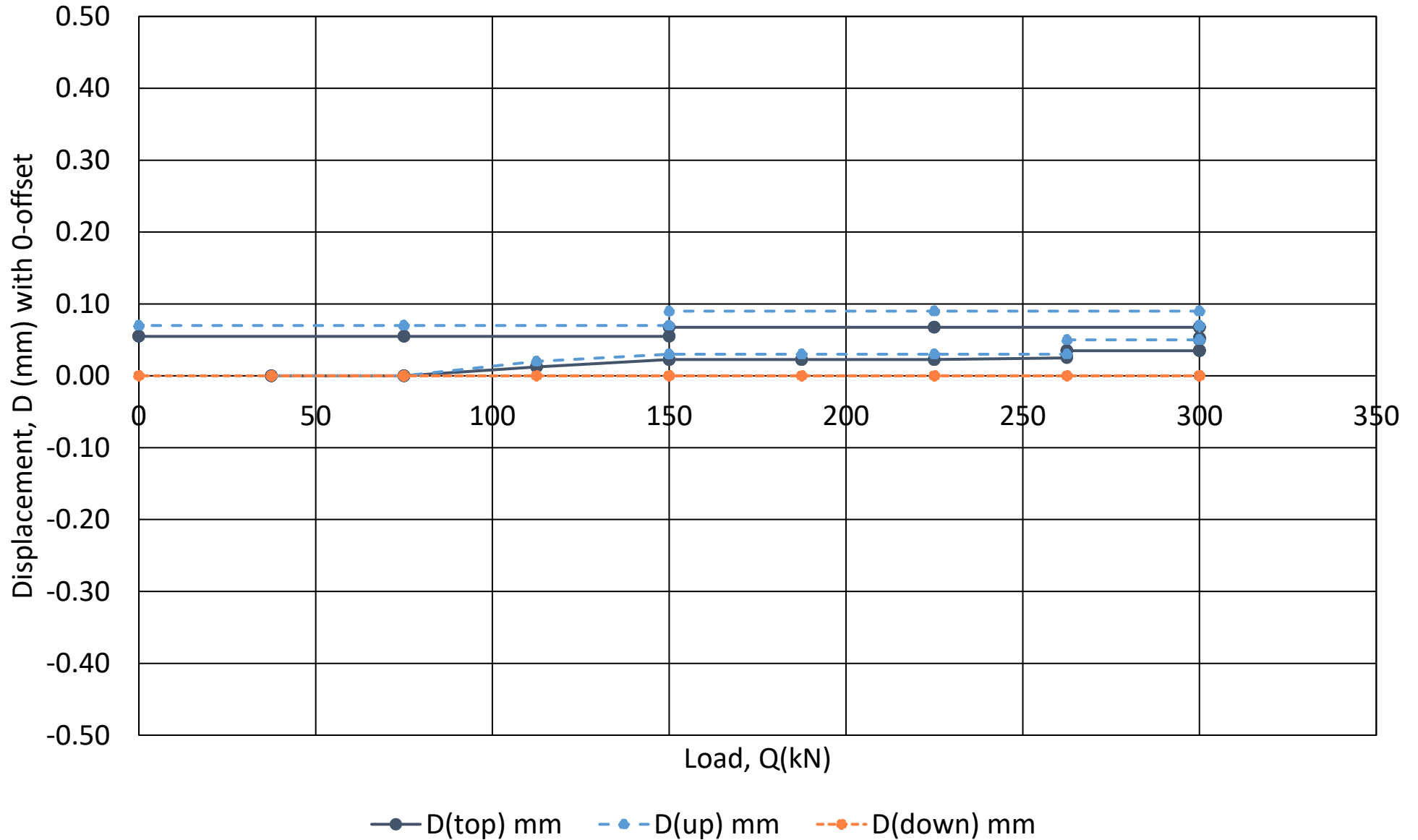

Project Codename: TOP/MUAR/CORRELATION
(Test ID: YJMY111-TOP2A; Test Date: 2015.12.26)

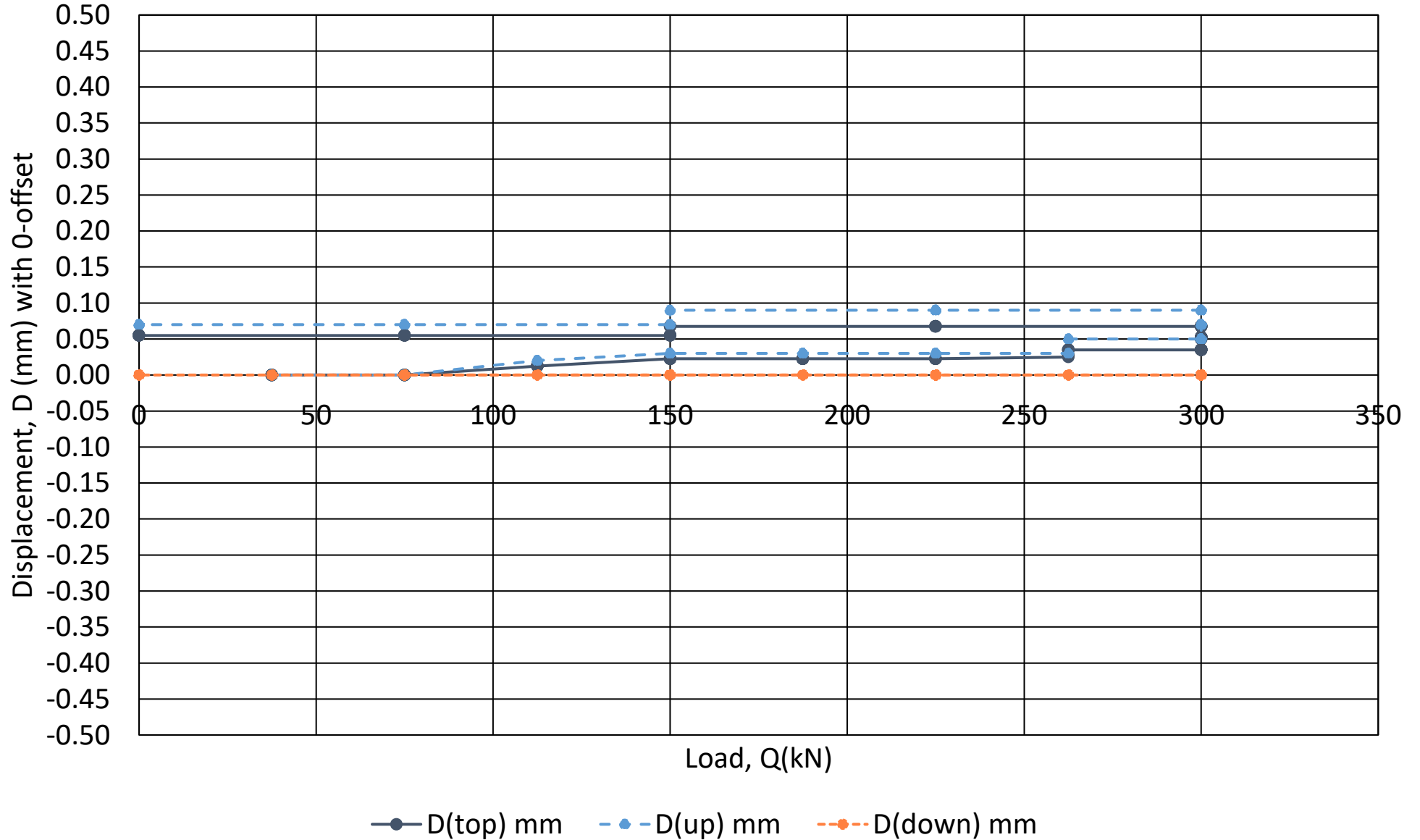

Project Codename: TOP/MUAR/CORRELATION
(Test ID: YJMY111-TOP2A; Test Date: 2015.12.26)

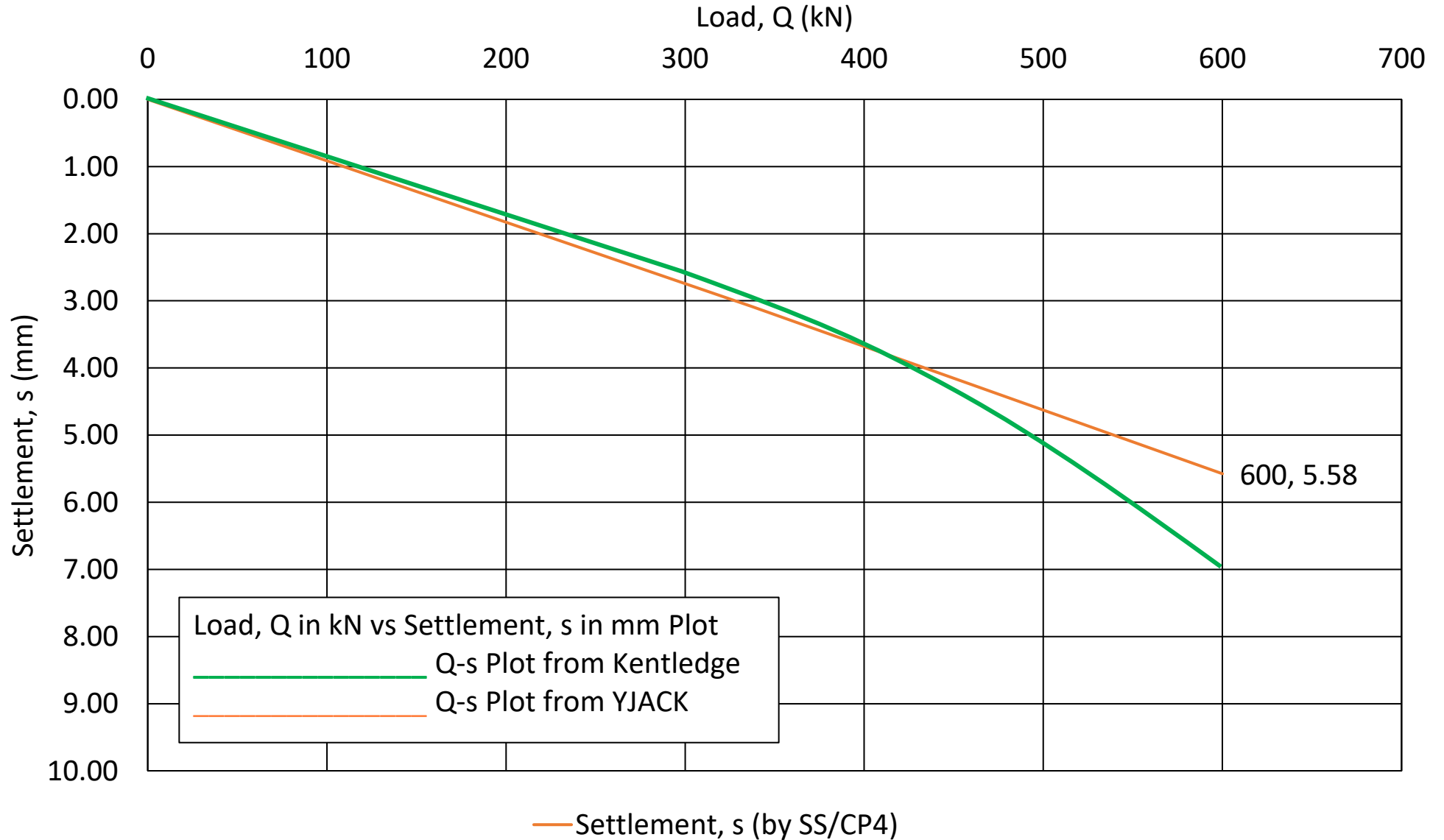

Project Codename: TOP/MUAR/CORRELATION
(Test ID: YJMY111-TOP2B; Test Date: 2015.12.28)

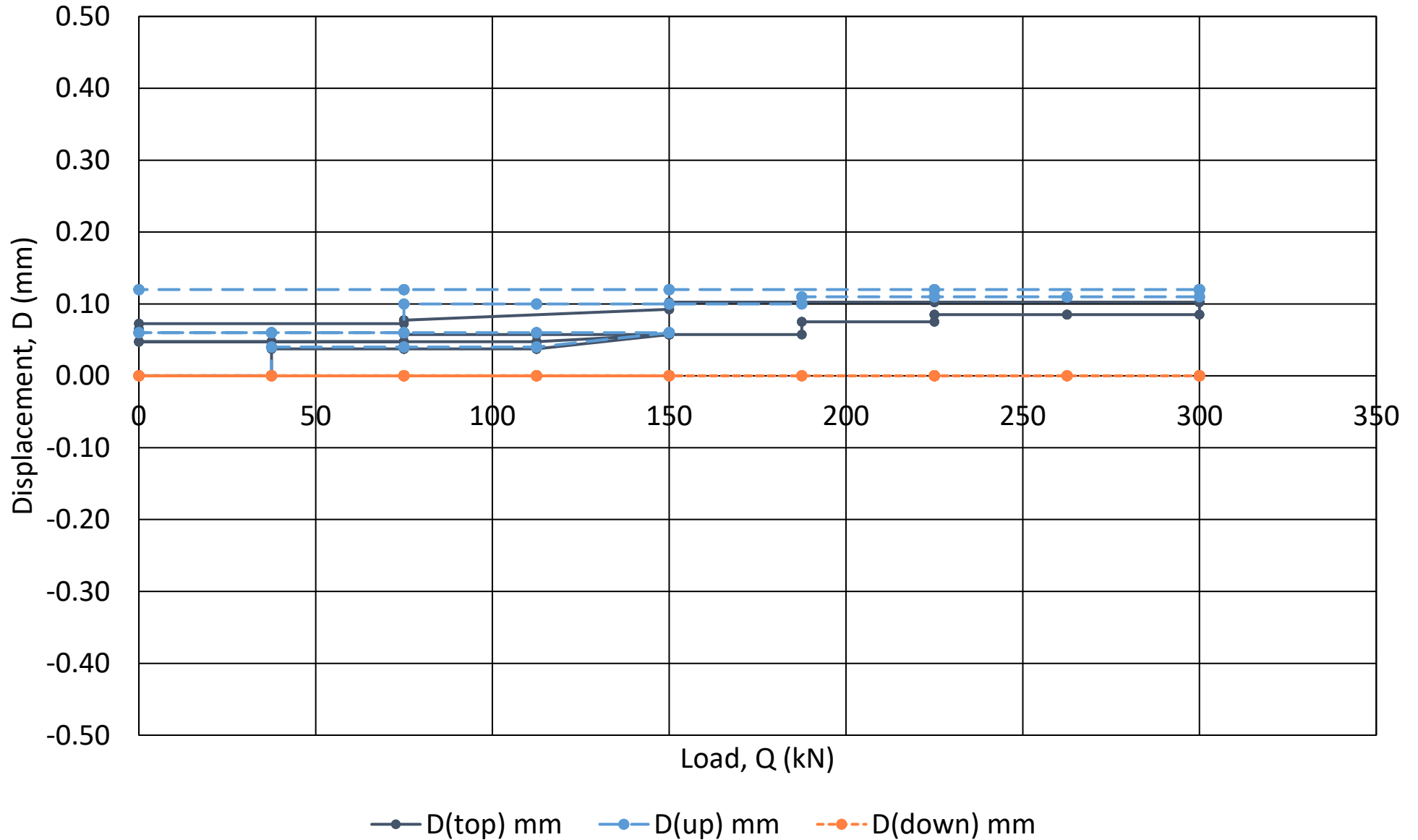

Project Codename: TOP/MUAR/CORRELATION
(Test ID: YJMY111-TOP2B; Test Date: 2015.12.28)

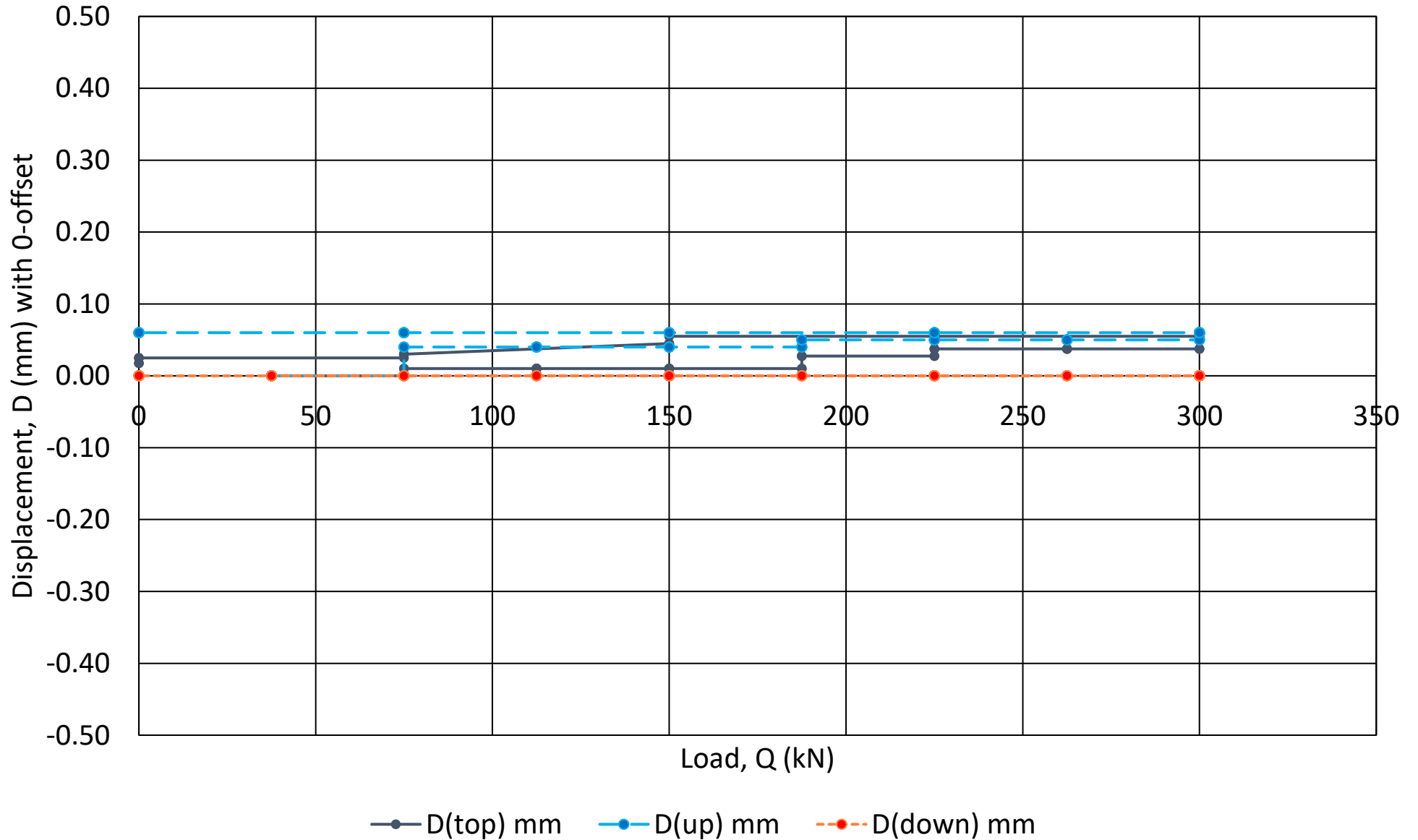

Project Codename: TOP/MUAR/CORRELATION
(Test ID: YJMY111-TOP2B; Test Date: 2015.12.28)

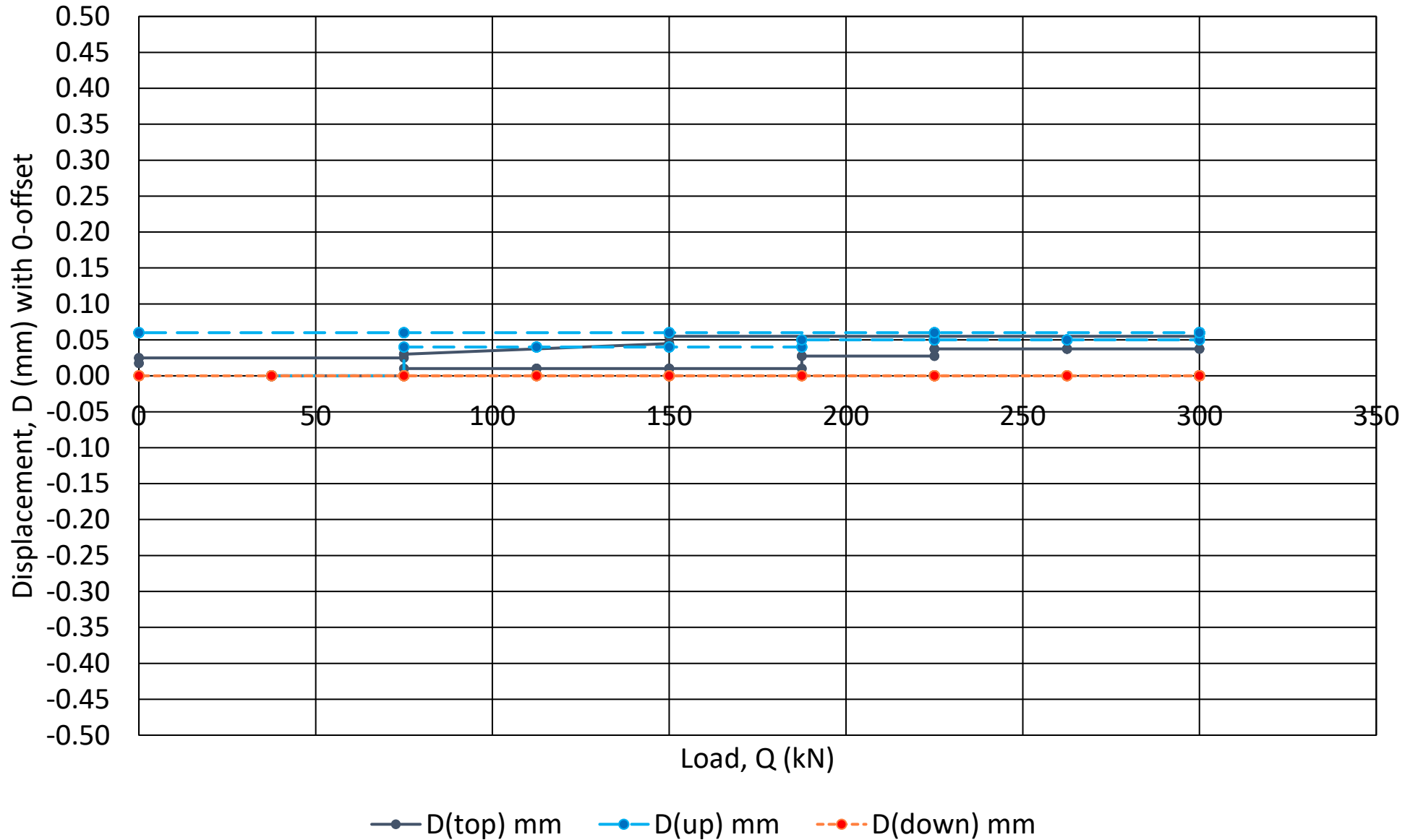

Project Codename: TOP/MUAR/CORRELATION
 (Test ID: YJMY111-TOP2B; Test Date: 2015.12.28)

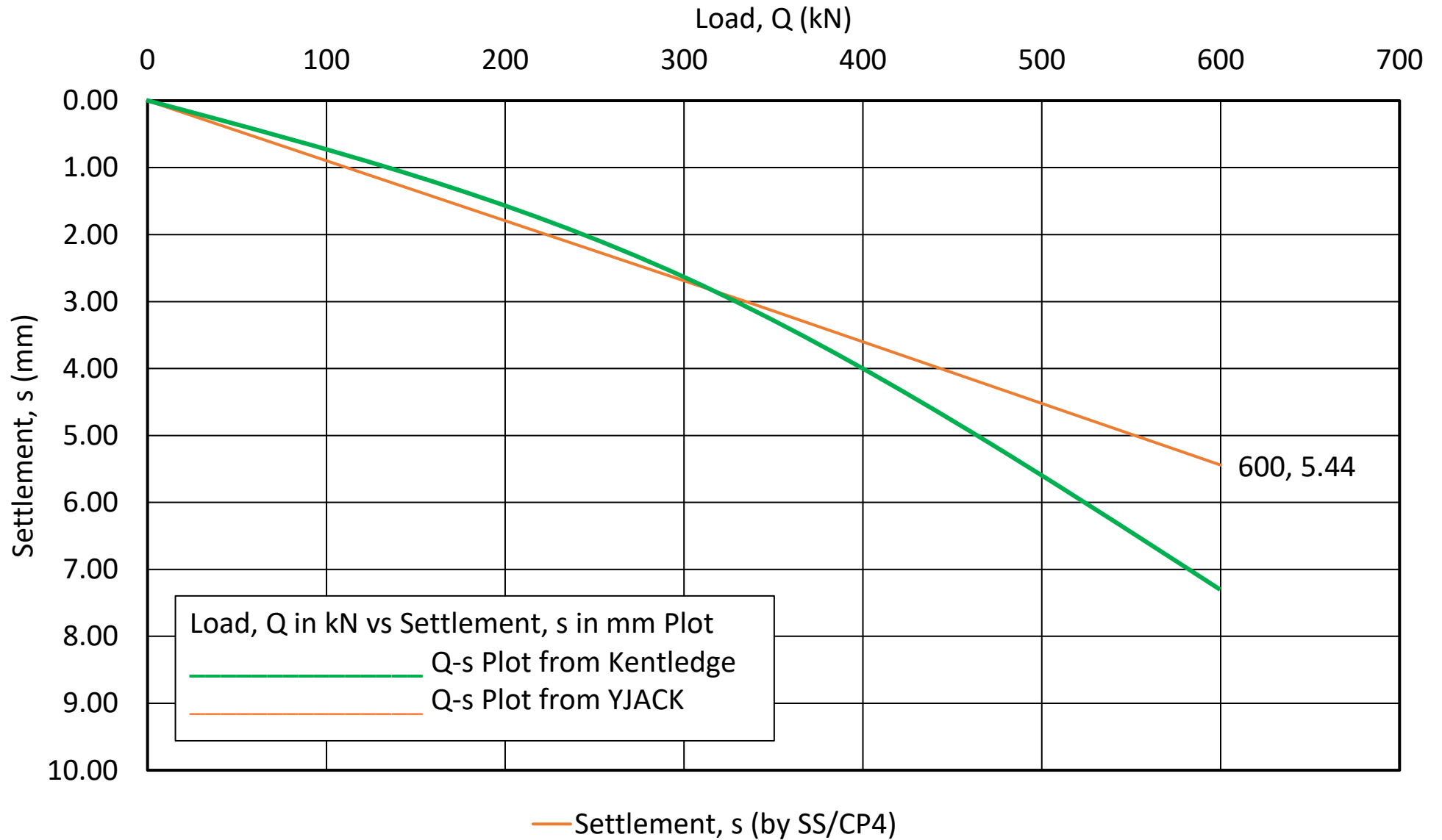

APPENDIX C2

Project Codename: TOP/MUAR/CORRELATION
(Test ID: YJMY111-TOP1A; Test Date: 2015.12.31)

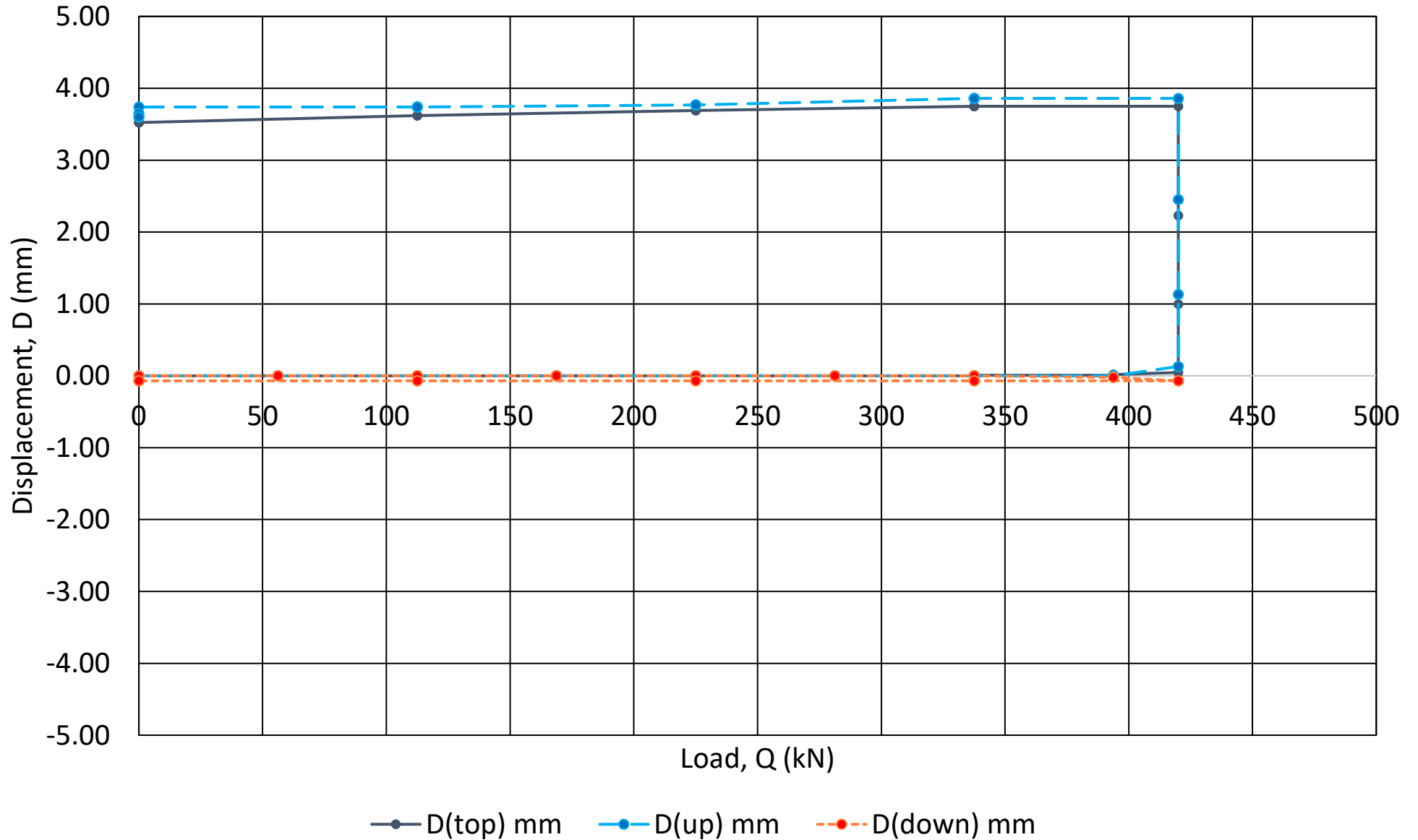

Project Codename: TOP/MUAR/CORRELATION
(Test ID: YJMY111-TOP1A; Test Date: 2015.12.31)

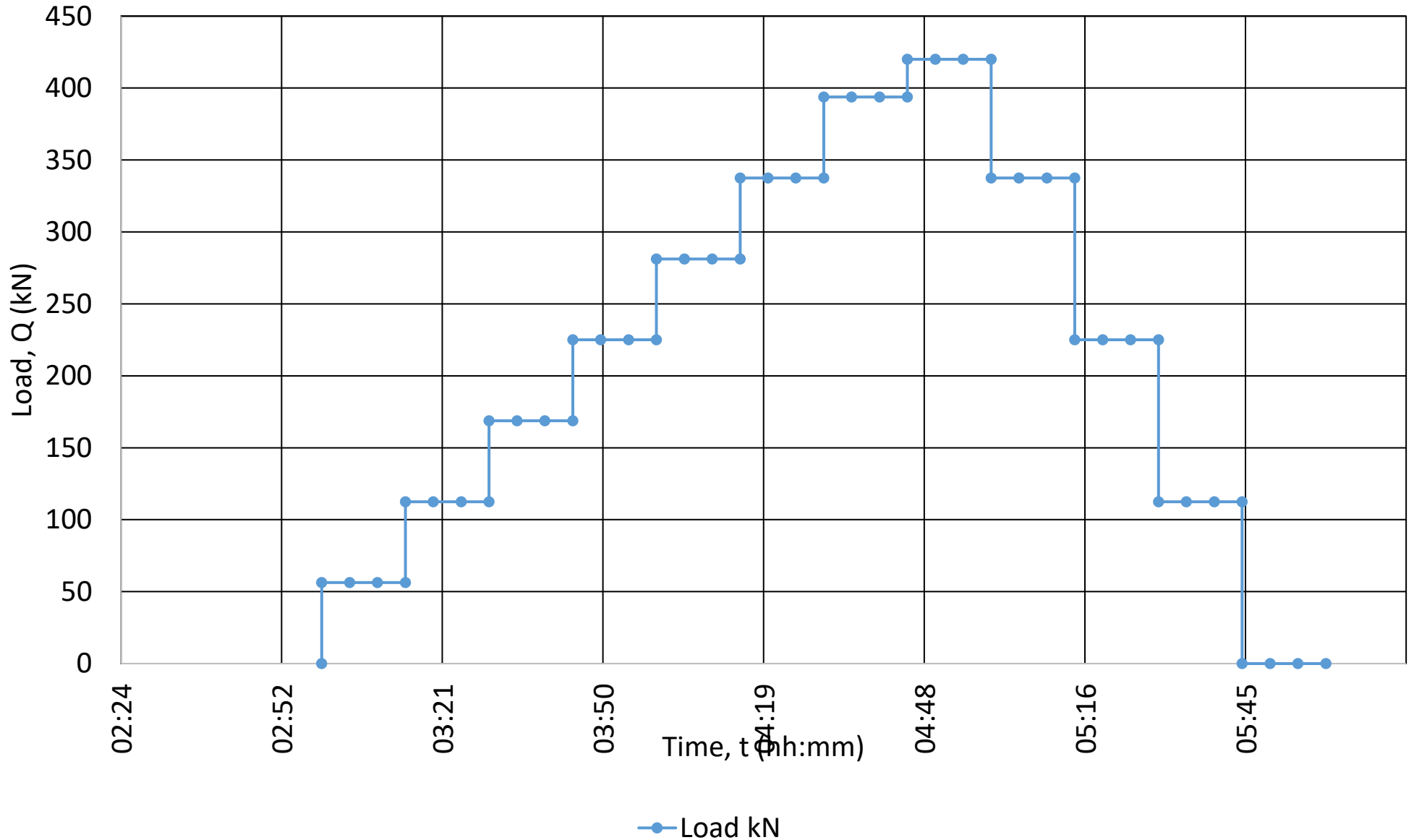

Project Codename: TOP/MUAR/CORRELATION
(Test ID: YJMY111-TOP1A; Test Date: 2015.12.31)

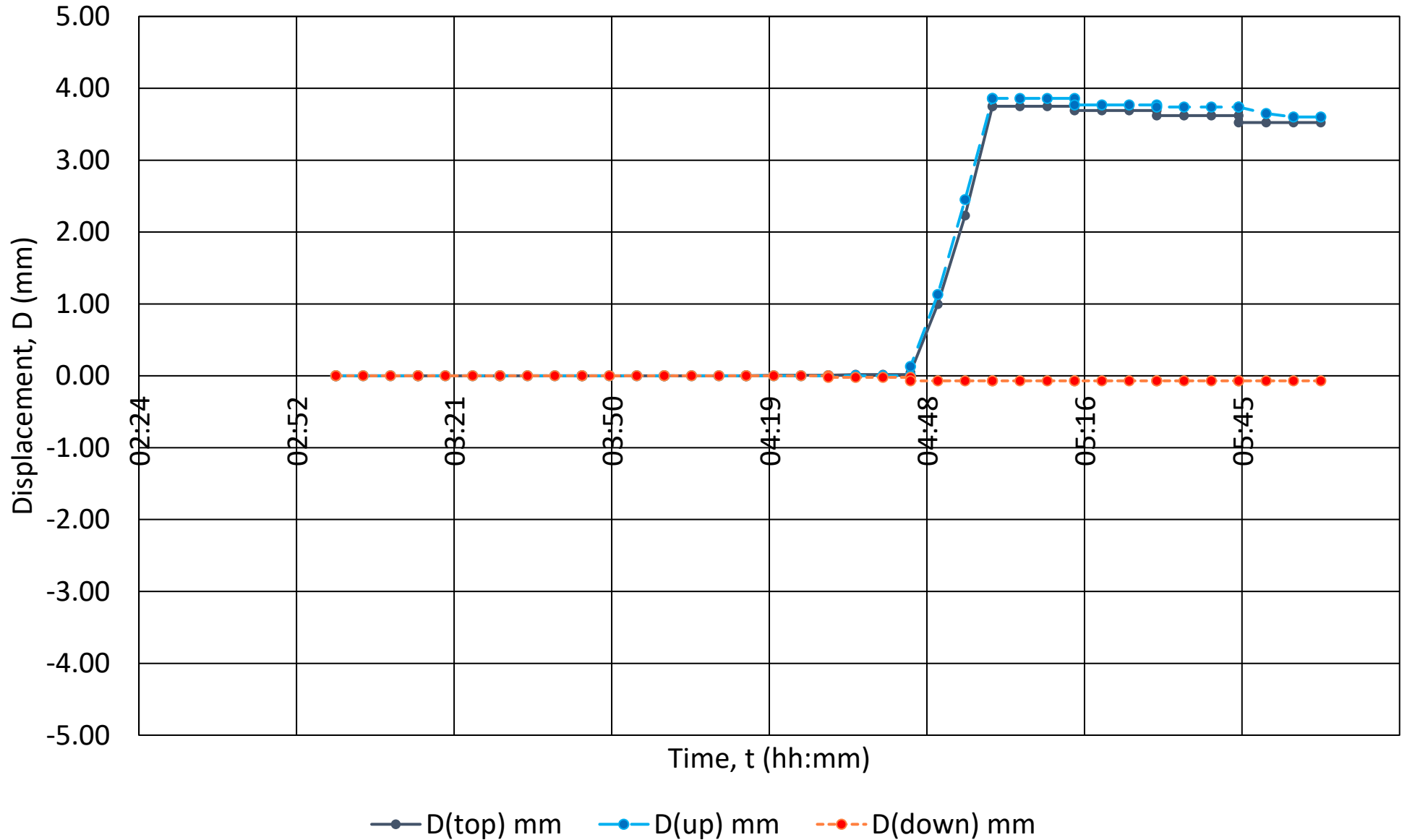

Project Codename: TOP/MUAR/CORRELATION
(Test ID: YJMY111-TOP1A; Test Date: 2015.12.31)

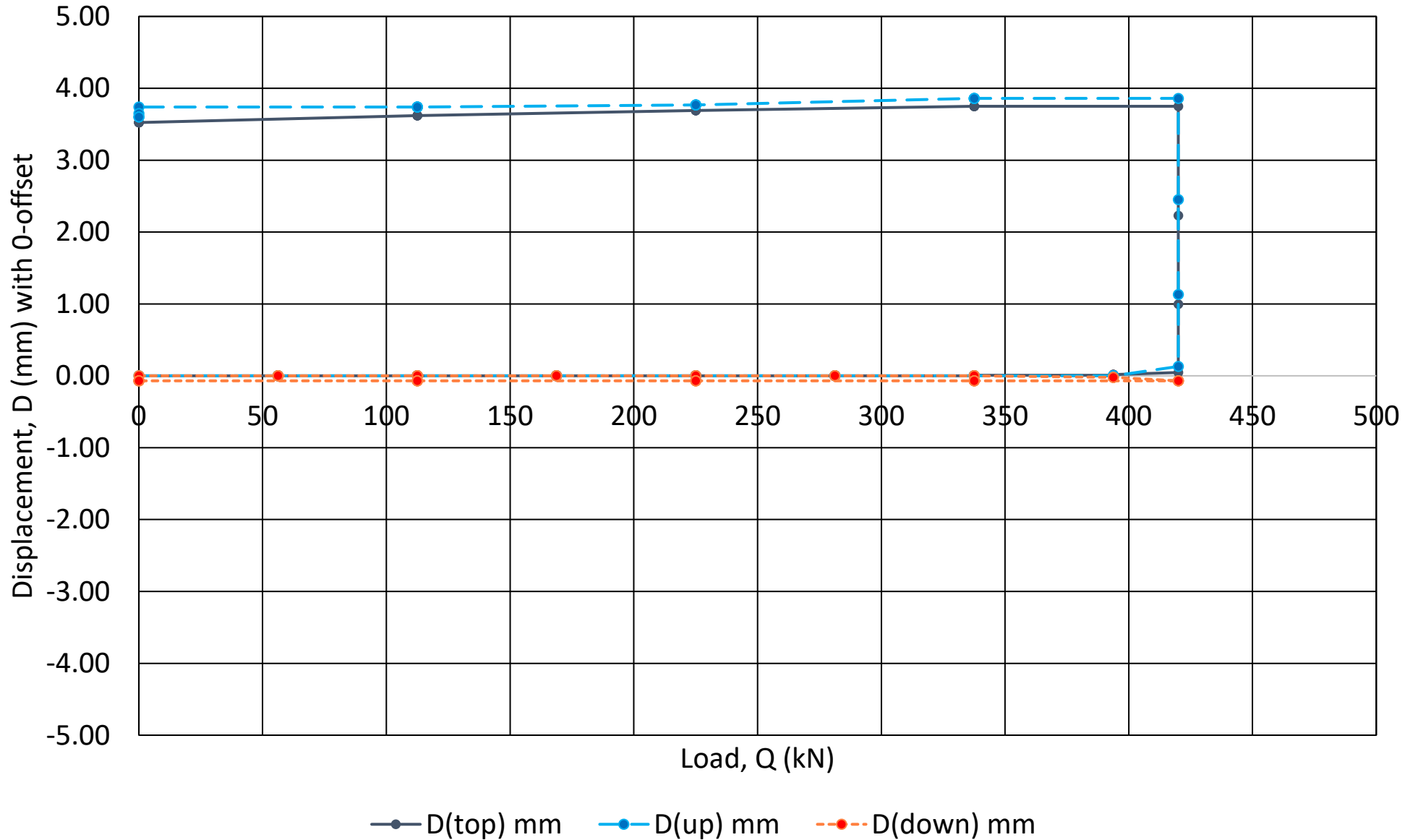

Project Codename: TOP/MUAR/CORRELATION
(Test ID: YJMY111-TOP1A; Test Date: 2015.12.31)

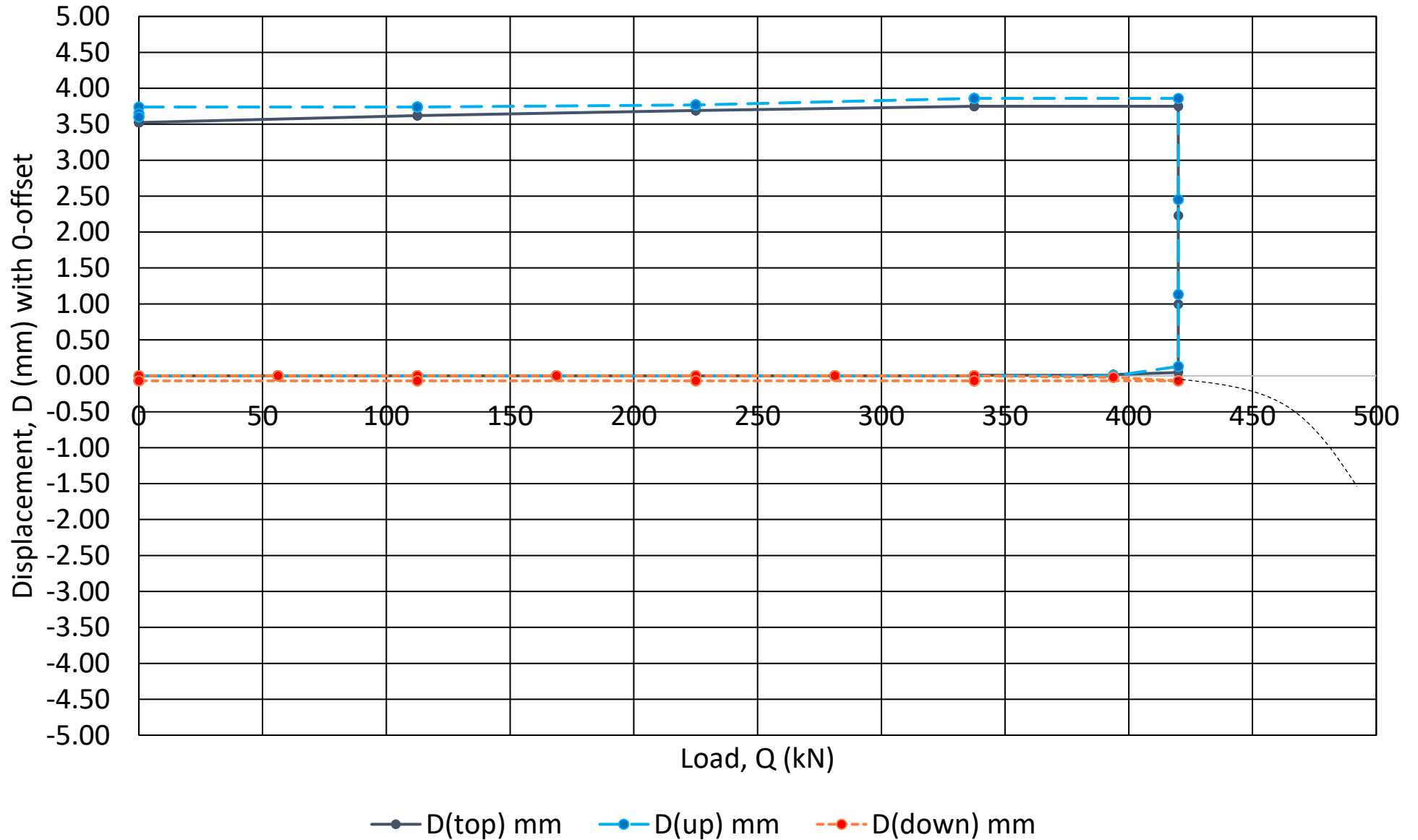

Project Codename: TOP/MUAR/CORRELATION
 (Test ID: YJMY111-TOP1A; Test Date: 2015.12.31)

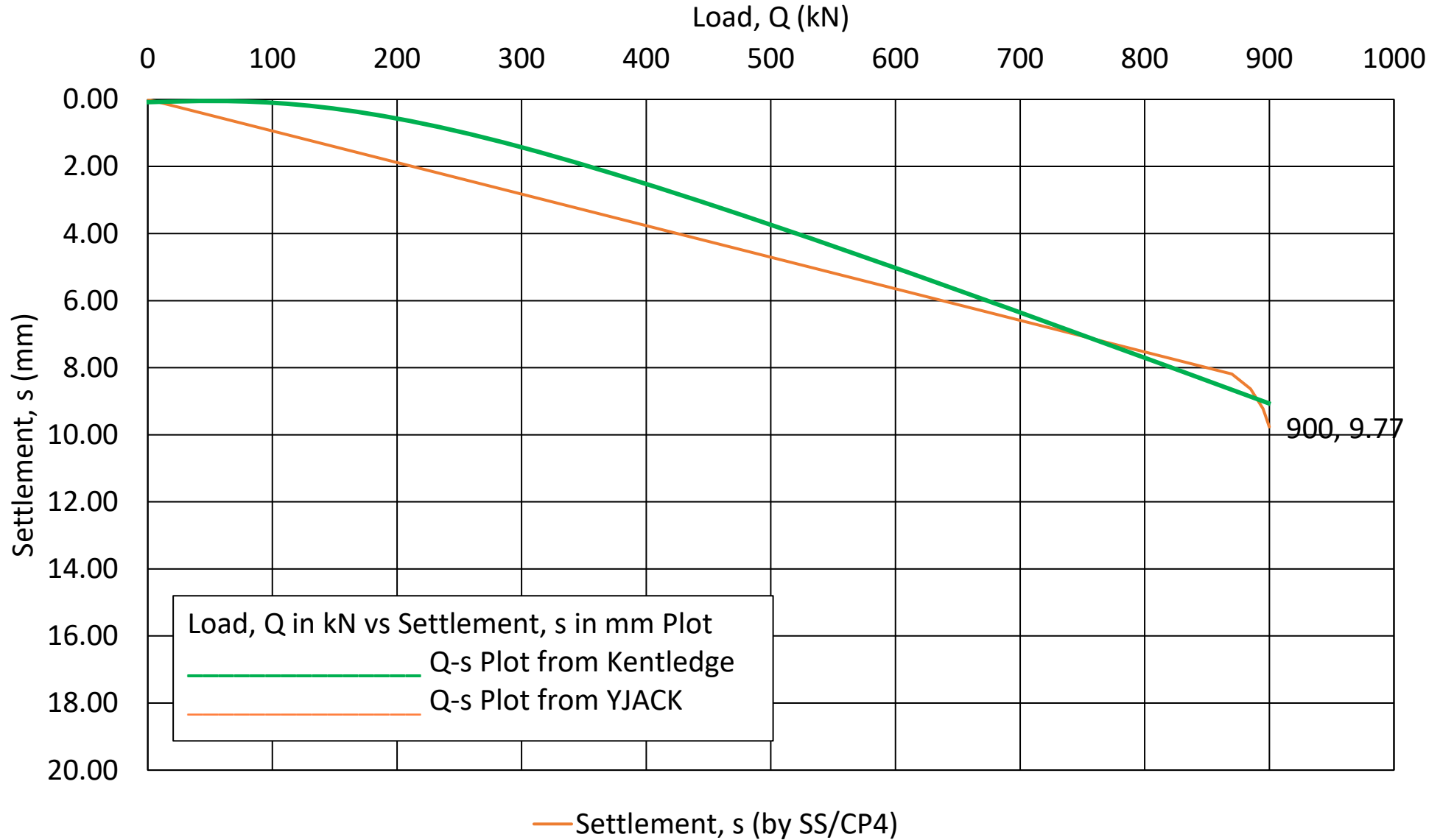

Project Codename: TOP/MUAR/CORRELATION
(Test ID: YJMY111-TOP1B; Test Date: 2015.12.28)

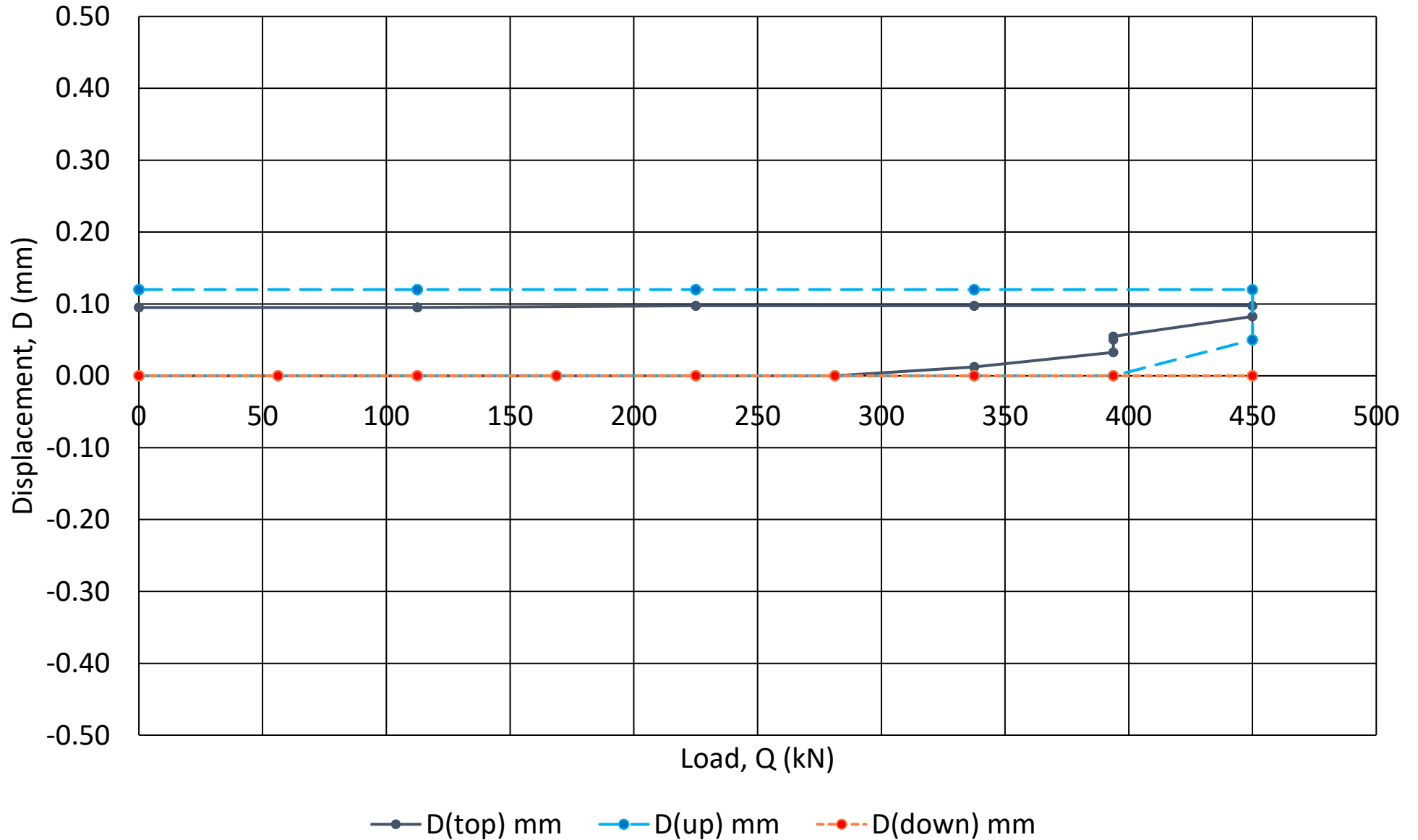

Project Codename: TOP/MUAR/CORRELATION
(Test ID: YJMY111-TOP1B; Test Date: 2015.12.28)

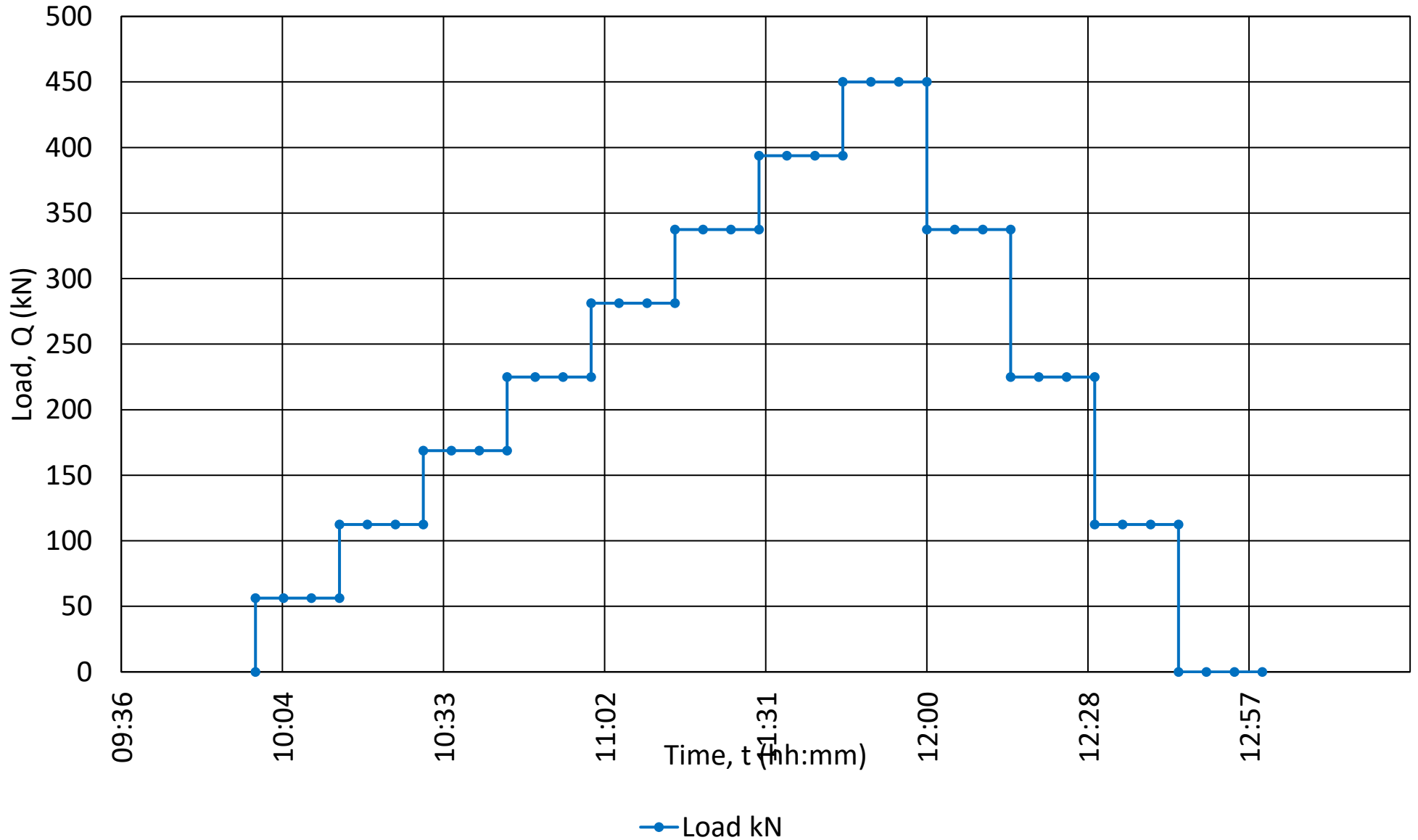

Project Codename: TOP/MUAR/CORRELATION
(Test ID: YJMY111-TOP1B; Test Date: 2015.12.28)

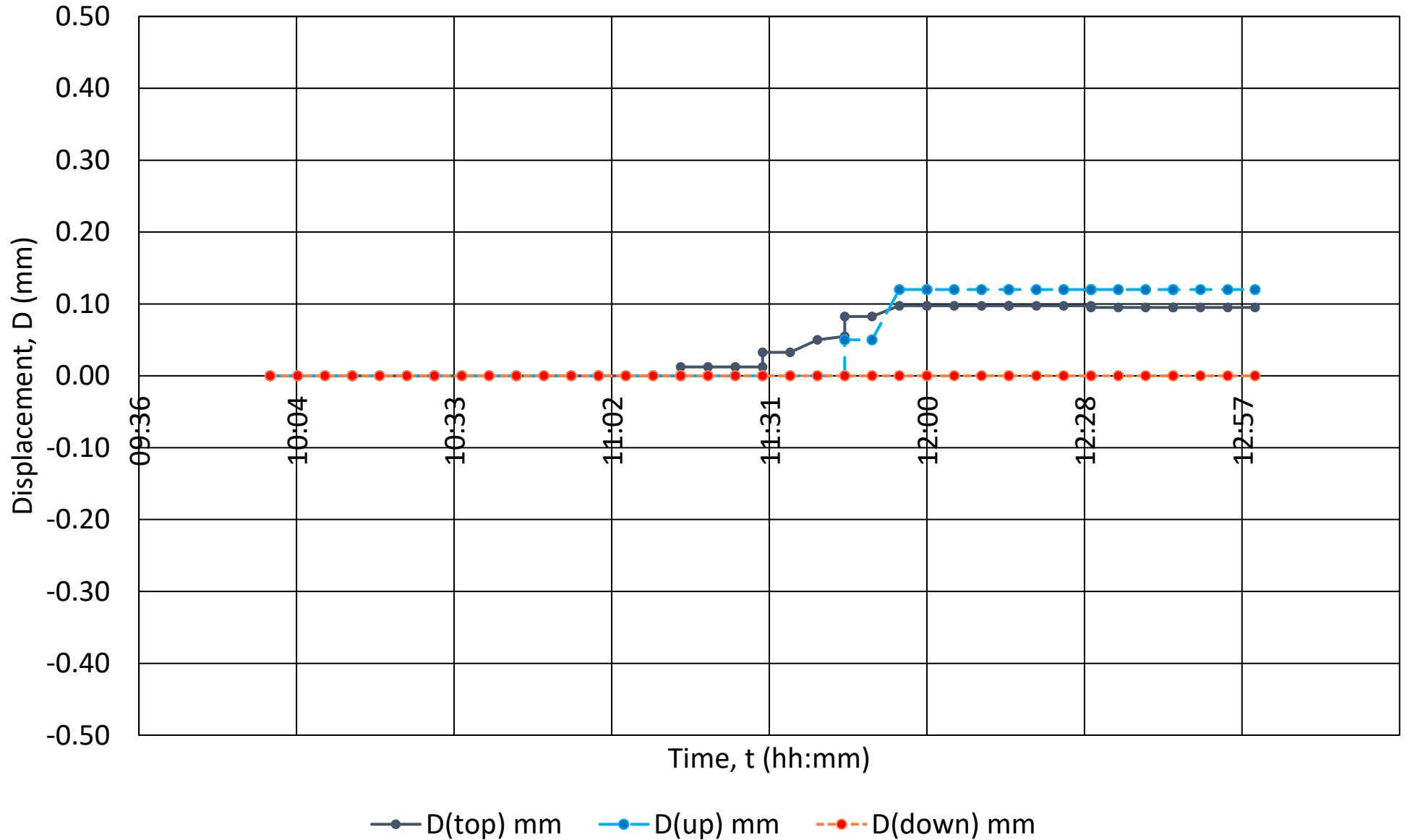

Project Codename: TOP/MUAR/CORRELATION
(Test ID: YJMY111-TOP1B; Test Date: 2015.12.28)

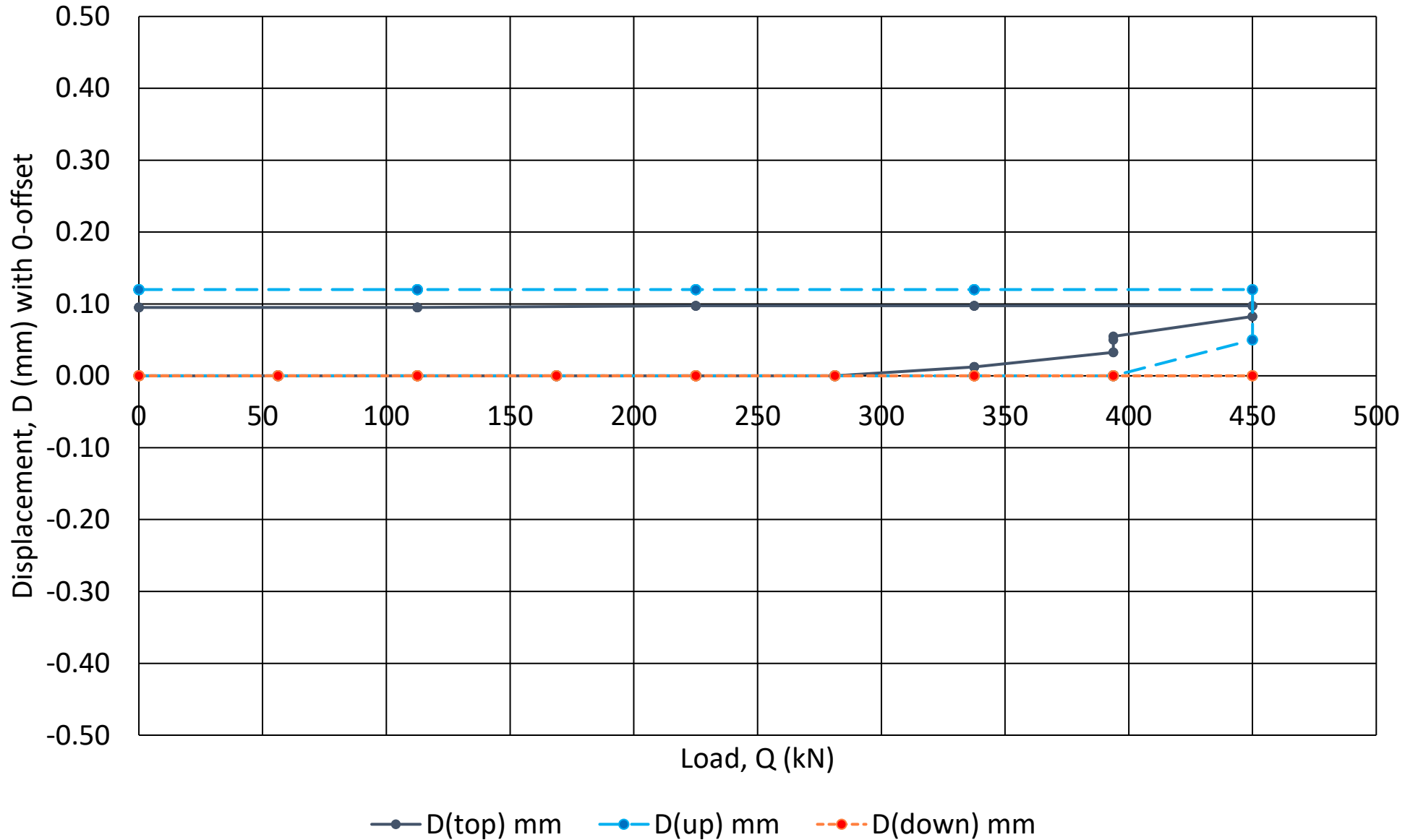

Project Codename: TOP/MUAR/CORRELATION
(Test ID: YJMY111-TOP1B; Test Date: 2015.12.28)

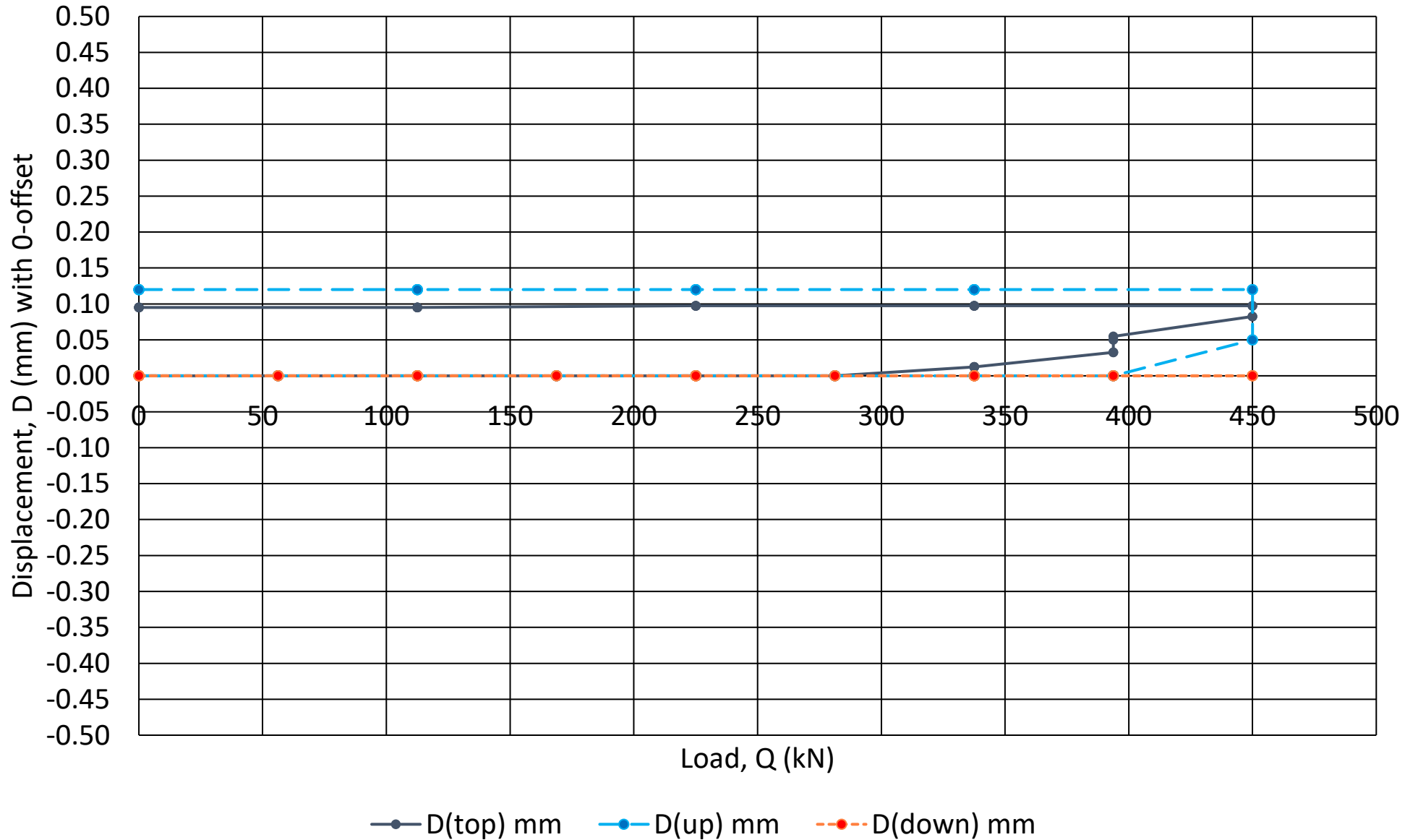

Project Codename: TOP/MUAR/CORRELATION
(Test ID: YJMY111-TOP1B; Test Date: 2015.12.28)

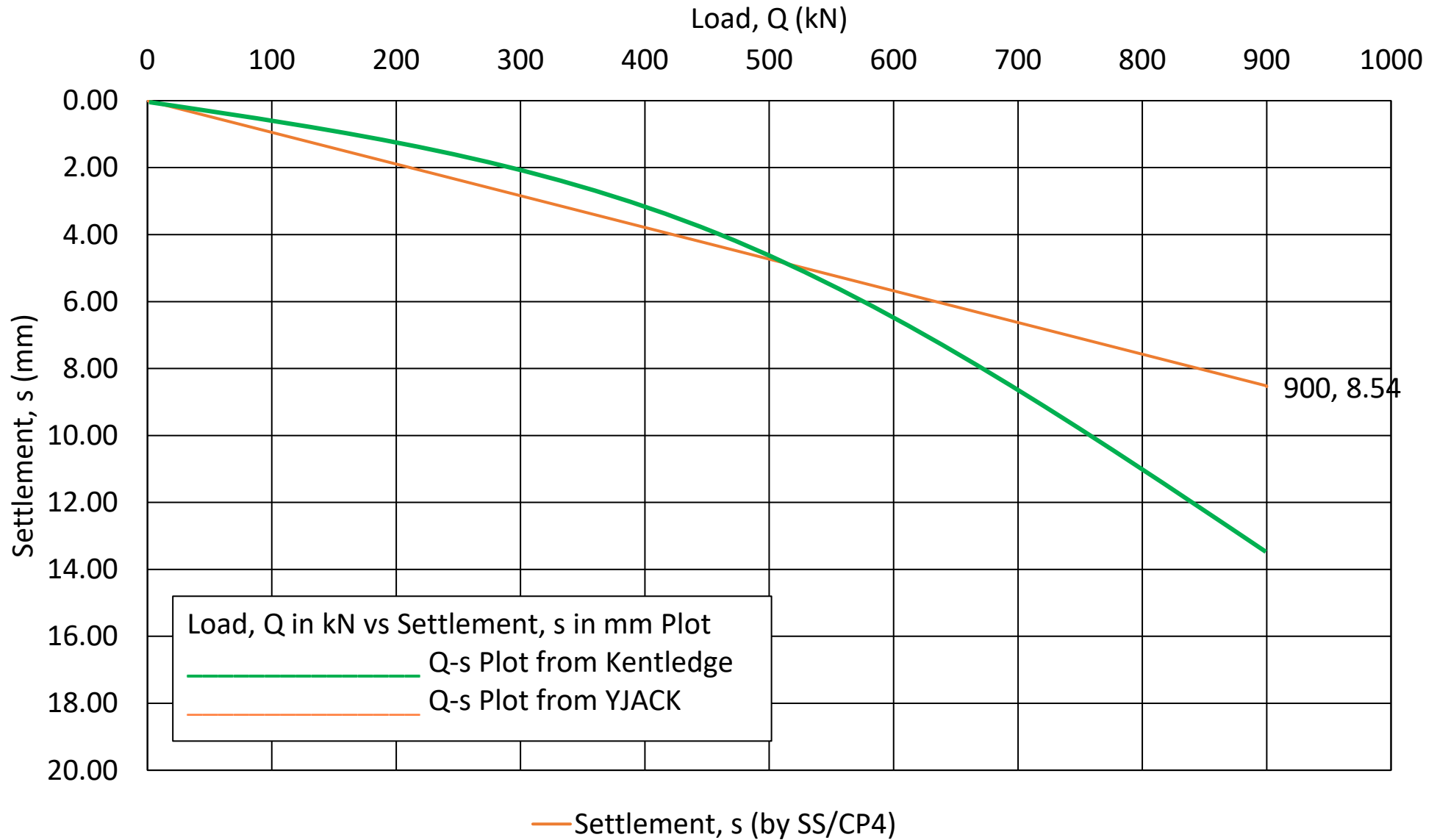

APPENDIX D

Field Sheets

Thick documents. Will be furnished upon request.

APPENDIX E

Project: Maintain Load test at Muar

Summary of Test Pile Record

Pile No.	Pile Top Settlement (mm)					
	1st Cycle		2nd Cycle		3rd Cycle	
	100%	0%	200%	0%	300%	0%
1A	3.53	1.09	7.33	1.59	11.17	2.34
1B	3.32	0.50	6.64	0.51	14.94	3.03
2A	4.00	0.53	7.93	1.15		
2B	3.43	0.09	7.63	0.98		

In Correlation Study, shall take the Q-s Plot with 0-offset in settlement.

Muar
 FIGURE 2 : LOAD VS SETTLEMENT CURVE
 Test Pile Top 1A, 300mm dia Spun Pile

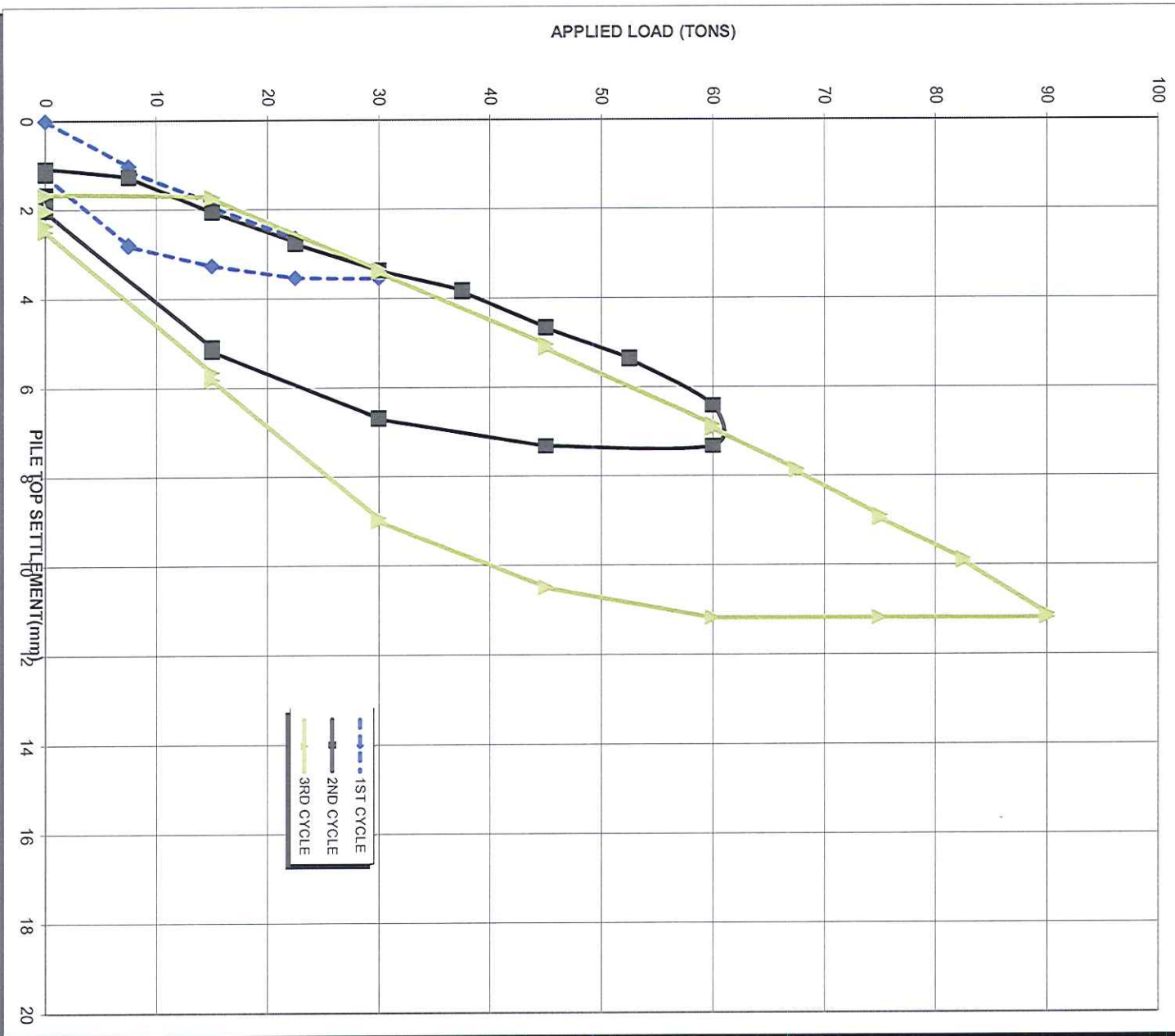

MUAR
FIGURE 2 : LOAD VS SETTLEMENT CURVE
Test Pile Top 1B, 300mm dia Spun Pile

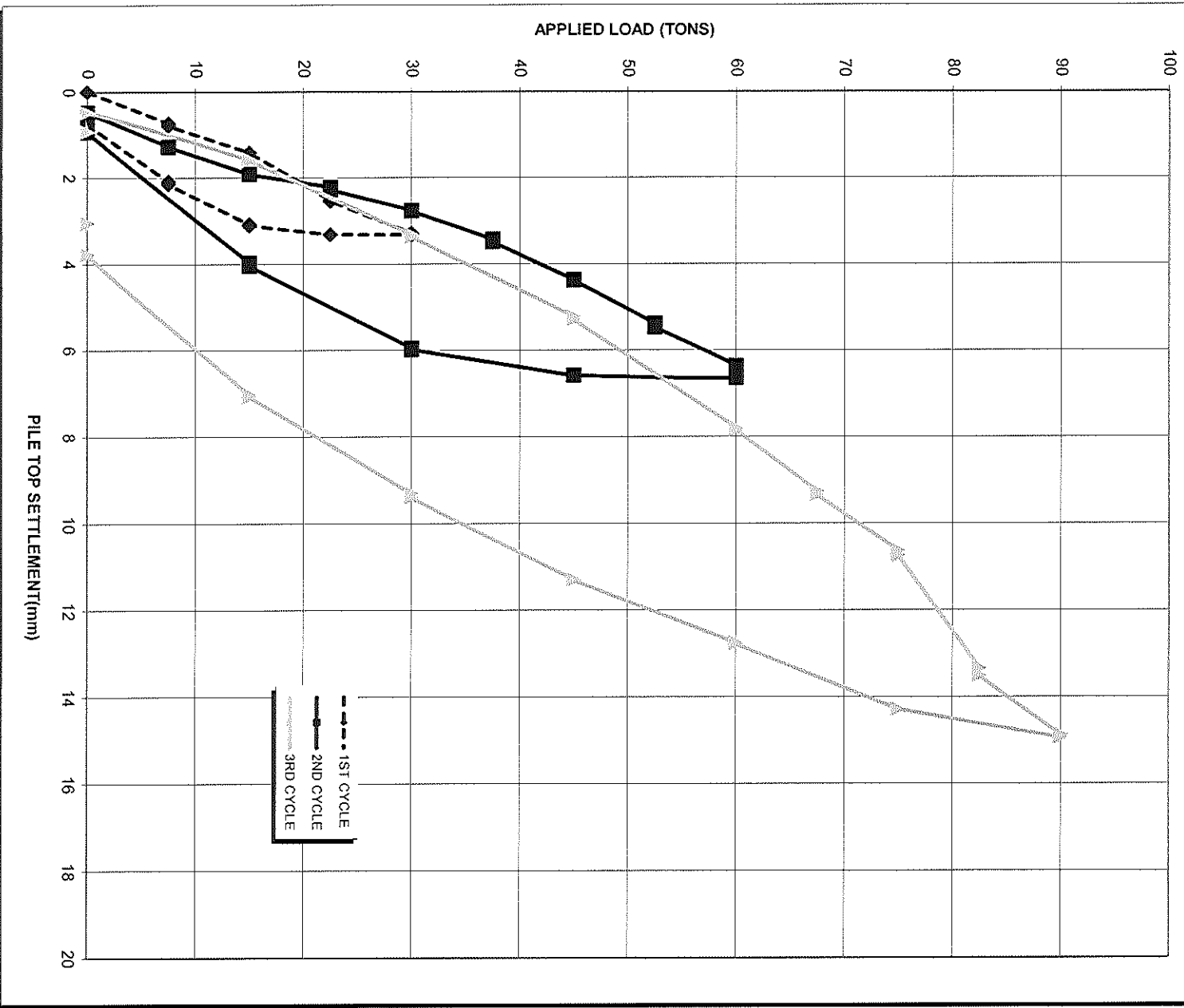

Muar
FIGURE 2 : LOAD VS SETTLEMENT CURVE
Test Pile Top 2A, 300mm Spun Pile

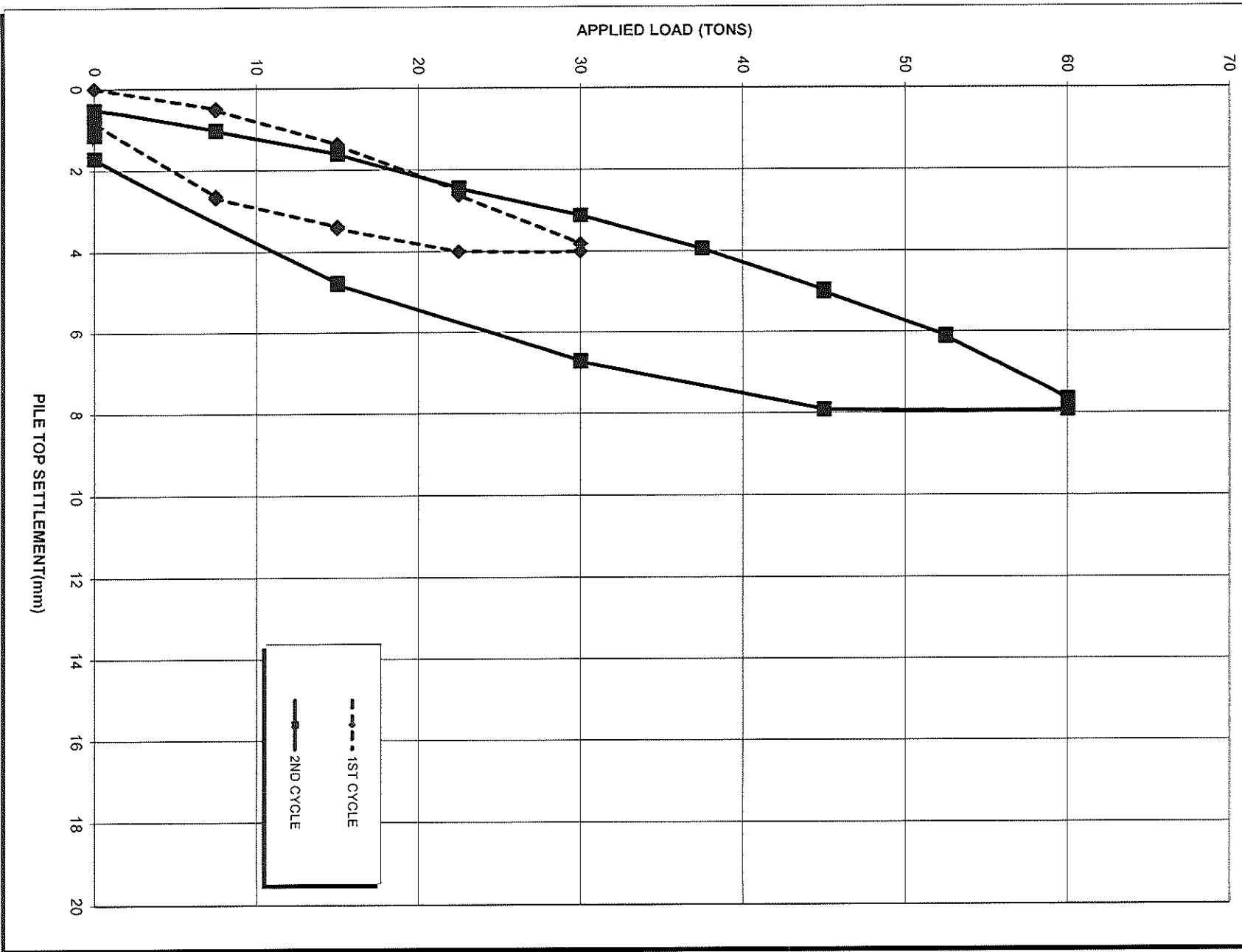

Muar
FIGURE 2 : LOAD VS SETTLEMENT CURVE
 Test Pile Top 2B, 300mm Spun Pile

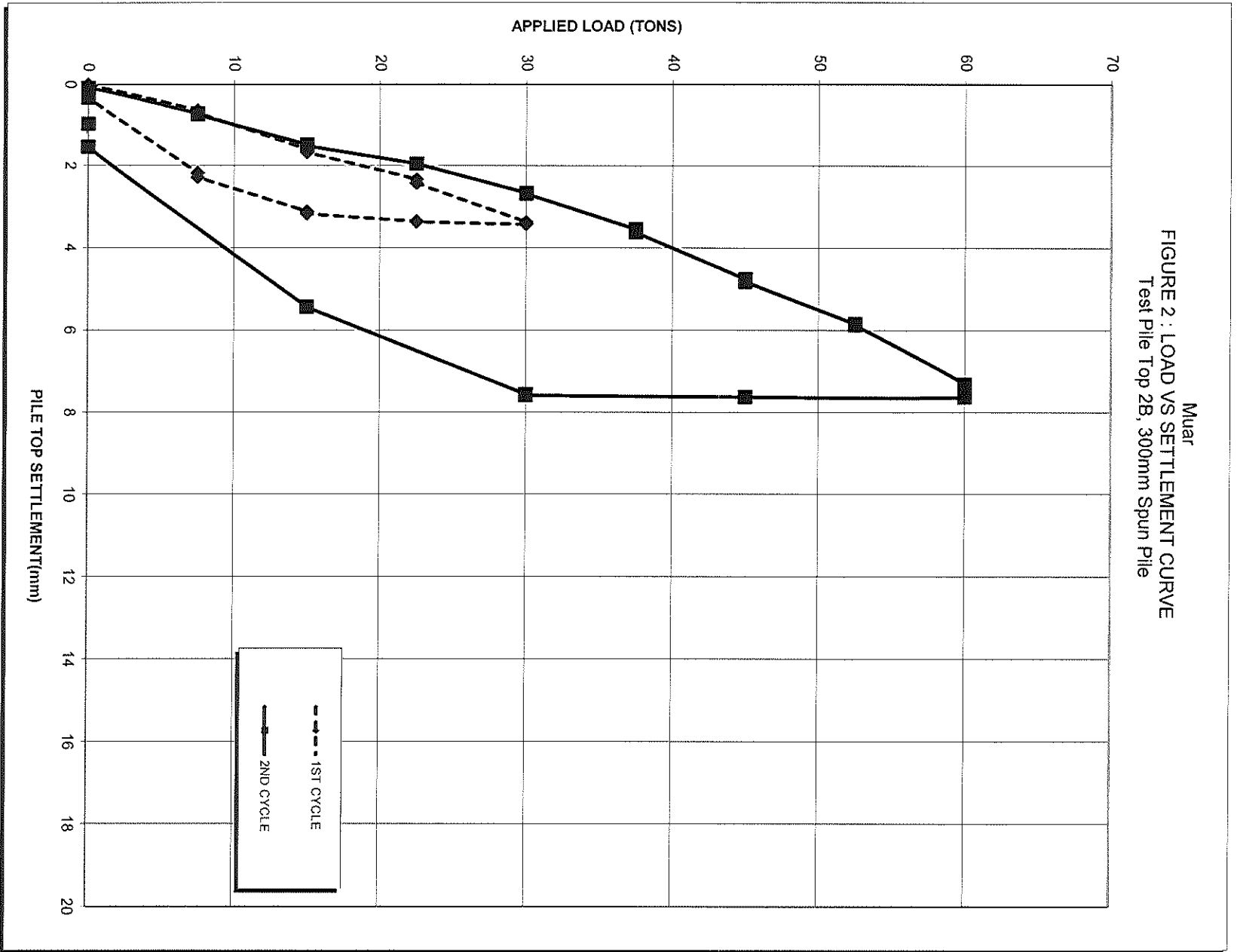

ATTACHMENT A

**Standard Operating Procedure (SOP) for Technical and Project Department
Constructing YJACK Q-s Plot from BD Pile Testing**

Note/01

The $W(up)$ is a constant value. In relatively small working load and long pile condition, the early few loading steps may have low loading, but after considerations to subtract the measured Q value with $W(up)$, the Q - D data points may have negative values to indicate "negative friction", in which this does not make sense. Hence in YJACK Plot Method, ignored $W(up)$ in plotting the Q - D Plot and considered this $W(up)$ in-conjunction with tension-compression factor to evaluate Q_u value.

Note/02

Follow Malaysian Local Practise. Refer to OCELL Test Report appendix.

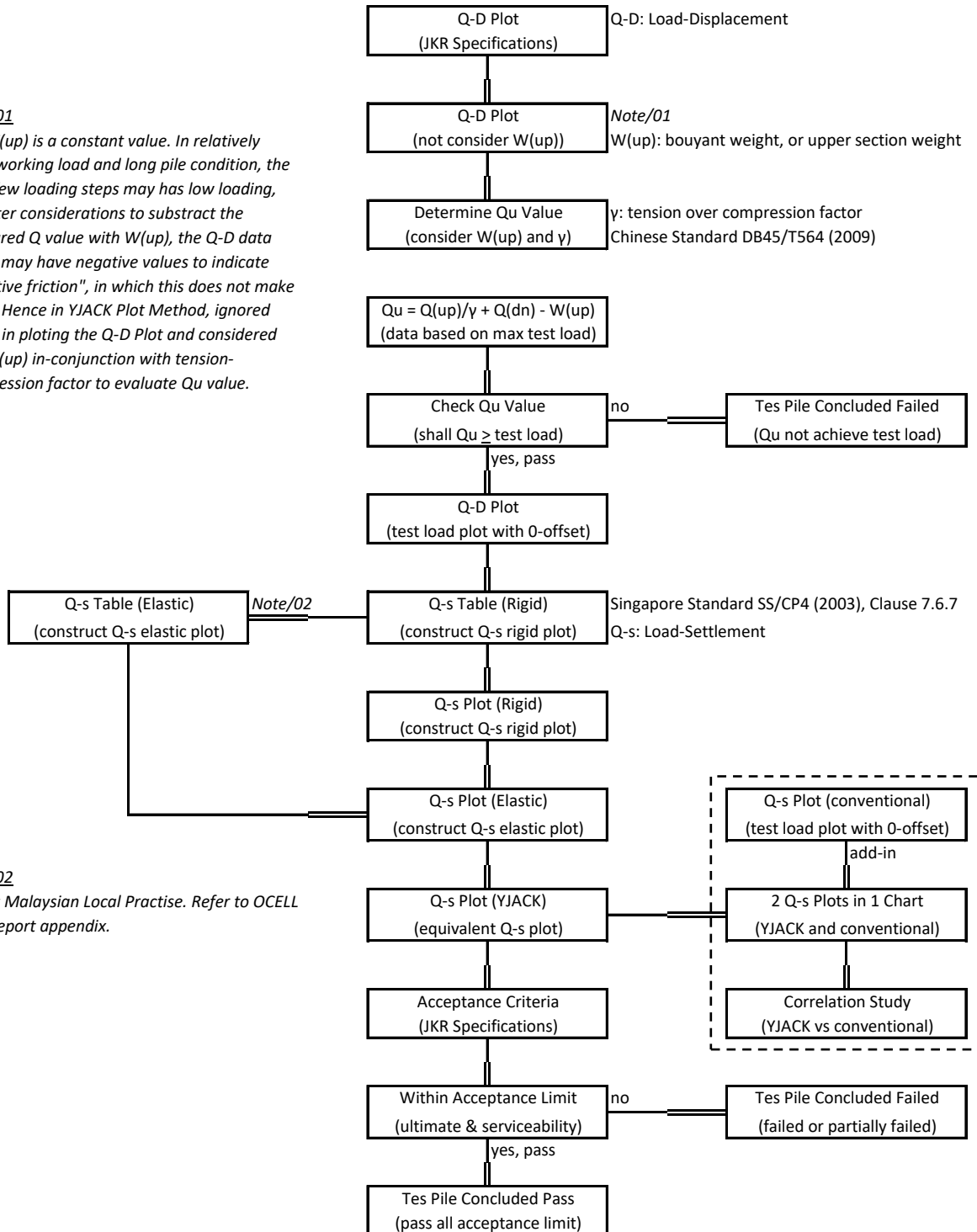

This SOP shall be deemed as YJACK Plot Method in constructing Q-s Plot from BD Testing (i.e. YPLOT Method).

Authorized By: Chief Executive Officer	Managed By: Chief Technical Officer	Effective Date: 2017/03/08
--	-------------------------------------	----------------------------

CONSTRUCTION OF THE EQUIVALENT TOP-LOADED LOAD-SETTLEMENT CURVE FROM THE RESULTS OF BI-DIRECTIONAL LOAD TEST (BDLT)

Introduction:

BDLT can provide a good estimate of a curve showing the load versus settlement of a top-loaded driven or bored pile (drilled shaft) with the following assumptions, which is consider good sense and usually conservative:

1. The end bearing load-movement curve in a top-loaded shaft has the same loads for a given movement as the net (subtract buoyant weight of pile above hydraulic jack) end bearing load-movement curve developed by the bottom of the hydraulic jack when placed at or near the bottom of the shaft.
2. The side shear load-movement curve in a top-loaded shaft has the same net shear, multiplied by an adjustment factor 'F' for a given downward movement as occurred in the BDLT for that same movement at the top of the jack in the upward direction. The same applies to the upward movement in a top-loaded tension test. Unless noted otherwise, a factor $F=0.95$ for compression in cohesionless soils and $F=0.80$ for tension tests in all soils is used.
3. The pile behaves as a rigid body, but includes the elastic compressions that are part of the movement data obtained from a bidirectional load test (BDLT). Procedure 1 interprets an equivalent top-load test (TLT) movement curve and procedure 2 corrects the effects of the additional elastic compressions in a TLT.
4. The part of the shaft below the hydraulic jack (one or multi level) has the same load-movement behavior as when top-loading the entire shaft. The subsequent 'end bearing movement curve' refers to the movement of the entire length of shaft below the jack.

Procedure 1:

Figure A shows BDLT results and Figure B shows the construction of equivalent top loaded settlement curve. Each of the curves shown has points numbered from 1 to 12 such that the same point number on each curve has the same movement magnitude.

With the above assumptions, the equivalent curve can be constructed as follows:

Select an arbitrary movement such as the 0.40 inches to give point 4 on the shaft side shear load movement curve in Figure A and record the load of 2,090 tons in shear at that movement. With the initial assumption of a rigid pile, the top of pile moves downward the same as the bottom. Therefore, find point 4 with 0.40 inches of upward movement on the end bearing load movement curve and record the corresponding load of 1,060 tons.

Adding these two loads will give the total load of 3,150 tons due to side shear plus end bearing at the same movement and thus gives point 4 on the Figure B load settlement curve for an equivalent top-loaded test. Procedure 1 can be used to obtain all the points in Figure B up to the component that moved the least at the end of the test, in this case point 5 in side shear.

Suitable hyperbolic curve fitting technique can be used for extrapolation of the side shear curve to produce end bearing movement data up to 12. Some judgment is required for deciding on the maximum number of data points to provide good fit with high correlation coefficient, r^2 . Using the same movement matching procedure described earlier, the equivalent curve to points 6 to 12 can be extended. The dashed line shown in Figure B, signify that this part of the equivalent curve depends partly on extrapolated data.

If the data warrants, the extrapolations of both side shear and end bearing to extend the equivalent curve to a greater movement than the maximum measured (point 12) will be used. An appendix in this report gives the details of the extrapolation(s) used with the present BDLT and shows the fit with the actual data.

Procedure 2:

The elastic compression in the equivalent top load test always exceeds that in the BDLT. It produces more top movement and also additional side shear movement, which then generate more side shear, more compression, etc. An exact solution of this load transfer problem requires knowing the side shear vs. vertical movement (t-y) curves for a large number of pile length increments and solving the resulting set of simultaneous equations or using finite element or finite difference simulations to obtain an approximate solution for these equations.

The attached analysis P.6 gives the equations for the elastic compressions that occur in the BDLT with one or two levels of hydraulic jacks. Analysis P.7 gives the equations for the elastic compressions that occur in the equivalent TLT. Both sets of equations do not include the elastic compression below the hydraulic jack because the same compression takes place in both the BDLT and the TLT. This is equivalent to taking $I_3 = 0$. Subtracting the BDLT from the TLT compression gives the desired additional elastic compression at the top of the TLT. The additional elastic compression is then added to the 'rigid' equivalent curve obtained from Part 1 to obtain the final, corrected equivalent load-settlement curve for the TLT on the same pile as the actual BDLT.

Note that the above p.6 and p.7 give equations for each of three assumed patterns of developed side shear stress along the pile. The pattern shown in the center of the three is applicable to any approximate determined side shear distribution. Experience has shown the initial solution for the additional elastic compression, as described above, gives an adequate and slightly conservative (high) estimate of the additional compression versus more sophisticated load-transfer analyses as described in the first paragraph of this Part II.

The analysis p.8 provides an example of calculated results in English units on a hypothetical 1-stage, single level BDLT using the simplified method in Part II with the centroid of the side shear distribution 44.1% above the base of the hydraulic jack. Figure C compares the corrected with the rigid curve of Figure B. Page 9 contains an example equivalent to that above in SI units.

The final analysis p.10 provides an example of calculated results in English units on a hypothetical 3-stage, multi level BDSLT using the simplified method in Part II with the centroid of the combined upper and middle side shear distribution 44.1% above the base of the bottom hydraulic jack. The individual centroids of the upper and middle side shear distribution lie 39.6% and 57.9% above and below the middle hydraulic jack, respectively. Figure E compares the corrected with the rigid curve. Page 11 contains an example equivalent to that above in SI units.

Other Tests: The example illustrated in [Figure A](#) has the maximum component movement in end bearing. The procedures remain the same if the maximum test movement occurred in side shear. Then we would have extrapolated end bearing to produce the dashed-line part of the reconstructed top-load settlement curve.

The example illustrated also assumes a pile top-loaded in compression. For a pile top-loaded in tension we would, based on Assumptions 2 and 3, use the upward side shear load curve in [Figure A](#), multiplied by the $F = 0.80$ noted in Assumption 2, for the equivalent top-loaded displacement curve.

Expected Accuracy: There are only five series of tests that provide the data needed to make a direct comparison between actual, full scale, top-loaded pile movement behaviour and the equivalent behaviour obtained from a BDLT by the method described herein. These involved three sites in Japan and one in Singapore, in a variety of soils, with three compression tests on bored piles (drilled shafts), one compression test on a driven pile and one tension test on a bored pile. The largest bored pile had a 1.2 m diameter and a 37 m length. The driven pile had a 1-m increment modular construction and a 9 m length. The largest top loading = 28 MN (3,150 tons).

The following references detail the aforementioned Japanese tests and the results therefore:

Kishida H. *et al.*, 1992, "Pile Loading Tests at Osaka Amenity Park Project", Paper by Mitsubishi Co., also briefly described in Schmertmann (1993, see bibliography). Compares one drilled shaft in tension and another in compression.

Ogura, H. *et al.*, 1995, "Application of Pile Toe Load Test to Cast-in-place Concrete Pile and Precast Pile", special volume 'Tsuchi-to-Kiso' on Pile Loading Test, Japanese Geotechnical Society, Vol. 3, No. 5, Ser. No. 448. Original in Japanese. Translated by M.B. Karkee, GEOTOP Corporation. Compares one drilled shaft and one driven pile, both in compression.

We compared the predicted equivalent and measured top load at three top movements in each of the above four Japanese comparisons. The top movements ranged from ¼ inch (6 mm) to 40 mm, depending on the data available.

The (equiv./meas.) ratios of the top load averaged 1.03 in the 15 comparisons with a coefficient of variation of less than 10%. These available comparisons help support the practical validity of the equivalent top load method described herein.

L.S. Peng, A.M. Koon, R. Page and C. W. Lee report the results of a class-A prediction by others of the TLT curve from a BDLT on a 1.2 m diameter, 37.2 m long bored pile in Singapore, compared to an adjacent pile with the same dimensions actually top-loaded by kentledge. They report about a 4% difference in ultimate capacity and less than 8% difference in settlements over the 1.0 to 1.5 times working load range – comparable to the accuracy noted above. Their paper was published in March 1999 in the Proceedings of the International Conference on Rail Transit, held in Singapore and published by the Association of Consulting Engineers Singapore.

B.H. Fellenius has made several finite element method (FEM) studies of a BDLT in which he adjusted the parameters to produce good load-deflection matches with the BDLT up and down load-deflection curve. He then used the same parameters to predict the TLT deflection curve. We compared the FEM-predicted curve with the equivalent load-deflection predicted by the previously described Part I and II procedures, with the results again comparable to the accuracy noted above. A paper by Fellenius *et. al.* titled "BDLT and FE Analysis of a 28 m Deep Barrette in Manila, Philippines", awaiting publication in the ASCE Journal of Geotechnical and Environmental Engineering, details one of the comparisons.

Limitations: The engineer using these results should judge the conservatism of the aforementioned assumptions and extrapolation(s) before utilizing the results for design purposes. For example, brittle failure behaviour may produce movement curves with abrupt changes in curvature (not hyperbolic). However, the hyperbolic fit method and the assumptions used usually produce reasonable equivalent top load settlement curves.

Example of the Construction of an Equivalent Top-Loaded Settlement Curve (Figure B)
From BDLT Results (Figure A)

Figure A

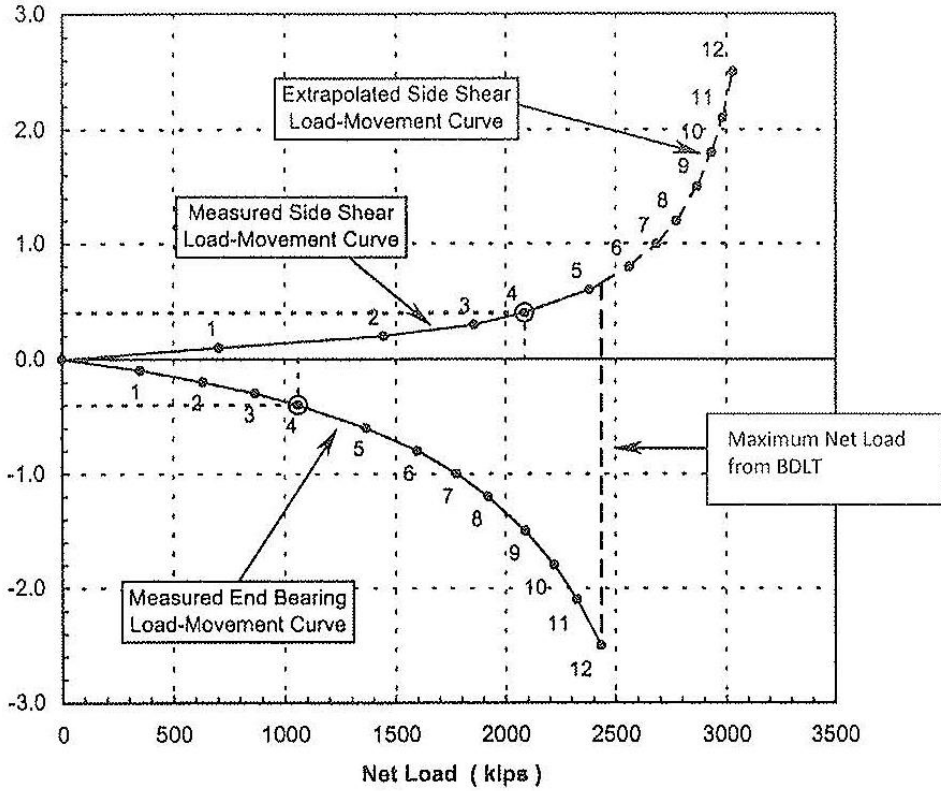
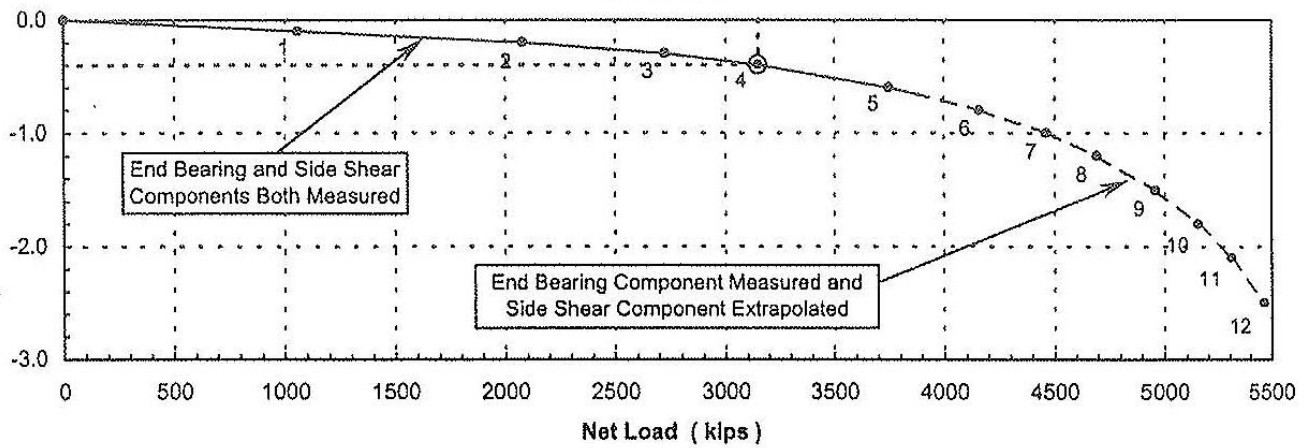
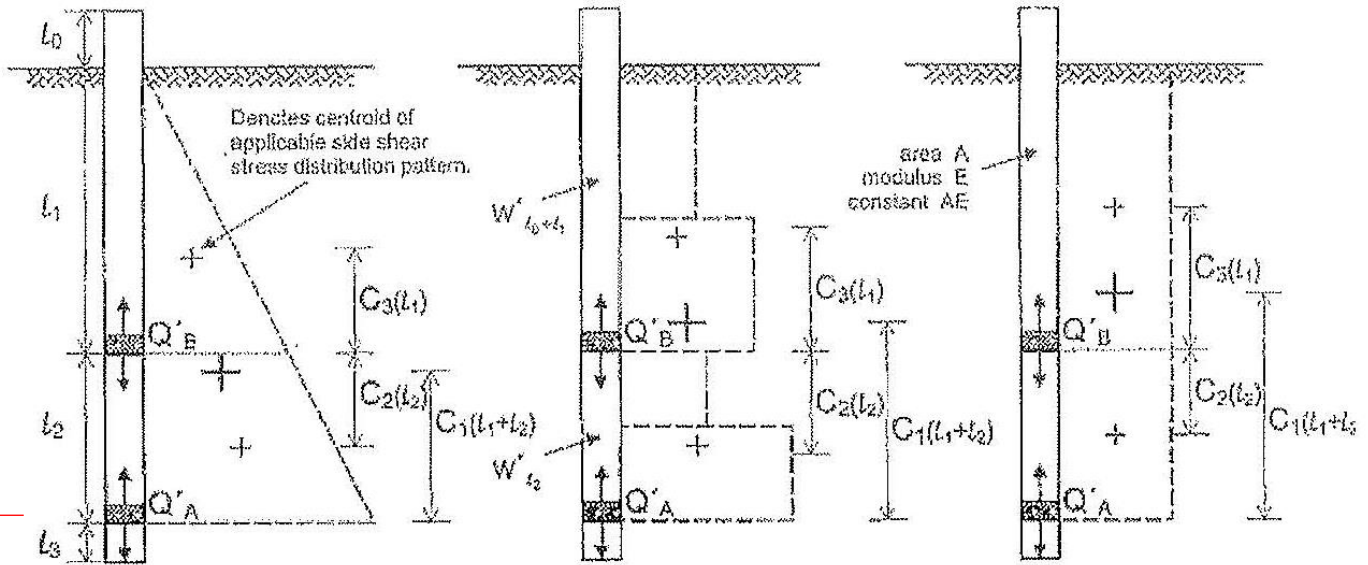

Figure B



Theoretical Elastic Compression in BDLT
Based on Pattern of Development Side Shear Stress



1-Stage Single Level Test (Q'_A only):

$$\delta_{BDLT} = \delta_{\uparrow e1} + \delta_{\downarrow e2}$$

$C_1 = \frac{1}{3}$	Centroid Factor = C_1	$C_1 = \frac{1}{2}$
$\delta_{T(l_1+l_2)} = \frac{1}{3} \frac{Q'_{TA} (l_1 + l_2)}{AE}$	$\delta_{T(l_1+l_2)} = C_1 \frac{Q'_{TA} (l_1 + l_2)}{AE}$	$\delta_{T(l_1+l_2)} = \frac{1}{2} \frac{Q'_{TA} (l_1 + l_2)}{AE}$

3-Stage Multi Level Test (Q'_A and Q'_B):

$$\delta_{BDLT} = \delta_{\uparrow e1} + \delta_{\downarrow e2}$$

$C_3 = \frac{1}{3}$	Centroid Factor = C_3	$C_3 = \frac{1}{2}$
$\delta_{Tl_1} = \frac{1}{3} \frac{Q'_{TB} l_1}{AE}$	$\delta_{Tl_1} = C_3 \frac{Q'_{TB} l_1}{AE}$	$\delta_{Tl_1} = \frac{1}{3} \frac{Q'_{TB} l_1}{AE}$
$C_2 = \frac{1}{3} \left(\frac{3l_1 + 2l_2}{2l_1 + l_2} \right)$	Centroid Factor = C_2	$C_2 = \frac{1}{2}$
$\delta_{\downarrow l_2} = \frac{1}{3} \left(\frac{3l_1 + 2l_2}{2l_1 + l_2} \right) \frac{Q'_{\downarrow B} l_2}{AE}$	$\delta_{\downarrow l_2} = C_2 \frac{Q'_{\downarrow B} l_2}{AE}$	$\delta_{\downarrow l_2} = \frac{1}{2} \frac{Q'_{\downarrow B} l_2}{AE}$

Net Loads:

$$Q'_{TA} = Q_{TA} - W'_{l_0+l_1+l_2}$$

$$Q'_{TB} = Q_{TB} - W'_{l_0+l_1}$$

$$Q'_{\downarrow B} = Q_{\downarrow B} + W'_{l_2}$$

W' = pile weight, buoyant where below water table

Q'_B is the 2nd level BD-JACK.
In YJACK Validation Program, only single level (1) YJACK installed, hence ignored Q'_B level.
Only consider Q'_A level.

Theoretical Elastic Compression in Top Loaded Test
Based on Pattern of Development Side Shear Stress

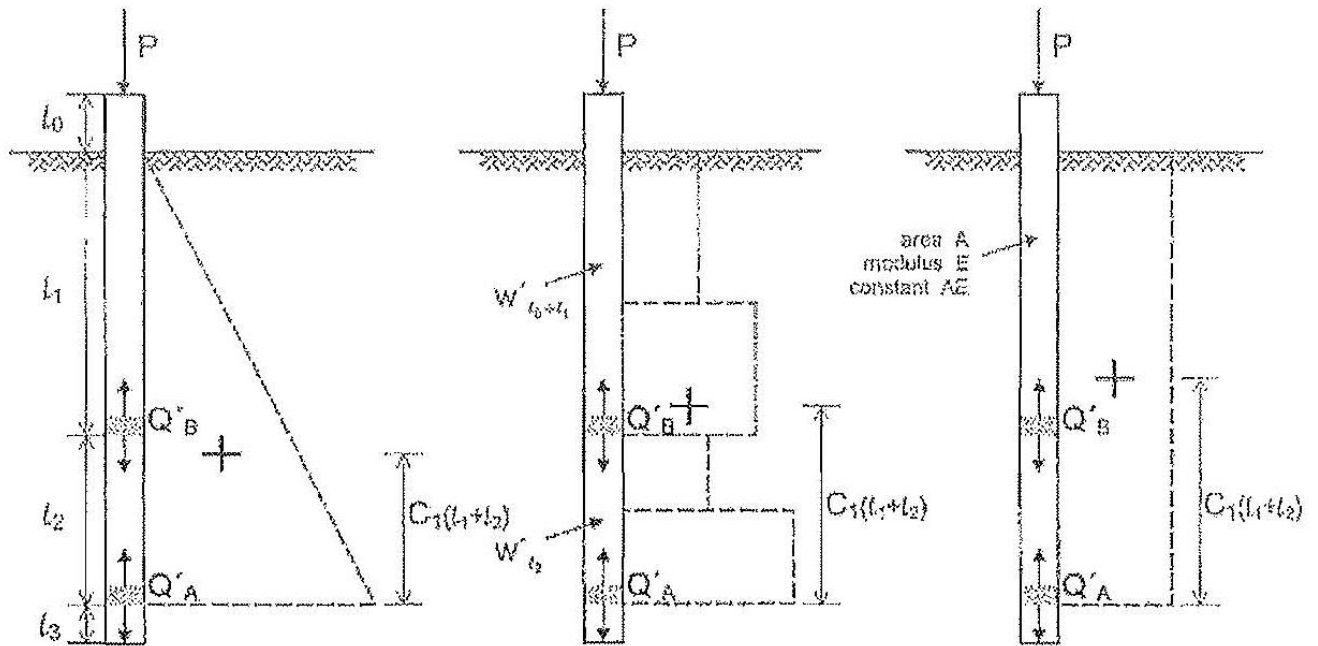

Top Loaded Test: $\delta_{TLT} = \delta_{l_0} + \delta_{l_1+l_2}$

$\delta_{l_0} = \frac{Pl_0}{AE}$	$\delta_{l_0} = \frac{Pl_0}{AE}$	$\delta_{l_0} = \frac{Pl_0}{AE}$
$C_1 = \frac{1}{3}$	Centroid Factor = C_1	$C_1 = \frac{1}{2}$
$\delta_{l_1+l_2} = \frac{(Q'_{1A} + 2P)(l_1 + l_2)}{3AE}$	$\delta_{l_1+l_2} = \frac{[(C_1)Q'_{1A} + (1-C_1)P](l_1 + l_2)}{AE}$	$\delta_{l_1+l_2} = \frac{(Q'_{1A} + P)(l_1 + l_2)}{2AE}$

Net and Equivalent Loads:

$$Q'_{1A} = Q_{1A} - W'_{l_0+l_1+l_2}$$

$$P_{\text{single}} = Q'_{1A} + Q'_{1B}$$

$$P_{\text{multi}} = Q'_{1A} + Q'_{1B} + Q'_{1C}$$

Component loads Q selected at the same (\pm) Δ_{BDSLIT} .

ATTACHMENT B

CONTROLLED COPY

Please refer to separate document.

ATTACHMENT C

CALIBRATION CERTIFICATE

Cert. No. : KP/15/0153-1 **Job No.** : KCW099115

Date of Issue : 25-Apr-15 **Page** : 1 of 1

Customer : YJACK TECHNOLOGY SDN BHD
 LEVEL 16, 1 SENTRAL, KL SENTRAL,
 50470 KUALA LUMPUR, MALAYSIA

Date Received : 24-Apr-15
Date Calibrated : 25-Apr-15
Calibration Due Date* : 25-Apr-16
Ambient Temperature : 20°C ± 2°C
Relative Humidity : 55% r.h. ± 10% r.h.

Instrument : PRESSURE GAUGE

Serial No. : ---
Tag / ID No. : 908
Range : (0 to 10000 psi gauge)
Resolution : 100 psi/div.

Manufacturer : ENERPAC

Model No. : G4039L

"This laboratory is accredited in accordance with recognized International Standard ISO/IEC 17025:2005. This accreditation demonstrates technical competence for a defined scope and the operation of a laboratory quality management system (refer joint ISO-ILAC-IAF Communiqué dated 18 June 2005)."

The described instrument has been checked and calibrated at **NORTHLAB SEAMS (M) SDN BHD** under the ambient conditions stated above.

METHOD OF CALIBRATION

- The method of calibration is as per method no. P08 in NLLQM/001/12 of the Quality Manual.

	<u>Standard instrument used</u>	<u>Serial No.</u>	<u>Traceability</u>	<u>Via Cert No.</u>	<u>Due Date</u>
1	Hydraulic Dead Weight Tester	23703/480	NML(M'SIA)	NML/1728/M/14	07-Jul-17

RESULTS OF CALIBRATION

APPLIED EQUIVALENT VALUE (psi)	INSTRUMENT READING (psi)							
	INCREASING				DECREASING			
	<i>Before Adj.</i>		<i>After Adj.</i>		<i>Before Adj.</i>		<i>After Adj.</i>	
	<i>Rdg</i>	<i>Error</i>	<i>Rdg</i>	<i>Error</i>	<i>Rdg</i>	<i>Error</i>	<i>Rdg</i>	<i>Error</i>
0.0	0	0.0	---	---	0	0.0	---	---
1,994.6	2,000	5.4	---	---	2,000	5.4	---	---
3,989.3	4,000	10.7	---	---	4,000	10.7	---	---
5,983.9	6,000	16.1	---	---	6,000	16.1	---	---
7,978.6	8,000	21.4	---	---	8,000	21.4	---	---
9,973.2	10,000	26.8	---	---	---	---	---	---

- The estimated uncertainty of measurement to be associated with the results is ± 13 psi, calculated at a level of confidence of approximately 95% with a coverage factor of k=2.

REMARKS

- The user should decide on the usability of this instrument.
- *Recalibration date specified by customer.
- The user should be aware that any number of factors may cause this instrument to drift out of calibration before the specified calibration interval has expired.

Calibrated by

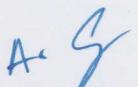

A.GANDHY

Approved Signatory

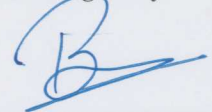

BIJIN

CALIBRATION CERTIFICATE

Cert. No. : KD/15/0427-6	Job No. : KCW099115
Date of Issue : 28-Apr-15	Page : 1 of 2

Customer : **YJACK TECHNOLOGY SDN BHD**
LEVEL 16, 1 SENTRAL, KL SENTRAL,
50470 KUALA LUMPUR, MALAYSIA

Date Received : 24-Apr-15
Date Calibrated : 28-Apr-15
Calibration Due Date* : 28-Apr-16
Ambient Temperature : 20 ± 1°C
Relative Humidity : 55 ± 5% r.h.

Instrument : **DIAL GAUGE**

Serial No. : SXD 860
Tag No. : ---
Cal Range : 0 ~ 50 mm
Resolution : 0.01 mm

Manufacturer : MITUTOYO
Model No. : 3058S-19

This laboratory is accredited in accordance with recognized international standard ISO/IEC 17025:2005. This accreditation demonstrates technical competence for a defined scope and the operation of a laboratory quality management system (refer joint ISO-ILAC-IAF communique dated 18 June 2005).

The described instrument has been checked and calibrated at **NORHLAB SEAMS (M) SDN BHD** under the ambient conditions stated above.

METHOD OF CALIBRATION

- The instrument was calibrated as per method no. Procedure-017 in NLQM/001/10 of the Quality Manual and with reference to Digimatic Indicators and Linear Gauges as a guide.

<u>Standard instrument used</u>	<u>Serial No.</u>	<u>Traceability</u>	<u>Via Cal.Cert.No</u>	<u>Due date</u>
1. Gauge Block Set	0800165	NPL(UK)	ML/2013/0408	11-Jun-15

RESULTS OF CALIBRATION

- The results of calibration are given on the attached calibration data sheet(s).

REMARKS

- The user should decide on the usability of this instrument.
- *Recalibration date specified by client.
- The user should be aware that any number of factors may cause this instrument to drift out of calibration before the specified calibration interval has expired.

Calibrated by

Approved Signatory

HAYATI Bt SEMAN

AZHAR BIN SALMAN

CALIBRATION CERTIFICATE

Cert No. :	KD/15/0427-6	Job No. :	KCW099115
Date of Issue :	28-Apr-15	Page :	2 of 2

RESULTS OF CALIBRATION

<i>FEATURE INSPECTED : ACCURACY</i>	
<i>NOMINAL VALUE (mm)</i>	<i>MEASURED VALUE (mm)</i>
0	0.000
5	5.000
10	10.000
15	15.000
20	20.000
25	25.000
30	30.000
35	35.000
40	40.000
45	44.998
50	49.998
REPEATABILITY	0.002 mm

- The expanded measurement uncertainty associated with the results is ± 0.001 mm estimated at a level of confidence of approximately 95% with a coverage factor of $k = 2$.

Calibrated by

Approved Signatory

HAYATI BT SEMAN

AZHAR BIN SALMAN

CALIBRATION CERTIFICATE

Cert. No. : KD/15/0427-2	Job No. : KCW099115
Date of Issue : 28-Apr-15	Page : 1 of 2

Customer : **YJACK TECHNOLOGY SDN BHD**
LEVEL 16, 1 SENTRAL, KL SENTRAL,
50470 KUALA LUMPUR, MALAYSIA

Date Received : 24-Apr-15
Date Calibrated : 28-Apr-15
Calibration Due Date* : 28-Apr-16
Ambient Temperature : 20 ± 1°C
Relative Humidity : 55 ± 5% r.h.

Instrument : **DIAL GAUGE**

Serial No. : SXD 865

Manufacturer : MITUTOYO

Tag No. : ---

Model No. : 3058S-19

Cal Range : 0 ~ 50 mm

Resolution : 0.01 mm

This laboratory is accredited in accordance with recognized international standard ISO/IEC 17025:2005. This accreditation demonstrates technical competence for a defined scope and the operation of a laboratory quality management system (refer joint ISO-ILAC-IAF communique dated 18 June 2005).

The described instrument has been checked and calibrated at **NORTHLAB SEAMS (M) SDN BHD** under the ambient conditions stated above.

METHOD OF CALIBRATION

- The instrument was calibrated as per method no. Procedure-017 in NLQM/001/10 of the Quality Manual and with reference to Digimatic Indicators and Linear Gauges as a guide.

	<u>Standard instrument used</u>	<u>Serial No.</u>	<u>Traceability</u>	<u>Via Cal.Cert.No</u>	<u>Due date</u>
1.	Gauge Block Set	0800165	NPL(UK)	ML/2013/0408	11-Jun-15

RESULTS OF CALIBRATION

- The results of calibration are given on the attached calibration data sheet(s).

REMARKS

- The user should decide on the usability of this instrument.
- *Recalibration date specified by client.
- The user should be aware that any number of factors may cause this instrument to drift out of calibration before the specified calibration interval has expired.

Calibrated by

Approved Signatory

HAYATI BT SEMAN

AZHAR BIN SALMAN

CALIBRATION CERTIFICATE

Cert No. : KD/15/0427-2

Job No. : KCW099115

Date of Issue : 28-Apr-15

Page : 2 of 2

RESULTS OF CALIBRATION

<i>FEATURE INSPECTED : ACCURACY</i>	
<i>NOMINAL VALUE (mm)</i>	<i>MEASURED VALUE (mm)</i>
0	0.000
5	5.000
10	10.000
15	15.002
20	20.000
25	25.000
30	30.000
35	35.000
40	40.000
45	45.000
50	50.000
<i>REPEATABILITY</i>	
<i>0.002 mm</i>	

- The expanded measurement uncertainty associated with the results is ± 0.001 mm estimated at a level of confidence of approximately 95% with a coverage factor of $k = 2$.

Calibrated by

Approved Signatory

HAYATI BT SEMAN

AZHAR BIN SALMAN

CALIBRATION CERTIFICATE

Cert. No. : KD/15/0427-5	Job No. : KCW099115
Date of Issue : 28-Apr-15	Page : 1 of 2

Customer : **YJACK TECHNOLOGY SDN BHD**
LEVEL 16, 1 SENTRAL, KL SENTRAL,
50470 KUALA LUMPUR, MALAYSIA

Date Received : 24-Apr-15
Date Calibrated : 28-Apr-15
Calibration Due Date* : 28-Apr-16
Ambient Temperature : 20 ± 1°C
Relative Humidity : 55 ± 5% r.h.

Instrument : **DIAL GAUGE**

Serial No. : SXD 868

Manufacturer : MITUTOYO

Tag No. : ---

Model No. : 3058-19

Cal Range : 0 ~ 50 mm

Resolution : 0.01 mm

This laboratory is accredited in accordance with recognized international standard ISO/IEC 17025:2005. This accreditation demonstrates technical competence for a defined scope and the operation of a laboratory quality management system (refer joint ISO-ILAC-IAF communique dated 18 June 2005).

The described instrument has been checked and calibrated at **NORTHLAB SEAMS (M) SDN BHD** under the ambient conditions stated above.

METHOD OF CALIBRATION

- The instrument was calibrated as per method no. Procedure-017 in NLQM/001/10 of the Quality Manual and with reference to Digimatic Indicators and Linear Gauges as a guide.

<u>Standard instrument used</u>	<u>Serial No.</u>	<u>Traceability</u>	<u>Via Cal.Cert.No</u>	<u>Due date</u>
1. Gauge Block Set	0800165	NPL(UK)	ML/2013/0408	11-Jun-15

RESULTS OF CALIBRATION

- The results of calibration are given on the attached calibration data sheet(s).

REMARKS

- The user should decide on the usability of this instrument.
- *Recalibration date specified by client.
- The user should be aware that any number of factors may cause this instrument to drift out of calibration before the specified calibration interval has expired.

Calibrated by

Approved Signatory

HAYATI ET SEMAN

AZHAR BIN SALMAN

CALIBRATION CERTIFICATE

Cert No. : KD/15/0427-5

Job No. : KCW099115

Date of Issue : 28-Apr-15

Page : 2 of 2

RESULTS OF CALIBRATION

<i>FEATURE INSPECTED : ACCURACY</i>	
<i>NOMINAL VALUE (mm)</i>	<i>MEASURED VALUE (mm)</i>
0	0.000
5	5.002
10	10.000
15	15.002
20	20.000
25	25.000
30	30.000
35	35.000
40	40.000
45	45.002
50	50.000
<i>REPEATABILITY</i>	<i>0.002 mm</i>

- The expanded measurement uncertainty associated with the results is $\pm 0.001\text{mm}$ estimated at a level of confidence of approximately 95% with a coverage factor of $k = 2$.

Calibrated by

Approved Signatory

HAYATI BT SEMAN

AZHAR BIN SALMAN

CALIBRATION CERTIFICATE

Cert. No. : KD/15/0427-4	Job No. : KCW099115
Date of Issue : 28-Apr-15	Page : 1 of 2

Customer : YJACK TECHNOLOGY SDN BHD
LEVEL 16, 1 SENTRAL, KL SENTRAL,
50470 KUALA LUMPUR, MALAYSIA

Date Received : 24-Apr-15
Date Calibrated : 28-Apr-15
Calibration Due Date* : 28-Apr-16
Ambient Temperature : 20 ± 1°C
Relative Humidity : 55 ± 5% r.h.

Instrument : DIAL GAUGE

Serial No. : SXD 869

Tag No. : ---

Manufacturer : MITUTOYO

Cal Range : 0 ~ 50 mm

Model No. : 3058S-19

Resolution : 0.01 mm

This laboratory is accredited in accordance with recognized international standard ISO/IEC 17025:2005. This accreditation demonstrates technical competence for a defined scope and the operation of a laboratory quality management system (refer joint ISO-ILAC-IAF communique dated 18 June 2005).

The described instrument has been checked and calibrated at **NORTHLAB SEAMS (M) SDN BHD** under the ambient conditions stated above.

METHOD OF CALIBRATION

- The instrument was calibrated as per method no. Procedure-017 in NLQM/001/10 of the Quality Manual and with reference to Digimatic Indicators and Linear Gauges as a guide.

<u>Standard instrument used</u>	<u>Serial No.</u>	<u>Traceability</u>	<u>Via Cal.Cert.No</u>	<u>Due date</u>
1. Gauge Block Set	0800165	NPL(UK)	ML/2013/0408	11-Jun-15

RESULTS OF CALIBRATION

- The results of calibration are given on the attached calibration data sheet(s).

REMARKS

- The user should decide on the usability of this instrument.
- *Recalibration date specified by client.
- The user should be aware that any number of factors may cause this instrument to drift out of calibration before the specified calibration interval has expired.

Calibrated by

Approved Signatory

 HAYATI BT SEMAN

 AZHAR BIN SALMAN

CALIBRATION CERTIFICATE

Cert No. : KD/15/0427-4

Job No. : KCW099115

Date of Issue : 28-Apr-15

Page : 2 of 2

RESULTS OF CALIBRATION

<i>FEATURE INSPECTED : ACCURACY</i>	
<i>NOMINAL VALUE (mm)</i>	<i>MEASURED VALUE (mm)</i>
0	0.000
5	4.998
10	10.000
15	14.998
20	20.000
25	25.000
30	30.000
35	35.000
40	40.000
45	44.998
50	49.998
<i>REPEATABILITY</i>	<i>0.002 mm</i>

- The expanded measurement uncertainty associated with the results is ± 0.001 mm estimated at a level of confidence of approximately 95% with a coverage factor of $k = 2$.

Calibrated by

Approved Signatory

HAYATI BT SEMAN

AZHAR BIN SALMAN

CALIBRATION CERTIFICATE

Cert. No. : KD/15/0427-3	Job No. : KCW099115
Date of Issue : 28-Apr-15	Page : 1 of 2

Customer : **YJACK TECHNOLOGY SDN BHD**
LEVEL 16, 1 SENTRAL, KL SENTRAL,
50470 KUALA LUMPUR, MALAYSIA

Date Received : 24-Apr-15
Date Calibrated : 28-Apr-15
Calibration Due Date* : 28-Apr-16
Ambient Temperature : 20 ± 1°C
Relative Humidity : 55 ± 5% r.h.

Instrument : **DIAL GAUGE**

Serial No. : SXD 881
Tag No. : ---
Cal Range : 0 ~ 50 mm
Resolution : 0.01 mm

Manufacturer : MITUTOYO
Model No. : 3058S-19

This laboratory is accredited in accordance with recognized international standard ISO/IEC 17025:2005. This accreditation demonstrates technical competence for a defined scope and the operation of a laboratory quality management system (refer joint ISO-ILAC-IAF communique dated 18 June 2005).

The described instrument has been checked and calibrated at **NORTHLAB SEAMS (M) SDN BHD** under the ambient conditions stated above.

METHOD OF CALIBRATION

- The instrument was calibrated as per method no. Procedure-017 in NLQM/001/10 of the Quality Manual and with reference to Digimatic Indicators and Linear Gauges as a guide.

<u>Standard instrument used</u>	<u>Serial No.</u>	<u>Traceability</u>	<u>Via Cal.Cert.No</u>	<u>Due date</u>
1. Gauge Block Set	0800165	NPL(UK)	ML/2013/0408	11-Jun-15

RESULTS OF CALIBRATION

- The results of calibration are given on the attached calibration data sheet(s).

REMARKS

- The user should decide on the usability of this instrument.
- *Recalibration date specified by client.
- The user should be aware that any number of factors may cause this instrument to drift out of calibration before the specified calibration interval has expired.

Calibrated by

Approved Signatory

HAYATI BT SEMAN

AZHAR BIN SALMAN

CALIBRATION CERTIFICATE

Cert No. : **KD/15/0427-3**

Job No. : **KCW099115**

Date of Issue : **28-Apr-15**

Page : **2 of 2**

RESULTS OF CALIBRATION

<i>FEATURE INSPECTED : ACCURACY</i>	
<i>NOMINAL VALUE (mm)</i>	<i>MEASURED VALUE (mm)</i>
0	0.000
5	5.002
10	10.000
15	15.000
20	20.000
25	25.002
30	30.000
35	35.000
40	40.000
45	45.000
50	50.000
<i>REPEATABILITY</i>	
<i>0.002 mm</i>	

- The expanded measurement uncertainty associated with the results is ± 0.001 mm estimated at a level of confidence of approximately 95% with a coverage factor of $k = 2$.

Calibrated by

Approved Signatory

HAYATI BT SEMAN

AZHAR BIN SALMAN

CALIBRATION CERTIFICATE

Cert. No. : KD/15/0427-7	Job No. : KCW099115
Date of Issue : 28-Apr-15	Page : 1 of 2

Customer : YJACK TECHNOLOGY SDN BHD
LEVEL 16, 1 SENTRAL, KL SENTRAL,
50470 KUALA LUMPUR, MALAYSIA

Date Received : 24-Apr-15
Date Calibrated : 28-Apr-15
Calibration Due Date* : 28-Apr-16
Ambient Temperature : 20 ± 1°C
Relative Humidity : 55 ± 5% r.h.

Instrument : DIAL GAUGE

Serial No. : TGG 778

Manufacturer : MITUTOYO

Tag No. : ---

Model No. : 3058S-19

Cal Range : 0 ~ 50 mm

Resolution : 0.01 mm

This laboratory is accredited in accordance with recognized international standard ISO/IEC 17025:2005. This accreditation demonstrates technical competence for a defined scope and the operation of a laboratory quality management system (refer joint ISO-ILAC-IAF communique dated 18 June 2005).

The described instrument has been checked and calibrated at **NORTHLAB SEAMS (M) SDN BHD** under the ambient conditions stated above.

METHOD OF CALIBRATION

- The instrument was calibrated as per method no. Procedure-017 in NLQM/001/10 of the Quality Manual and with reference to Digimatic Indicators and Linear Gauges as a guide.

<u>Standard instrument used</u>	<u>Serial No.</u>	<u>Traceability</u>	<u>Via Cal.Cert.No</u>	<u>Due date</u>
1. Gauge Block Set	0800165	NPL(UK)	ML/2013/0408	11-Jun-15

RESULTS OF CALIBRATION

- The results of calibration are given on the attached calibration data sheet(s).

REMARKS

- The user should decide on the usability of this instrument.
- *Recalibration date specified by client.
- The user should be aware that any number of factors may cause this instrument to drift out of calibration before the specified calibration interval has expired.

Calibrated by

Approved Signatory

HAYATI B. SEMAN

AZHAR BIN SALMAN

CALIBRATION CERTIFICATE

Cert No. : KD/15/0427-7

Job No. : KCW099115

Date of Issue : 28-Apr-15

Page : 2 of 2

RESULTS OF CALIBRATION

<i>FEATURE INSPECTED : ACCURACY</i>	
<i>NOMINAL VALUE (mm)</i>	<i>MEASURED VALUE (mm)</i>
0	0.000
5	4.998
10	10.000
15	15.000
20	20.000
25	25.000
30	30.000
35	35.000
40	40.000
45	44.998
50	49.998
<i>REPEATABILITY</i>	<i>0.002 mm</i>

- The expanded measurement uncertainty associated with the results is ± 0.001 mm estimated at a level of confidence of approximately 95% with a coverage factor of $k = 2$.

Calibrated by

Approved Signatory

HAYATI BT SEMAN

AZHAR BIN SALMAN



CONSTRUCTION INDUSTRY DEVELOPMENT BOARD
Tingkat 10, Menara Dato' Onn,
Putra World Trade Centre (PWTC), No. 45,
Jalan Tun Ismail, 50480 Kuala Lumpur



CONSTRUCTION RESEARCH INSTITUTE OF MALAYSIA
Makmal Kerja Raya Maysia (MKRM),
CIDB Wilayah Persekutuan, 1st Floor, Block E, Lot 8,
Jalan Chan Sow Lin, 55200 Kuala Lumpur

ISBN 978-967-0997-11-7



9 789670 997117